

FM 5-480

**PORT
CONSTRUCTION
and
REPAIR**

DECEMBER 1990

HEADQUARTERS, DEPARTMENT OF THE ARMY

DISTRIBUTION RESTRICTION: Approved for public release; distribution is unlimited.

PORT CONSTRUCTION AND REPAIR

TABLE OF CONTENTS

	Page
PREFACE	vii
Purpose and Scope	vii
General Port Construction	vii
Cargo in Containers	vii
User Information	vii
CHAPTER 1. MISSIONS AND RESPONSIBILITIES	1-1
Section I. GENERAL	1-1
FM 100-10 Responsibilities	1-1
TASCOM Assistant Chief of Staff, Movements	1-1
Engineer Responsibilities	1-1
Transportation Responsibilities	1-2
Section II. WATERFRONT UTILITIES	1-2
Water	1-2
Electricity	1-2
Fire Protection	1-3
Bulk Petroleum	1-3
Section III. LOGISTICS-OVER-THE-SHORE (LOTS) OPERATIONS	1-4
General	1-4
Responsibilities	1-4

DISTRIBUTION RESTRICTION: Approved for public release; distribution is unlimited.

* This publication supersedes TM 5-360, 1 September 1964.

CHAPTER 2 HARBOR STUDIES AND SURVEYS 2-1

 Importance of Historical Information 2-1

 Engineering Design 2-1

 Responsibility for Hydrographic Surveys 2-1

 Hydrographic Survey Methods 2-1

 Methods of Sweeping to Locate Obstructions 2-3

 Methods of Bottom Investigation 2-3

 Tides and Tidal Currents 2-4

 Tidal Prism 2-5

 Waves 2-5

 Wave Energy and Action 2-6

CHAPTER 3 PORT PLANNING 3-1

 Factors Influencing Seaport Locations 3-1

 Planning Prior to Occupation 3-1

 Standards for Estimation 3-2

 Port-Capacity Factors 3-2

 Determination of Wharf Requirements 3-3

 Quay Systems 3-3

 Square-Pier System 3-5

 Offshore Marginal Wharf System 3-5

 Pier-and-Slip System 3-6

 Angled Pier-and-Slip System 3-7

 Finger-Pier System 3-7

 Accessory Structures 3-8

CHAPTER 4 CONSTRUCTION PLANNING AND ORGANIZATION 4-1

 Purpose 4-1

 Capabilities of Construction Forces 4-1

 Floating Plant and Special Equipment 4-2

 Class IV Supplies 4-3

 Availability of Local Materials 4-3

 Availability of Local Labor 4-3

 Construction Planning 4-4

 Phases of Reconstruction 4-5

 Clearing Underwater Mines and Obstructions 4-7

 Inspection of Damage and Deterioration 4-7

 Replacement and Maintenance 4-8

 Rehabilitation of Locks and Breakwaters 4-8

CHAPTER 5 BREAKWATERS, ANCHORAGES, AND MOORINGS 5-1

 Background 5-1

 Section I. BREAKWATERS 5-2

Section II. WAVE-RESISTANT WALLS	5-5
Bulkheads	5-5
Revetments	5-7
Groins	5-7
Jetties	5-10
Seawalls	5-11
Design Requirements for Shore Protection	5-13
Maintenance and Repair	5-13
 Section III. ANCHORAGE	 5-13
Two Types of Anchorage	5-13
Harbor Depth	5-14
Onshore Mooring Anchors	5-14
Rock-Fill Timber Cribs	5-15
 Section IV. LANDING RAMPS	 5-16
 CHAPTER 6 WHARF LOCATION AND LAYOUT	 6-1
 Section I. LOCATION	 6-1
Currents and Silting	6-1
Suitable Water Depths	6-1
Onshore Topography	6-2
Rail and Road Connections	6-2
Open and Covered Storage	6-2
Expansion Provisions	6-3
Civilian Labor	6-3
 Section II. LAYOUT	 6-3
Lengths, Widths, and Water Depths	6-3
Distance from Shore to Water of Adequate Depth	6-4
 Section III. METHODS OF LOCATION	 6-5
Bulkhead and Pierhead Limit Lines	6-5
Effects of Structures on Currents and Silting	6-6
Transparent Templates and Terrain Models	6-6
Work-hours, Materials, and Equipment	6-6
Scheduling of Construction and Expansion Phases	6-7
 Section IV. DIMENSIONS AND APPROACHES	 6-8
Minimum Lengths, Widths, and Aprons	6-8
Width of Slips	6-8
Width of Approaches to Offshore Wharves	6-9
Approach Flares to Marginal Wharves	6-9
Approaches to Single-Length, Break-Bulk Cargo Wharves	6-9
Approaches to Multiple-Length Wharves	6-9

CHAPTER 7	EARTH-FILL WHARF STRUCTURES	7-1
General		7-1
Moles and Breakwaters		7-1
Masonry Quay Walls		7-2
Sheet Pile Bulkhead		7-2
Earth Fill for Quays		7-4
Base and Surface for Quays		7-5
CHAPTER 8	PILE WHARVES	8-1
Section I. BEARING PILES		8-1
Purpose		8-1
Types		8-1
Sheet Piles		8-5
Marine Borers		8-7
Pile Capacity		8-10
Pile Bents		8-11
Section II. TIMBER PILE WHARVES		8-13
Advantages and Disadvantages		8-13
Standard Plans		8-13
Stringer Layouts for Approach Flares		8-14
Section III. STEEL AND CONCRETE PILE WHARVES		8-15
Military and Commercial Uses		8-15
Future Uses		8-16
Section IV. CONSTRUCTION OF PILE WHARVES		8-17
Straightening, Cutting, Capping, and Bracing Piles		8-17
Layout for Positioning Piles		8-20
Pile-Driving Procedures		8-21
Erection of Stringers and Deck for Steel Pile Wharves		8-23
Concrete Surface for Timber Decks		8-24
Concrete Pile Wharves with Reinforced Concrete Decks		8-26
Installation of Stringers and Deck for Timber Pile Wharves		8-27
Erection of Fender Systems		8-28
Installation and Bracing of Dock Hardware		8-30
Pile Clusters		8-31
CHAPTER 9	WHARF HARDWARE, FENDERS, AND DOLPHINS	9-1
Types and Uses of Wharf Hardware		9-1
Installation of Wharf Hardware		9-3
Fender Piles and Chocks		9-4
Pile Clusters and Corner Fenders		9-5
Floating Log Fenders (Camels)		9-7
Pile Mooring Dolphins		9-7

CHAPTER 10 FLOATING WHARVES 10-1

 Section I. ARMY EQUIPMENT (CURRENT TO&E) 10-1

 Aluminum Pneumatic Floating Bridge (M4T6) 10-1

 Pneumatic Floating Steel (Superstructure) Bridge (Class 60) 10-3

 Floating Bridge (M4) 10-3

 Section II. NAVY EQUIPMENT 10-5

 P-Series pontoons 10-5

 Uses for P-Series pontoons 10-7

CHAPTER 11 SELF-ELEVATING BARGE PIERS 11-1

 Section I. DELONG BARGES 11-1

 Background 11-1

 Types 11-1

 Site Selection for DeLong Barge Units 11-5

 Past Uses of DeLong Barges in Military Cargo Handling 11-7

 Limits of DeLong Barges Used in Container-Port Construction 11-8

 Section II. FENDERS FOR BARGE UNITS 11-8

 Purpose of Fendering 11-8

 Fender Design 11-8

 Forces from Winds and Currents 11-9

 Recommended Techniques for Fender Design 11-10

 Section III. SHORE CONNECTIONS 11-10

CHAPTER 12 EXPEDIENT CONSTRUCTION 12-1

 General 12-1

 Expedient Construction Equipment 12-1

 Expedient Piers or Causeways 12-1

 Expedient Repair Concepts for Pile Foundations 12-2

 Repair Concepts for Pile-Support Structures 12-5

 Trusses 12-8

 Bracing and Connecting Methods 12-8

 Expedient Repair Concepts for Pier and Wharf Decking 12-14

 Expedient Marine Railway Construction 12-18

 Marine Lifts 12-18

APPENDIX A EXPEDIENT CONSTRUCTION DETAILS A-1

APPENDIX B	DREDGING	B-1
	Purpose	B-1
	Types of Dredging	B-1
	Dredging Operations	B-1
	Dredging Resources	B-2
	Obtaining Dredging Support	B-2
APPENDIX C	DIVING	C-1
	Section I. GENERAL	C-1
	Purpose	C-1
	Engineer Diving Support Concepts	C-1
	Diving Support Request Procedures	C-3
	Communication Zone	C-4
	Section II. ENGINEER DIVING FORCE ORGANIZATION	C-4
	General	C-4
	Control and Support Diving Team	C-4
	Lightweight Diving Team	C-5
	Section III. DIVING MISSIONS	C-5
	Occupation Activities	C-6
	Port Construction	C-7
	Physical Security Operations	C-7
	Port Repair	C-7
	Graves Registration	C-8
	Section IV. CLEARANCE AND SALVAGE OPERATIONS	C-8
	General	C-8
	Clearance Operations	C-9
	Salvage Operations	C-9
	Section V. LOGISTICS	C-10
	General	C-10
	Combat Support	C-10
	Combat Service Support	C-10
	Equipment Support	C-11
	Section VI. LIMITATIONS	C-12
	Environmental	C-12
	Operational	C-12
GLOSSARY		Glossary-1
REFERENCES		References-1
INDEX		Index-1

P R E F A C E

PURPOSE AND SCOPE

This manual is a guide and basic reference for engineer units building and rehabilitating ship-unloading and cargo-handling facilities in the theaters of operations (TO). It includes port planning and layout and construction of fixed and floating wharves to support both conventional and container ships. It covers the special problems of expedient construction of ports and railways on wharves and piers. The information concerning facilities for handling and shipping cargo in containers represents current development. The manual covers many techniques still in the concept stage. The user is cautioned to get the latest information before proceeding with plans. The material applies to both nuclear and nonnuclear warfare; however, in nuclear warfare, port construction would be confined to small ports not offering strategic targets to the enemy.

GENERAL PORT CONSTRUCTION

Obtaining adequate ports early in any overseas operation is very important. Securing and using already existing ports is usually better than securing a site and building a new port by conventional methods. Old ports require less material, time, and personnel. Old ports often have towns nearby, as well as shore facilities such as warehouses, roads, railways, and petroleum, oil, and lubricants (POL) terminals. New ports lack all these facilities. Generally, new ports and temporary landing facilities serve only in the initial phase of an invasion and follow-up logistics-over-the-shore operations (LOTS). Since established ports are better, beach sites are abandoned as ports as soon as established ports are acquired or rehabilitated.

CARGO IN CONTAINERS

Current trends in commercial shipping indicate that 90 percent of all cargo arriving in future TO will arrive by container. This method of shipping requires dock and road surfaces capable of withstanding great loads. It also requires heavy-lift equipment capable of transferring the largest loaded container (40 feet, 67,200 pounds) from ships up to 1,000 feet long and 115 feet wide. Current Army facilities components system (AFCS) port designs must be changed to support such an operation.

USER INFORMATION

The proponent of this publication is US Army Engineer School. Send comments and recommendations on DA Form 2028 (Recommended Changes to Publications and Blank Forms) directly to--

Commandant
U.S. Army Engineer School
ATTN: ATSE-TD-PM-P
Fort Leonard Wood, Missouri 65473

Unless this publication states otherwise, masculine nouns or pronouns do not refer exclusively to men.

DISTRIBUTION RESTRICTION Approved for public release; distribution is unlimited

CHAPTER 1

MISSIONS AND RESPONSIBILITIES

Section I. General

FM 100-10 RESPONSIBILITIES

Building and operating a TO port is a large and vital undertaking with many divisions of responsibility between Navy and Army forces. Engineers at the theater headquarters and the Theater Army Support Command (TASCOM) make basic decisions concerning ports including location, capacity wharfage, and storage facilities. General responsibilities of the theater commander, theater Army commander, and TASCOM commander are stated in Field Manual (FM) 100-10.

TASCOM ASSISTANT CHIEF OF STAFF, MOVEMENTS

The TASCOM Assistant Chief of Staff, Movements (ACS,M) is responsible for port operations and liaison with the Navy, Coast Guard, and other military and authorized civilian agencies, from both the U.S. and allied countries. Army engineer responsibilities include minor salvage operations, such as clearing obstructions and debris from harbor entrances, and channel improvement. However, the Navy is responsible for large-scale salvaging operations. The ACS,M requests, advises, and makes recommendations concerning engineer operations.

Theater, theater Army, and TASCOM functions for construction of a specific port include--

- a. Study of intelligence reports and all available reconnaissance applicable to each port area.
- b. Tentative choice of ports or coastal areas to use as part of the overall strategic planning.
- c. Assignment of the port mission.
- d. Determination of port requirements.
- e. Tentative choice of the construction, engineer units, special equipment, and material required.

ENGINEER RESPONSIBILITIES

Engineer units are responsible for port construction and rehabilitation. They coordinate all work with naval units engaged in harbor work such as clearance and salvage or neutralization of mines or underwater obstacles in the harbor. Engineer units coordinate with transportation units to assist in establishing construction requirements, plan construction, and recommend priorities.

TRANSPORTATION RESPONSIBILITIES

Transportation units operate the port facilities and coordinate construction needs with engineer units. They also assist in planning construction and recommending priorities.

Section II. Waterfront Utilities

WATER

a. Responsibilities.

(1) Quartermaster units are responsible for supplying potable water in the TO.

(2) Engineer units are responsible for construction and maintenance of water distribution facilities in the TO. Engineers are also responsible for water reconnaissance, well drilling, and water point improvement.

b. Methods. Even though newer ships can provide fresh water from sea water, not all ships making port calls in the TO can provide this service. Engineers must supply potable and nonpotable fresh water for these ships. Methods include--

(1) Fresh-water jetties similar to fueling jetties, with dolphins for mooring.

(2) Barges to supply ships moored offshore.

(3) Water supply at wharves. Operation orders normally specify that fresh water be piped and stored at the first deep-water berth.

c. Quantities. Daily requirements may go as high as 200,000 gallons. The logistics office determines potable and nonpotable water requirements for ports, including fire protection.

ELECTRICITY

a. Responsibilities. Engineer units are responsible for the construction, operation, and maintenance of electrical power distribution systems.

b. Sources. The source of electrical power is part of the integrated base design. Local electrical distribution systems and power generation stations are rehabilitated and used where possible. This may require electrical conversion equipment. Where no systems are available, military generators and/or Army Facilities Components System (AFCS) designs will be used. Assistance is available from the Office of the Chief of Engineers (OCE) Power Detachments.

c. Uses.

(1) Wharves or piers. Normally, only lighting is required. Wiring is in conduit. Overhead poles and lines are kept to a minimum. The DeLong pier has its own power generation capability.

(2) Area lighting.

(3) Street/road lighting.

(4) Security/perimeter lighting.

(5) Billets, administration, maintenance, and mess facilities.

FIRE PROTECTION

a. When engineers rehabilitate or construct ports, they ensure that there is adequate fire-fighting and fire-protection equipment. Engineers require water mains, hydrants, and standpipes/hoses supplemented by water sumps, buckets, and various types of hand extinguishers.

b. Fire-fighting units. Five fire-fighting teams are authorized:

(1) Team FA, fire-fighting headquarters.

(2) Team FB, fire trucks.

(3) Team FC, water trucks.

(4) Team FD, brush fire trucks.

(5) Team FE, aviation fire crash/rescue.

c. These teams, or their components, will provide port fire protection.

BULK PETROLEUM

a. Engineer units are responsible for the design, construction, rehabilitation, and major maintenance of bulk petroleum facilities from the high water point/mark downstream.

b. Quartermaster units are responsible for the operation and routine maintenance of bulk petroleum facilities.

Section III. Logistics-Over-the-Shore (LOTS) Operations

GENERAL

The Army needs LOTS to support cargo delivery to the TO. Army engineer units support LOTS missions because ports may be unavailable for long periods of time due to such causes as damage from combat, vulnerability to enemy combat action, or extended repair/construction. LOTS terminals handle at least 40 percent of all cargo entering contingency theaters by surface means. Rapid establishment of viable LOTS terminals depends on engineer units for construction and maintenance.

RESPONSIBILITIES

a. Transportation units have overall responsibility for LOTS. Each LOTS terminal is under the direct control of a transportation/terminal battalion which is made up of two service companies and appropriate support units.

b. Engineer units give construction, repair, and maintenance support to LOTS. An engineer unit may expect to encounter the following missions in supporting LOTS:

- (1) Constructing semipermanent piers and causeways.
- (2) Clearing beach obstacles.
- (3) Preparing and stabilizing beaches.
- (4) Constructing access and exit routes from beaches.
- (5) Providing access to marshaling areas and adjoining LOTS sites.
- (6) Constructing marshaling and storage areas.
- (7) Constructing road and rail links to existing LOCs.
- (8) Constructing utility systems.
- (9) Constructing POL storage and distribution systems.
- (10) Providing other assistance or maintenance support assigned by the terminal commander.

CHAPTER 2

HARBOR STUDIES AND SURVEYS

IMPORTANCE OF HISTORICAL INFORMATION

Until recently, scientific design criteria for shore protection developed slowly. Long trial and error expedience led to structures best suited to local conditions. Engineers had to experiment to find a suitable protected site long enough for an inner harbor without the rapid shoaling of channel approaches. The history of early structures and construction methods is practical background for new construction.

ENGINEERING DESIGN

Wherever possible, standard designs can save time in design, construction, and maintenance. Standard designs and bills of material allow advance procurement of materials and equipment. Using them requires a knowledge of the site and the existing foundation. Reconnaissance, construction surveys, soil bearing tests, driving of test piles, and sieve analyses of local sands and gravels precede final design. Engineers design nonstandard expedient structures only when they cannot use standard designs.

RESPONSIBILITY FOR HYDROGRAPHIC SURVEYS

The mapping organization in the TO follows policies set by the G2. The theater engineer coordinates the work of the topographic units in carrying out policy. The theater engineer also coordinates the work of all topographic units of subordinate commands. The unit engineer plans and executes work needed by a particular unit that is not included in the theater mapping program. The engineer includes special maps and map overlays. His topographic units make astrofixes for map control and to tie into the existing triangulation system. Construction units establish azimuth and some vertical control for assigned construction jobs.

HYDROGRAPHIC SURVEY METHODS

Technical Manual (TM) 5-235 describes military equipment and methods of taking and locating soundings. Specific information includes--

a. Factors considered in hydrographic surveys. To locate a wharf site, the engineer must determine the submerged relief at the proposed site.

(1) Water depth. Water depth is critical to the operation of ships and craft. Engineers must obtain bathymetric measurements in the port area and seaward approaches to the facilities. The normal draft for a container ship is approximately 40 feet.

(2) Bottom character. Engineers must study the character of the bottom. They must locate and remove or mark foreign and random objects, including boulders, oil drums, and ship wreckage.

(3) Tidal characteristics. Tidal parameters that require determination are heights, range intervals, times, and behavior of tidal currents on a daily and seasonal basis and during storms. Daily tidal ranges exceed 20 feet.

(4) Discharge volumes and river flow velocity. These factors affect traffic regulation, structure location and orientation, sediment transport and deposition, and dredging.

(5) Extent, duration, and causes of inland flooding. Harbor routine may vary during flood seasons. Sediment introduced in harbor areas may create navigation problems. Historical data helps accurate forecasting.

(6) Tidal and river currents. Current direction and velocity affect navigation. There are longshore currents, wind currents, river currents, and permanent great currents. Several currents may act together.

(7) Shoreline data. Shore tidal conditions must be established for daily, seasonal, and extreme tide stages.

(8) Location of landmarks as navigational aids. Hydrographic and topographic maps and aerial photography simplify locating landmarks. Field checks ensure acceptable visibility.

(9) Location of current and abandoned structures in the water and along shore margins.

(10) Sub-bottom characteristics. These include sediments, layering, bearing capacities, and consolidation.

b. Types of surveys. To obtain the required information, engineers make the following separate surveys:

(1) Construction planning survey. Establishes basic facts of shoreline, water depth, bottom character, and existing structures.

(2) Special detail survey. Serves specific projects of construction or rehabilitation.

(3) Survey of operating harbors. Obtains data on channel characteristics, aids and hazards to navigation, wharf location, and harbor structures.

c. Methods of hydrographic survey.

(1) Contemporary. Methods depend on type of data required, equipment of the team making the survey, area to cover, and character of the body of water being surveyed.

(2) Sounding methods. Engineers make and plot soundings to ensure proposed wharf locations have adequate depth. TM 5-235 describes current Tables of Organization and Equipment (TOE) equipment for sounding operations. It includes automatic depth recorders, sounding poles (to 2 fathoms), leadlines (more than 2 fathoms), sweeps and drags, special survey vessels, buoy markers, signals (tripods, pylons) set up ashore, sextants, and others. Recording tide heights is a standard process, but soundings make recording easier. Depths measured and recorded below the water level are corrected on charts of the location.

METHODS OF SWEEPING TO LOCATE OBSTRUCTIONS

a. Sweeping locates pinnacles or other navigation obstacles above the draft limits required for the largest ships to use the area. Sweeping is always used as a final check after dredging. Sweeping is discussed in TM 5-235.

b. Methods of sweeping.

(1) Leadlines. Leadlines indicate the depth in waterways with regular bottoms. They cannot reliably show minimum depth over rock pinnacles, sunken wrecks, or other dangers.

(2) Wire drag. The wire drag is a horizontal bottom-wire. It is supported by adjustable upright cables suspended from surface buoys. The upright cables can be adjusted to sweep at a given depth. They make adjustments for the rise and fall of the tide. They hang nearly vertical with weights at their lower end. The drag wire is kept from sagging by several intermediate wooden floats attached to the wire. The drag wire, which may be 5 miles long, is towed by two launches. A buoy is placed over each obstruction located, then the drag is cleared. A small sounding boat makes careful soundings in the buoyed area to find the minimum depth over the obstruction.

(3) Wire sweep. The wire sweep is a modification of the wire drag. Buoys are placed farther apart. The wire sweep cannot vary the depth of the wire while dragging. It cannot prevent sag of the wire between buoys. It can be put in operation quicker than the drag. It is used in areas with few obstructions and with water deeper than required for navigation.

(4) Sweep bar. Surveyors use sweep bars to determine minimum clear depths. They locate obstructions and navigation dangers in confined areas, such as shoals, rock pinnacles, reefs, or wrecks. The sweep bar is a heavy section of railroad rail, steel pipe, or a structural steel section. It is held by two vertical cables. It can be suspended from a float, catamaran, or boat of suitable size. The suspending craft may be either towed or self-propelled. It must maneuver to maintain horizontal sweeping control. The sweep bar is suspended to avoid sag or deflection. The supporting craft can control depth by adjusting the cables holding the bar. Sweep bars have wide applications. They range from small hand sweeps operated from a rowboat for locating minor obstructions to specially-designed crafts for sweeping large channels and harbors.

(5) Specialized sweeping. Naval units are required when sweeping for mines.

METHODS OF BOTTOM INVESTIGATION

a. Types and uses.

(1) Underwater investigations of bottom materials are made from wash borings, core borings, probing, and diving.

(2) A hydrographic survey includes superficial bottom examination based on materials that adhere to grease kept in a cup-shaped depression in the bottom of the sounding lead.

(3) Investigations of bottom materials are made to--

- * Indicate the probable length and size of adequate bearing
- * Establish the most suitable pile material.
- * Determine the type and depth of dredging or type of dredging equipment to use.

b. Wash borings.

(1) The bottom material must be soft enough so a casing pipe can penetrate it. The casing is driven into the bottom, a few feet at a time. A hollow drill rod is inserted in the casing. The nozzle at the lower end of the drill rod usually has a chisel point for boring. Water is washed down the rod as it is raised and lowered in the casing. Water and bottom material are forced to the surface between the casing and the rod. This overflow is discharged into a bucket. Suspended material is allowed to settle for analysis.

(2) To obtain a dry sample, the drill is removed. In its place, a short length of sample pipe is attached to the rod. The rod is placed in the casing and driven a foot or more into the bottom to force a sample of material into the sample pipe. The casing stands in place until the rod and sample pipe are removed with the dry sample.

c. Core borings. Core drilling is necessary for rock stratum and for soils containing clay or clay with boulders. A casing is driven through the overlying soil to its limit of penetration. Materials within the casing are then removed. Rotary-drill coring equipment is then inserted into the casing to remove the core.

d. Probing. Probing serves mainly to determine the depth to the surface of rock or hardpan. It obtains bottom materials and tests bottom hardness. Lengths of pipe are forced into soft bottom materials by hand or are driven with a maul.

e. Diving. Usually divers investigate underwater piling and other foundations or obstructions.

TIDES AND TIDAL CURRENTS

Tides have a variety of effects on port construction (see TM 5-235). Tidal currents are the alternating horizontal movements of water associated with the rise and fall of the tide. They are caused by astronomical forces.

a. Information. The Naval Oceanographic Office, Washington, D. C., maintains files of hydrographic charts for areas throughout the world, exclusive of the U.S. The office also prepares tide tables and other hydrographic data, which are available upon request. Lists and publications include sailing directions, lists of lights, radio weather and navigational aids, current atlases, fleet guides, marine geographies, surface temperature charts, tide tables, tidal current tables, general navigation charts, and coastal hydrographic charts. Information about the coastal waters of the U.S. and its possessions is published in detail by the National Ocean Survey (formerly Coast and Geodetic Survey), U.S. Department of Commerce. Winds or river discharge may cause currents to vary from predictions by as much as half an hour in well-documented areas. In poorly documented areas, variation may be greater.

b. Effects of tidal waves by type.

(1) Progressive. A progressive wave leads to maximum current flow near high and low tides. The rate of progress of the rest of the tidal wave is much greater than the speed of the current. For example, the crest of the tidal wave in the Hudson River advances at a rate of about 16 knots; however, the average maximum rate of the tidal current is less than 2 knots.

(2) Stationary. Oscillation of the water in the basin leads to maximum current flow at half tide. Strength of current is greatest at the axis of oscillation. It decreases as it approaches the end of the basin, where the range of the tide is greatest.

TIDAL PRISM

The tidal prism is the total amount of water flowing into a harbor or estuary or out again with movement of the tide. It excludes any freshwater flow. The tidal prism may be estimated by measuring the volume of the area or the volume of flow through the harbor entrances. Changes in the tidal prism and restrictions of the waterways may change the depth or direction of existing channels. These changes happen through scour or sedimentation. Such changes are difficult to predict or evaluate. Constructing pile structures, where practical, can avoid changes in the tidal prism.

WAVES

The familiar ocean waves are wind waves generated by winds blowing over water. They range in size from ripples on small bodies of water to large ocean waves as high as 100 feet. Wind waves cause most of the damage to ocean coasts. At sea or near the shore, the most noticeable waves are often swell associated with winds over great distance. Another type of wave, the tsunami, is created by earthquakes or other tectonic disturbances on the ocean floor. Tsunamis have caused spectacular damage at times. Fortunately, tsunamis occur infrequently.

a. Wave characteristics. Wind waves are known as oscillatory waves. They are defined by height, length, and period.

(1) Definition of wave terms. Wave height is the vertical distance from the top of the crest to the bottom of the trough. Wave length is the horizontal distance between successive crests. Wave period is the time between successive crests passing a given point.

(2) Determination of wave characteristics. Four variables determine the height, length, and period of wind waves--

- * Fetch, or the distance the wind blows over the sea in generating the waves.
- * Wind speed.
- * Length of time the wind blows.
- * Decay distance, or distance the wave travels after leaving the generating area.

Generally, the longer the fetch, the stronger the wind. The longer the wind blows, the larger the waves. If shallow enough, the water depth affects the size of wave generated.

b. Wave classifications. A description of a wave involves both its surface form and the fluid motion beneath it. A wave describable in simple mathematical terms is called a simple wave. Complex waves have several components and are difficult to describe in form and motion. Other classifications include oscillatory or nearly oscillatory waves. In these, water particle motion is described by orbits which are closed or nearly closed for each wave period. The type of wave most important to port construction and rehabilitation is the gravity wave. Gravity is the principal restoring force. Gravity waves are further classified as deep water, transitional, or shallow-water waves.

c. Deep-water waves. Deep-water waves are at a water depth more than one-half the wave length or when d/L (Figure 2-1) exceeds one-half. The phase velocity is the length of the wave divided by the time required to travel this length. It is an important characteristic of wave motion.

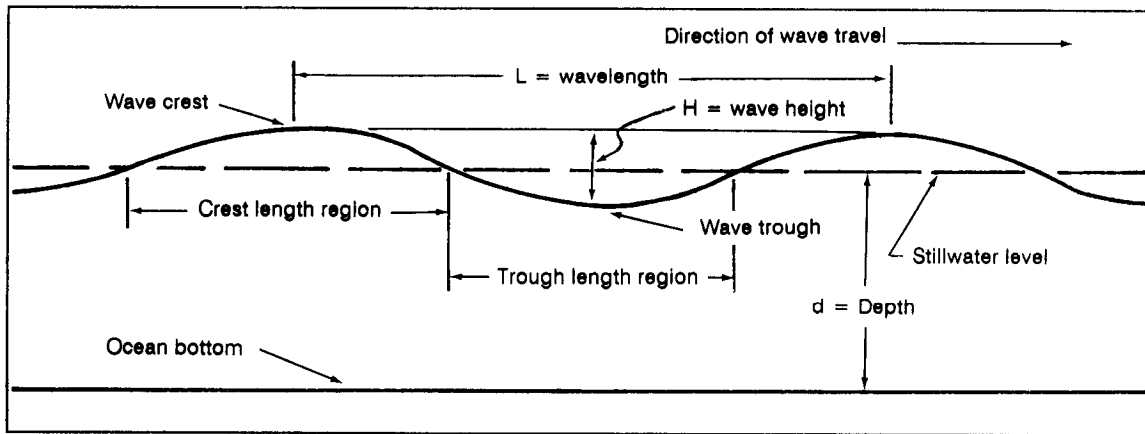

Figure 2-1. Deep-Water Wave

WAVE ENERGY AND ACTION

a. Energy content of waves. The total energy of a wave system is the sum of its kinetic energy and its potential energy. The kinetic energy is that part of the total energy due to water particle velocities associated with wave motion. Potential energy is the energy resulting from the part of the fluid mass above the trough. According to the Airy (first-order) theory, potential energy may be determined relative to mean water level. All waves may be propagated in the same direction. Potential and kinetic energy components may be equal. Under these conditions, the total wave energy (E) is one wave length per unit crest width, as given by Equation 1.

$$E = E_k + E_p = \frac{\rho g H^2 L}{16} + \frac{\rho g H^2 L}{16} = \frac{\rho g H L}{8} \quad (\text{Equation 1})$$

where:

E_k = kinetic energy

E_p = potential energy

ρ = mass density = w/g (w = unit weight) = $\frac{2.0 \text{ lb-sec}^2}{4\text{ft}}$ (slugs/ft³) for salt water

g = gravitational acceleration

H = wave height

L = wave length

Substituting $p = 2.0$ slugs/ft³, the equation can be reduced to a proximately $E = 8LH^2$. This equation indicates a wave 12 feet high and 1,300 feet long with an energy content of nearly 1,500,000 foot-pounds per foot of wave length. Dynamometer readings on breakwaters exposed to the direct force of waves show wave pressures as high as 7,000 pounds per square foot. These are maximum readings over an area of about 1 square foot. It is improbable that equally great pressures are experienced over the total area of a bulkhead or break water.

b. Forces exerted by a blocked wave. When a wave is suddenly stopped by an obstacle, it generates the following forces, which act alone and together on the obstacle:

(1) Direct horizontal force combining impact and continued pressure. A breakwater with a constant water level on the sheltered side feels pressure on the exposed side. One end of fluctuation is the result of a positive combined pressure from the kinetic energy of the moving water and the static head of the wave at maximum height. The other end is a negative pressure when the trough of the wave is at the breakwater.

(2) Deflected vertical force upward.

(3) Vertical downward force resulting from the collapse of the wave.

(4) Downward kinetic and static pressure on top of the structure.

(5) Suction from the backwash, which tends to produce negative pressure inside the structure

c. Height of rise of a blocked wave. The energy content of a wave is equally divided. One part is the kinetic energy of the moving particles of water. The other is the potential energy of the mass of water raised above still water level. A wave may encounter a vertical obstruction in water greater than its breaker depth. The kinetic energy of the moving particles is then largely converted to potential energy. The wave rises to nearly twice its normal height. This fact is important in the design of structures in water with a depth greater than breaker depth because it permits calculating the maximum height needed to keep waves from breaking over the top.

d. Effect of wave action on a structure. Waves have many effects on natural and man-made coastal features. The tremendous wave forces generated by a storm make damage likely. The forces exerted by a blocked wave may cause the following effects on obstacles:

(1) Vibration or weaving, which tends to weaken connections.

(2) Hydrostatic pressure or suction in all directions in the joints and interstices.

(3) Alternate compression and expansion of volumes of air in cavities, which transmit pressure to internal parts.

(4) Deflected vertical force, which tends to shear off projections beyond the face line of a structure.

(5) Direct horizontal force of impact and continued pressure, which tends to overturn or slide.

e. Battering -ram action of floating objects. The energy of a wave is contracted as a battering ram when it hurls a floating object.

CHAPTER 3 PORT PLANNING

Successful port construction requires careful planning based on detailed reconnaissance. Reconnaissance continues until actual occupation. Planning may appear complete before occupation, but last-minute enemy action may necessitate a major change in plans.

FACTORS INFLUENCING SEAPORT LOCATIONS

A seaport should lie near sheltered waters. Shelter comes in any of the following ways:

- a. A bay or river forms a natural location for a seaport.
- b. Engineers create shelter by increasing the length or height of natural formations, such as land arms, rocks, reefs, islands, or other barriers.
- c. Engineers build breakwaters or jetties as protection for the inner water.

PLANNING PRIOR TO OCCUPATION

a. Before occupying a port, planners must consider estimated logistical requirements and both the current and expected physical condition of the port to be occupied. Planning prior to occupation covers a long period of time. Operation orders then give construction assignments, facilities required, and target dates for development.

b. The theater commander must evaluate ports according to the possible quantity and nature of cargo and personnel they will handle. Often this phase of planning depends on the first reconnaissance. The commander examines previous plans critically in view of the physical condition of the port. Priorities in the operations order may change in light of the port's actual physical condition. The commander coordinates indicated changes and their impact on logistics through Army engineer, transportation, and other command channels, as well as with naval units engaged in clearance, dredging, and other harbor projects. Planning and scheduling depend on meeting all immediate needs and making all work contribute toward meeting final requirements.

c. During final development, planning depends on a full knowledge of the theater-wide logistical situation. Planners study the relative value of rehabilitation and construction, and the value of specific facilities to the construction effort required. Selection of the best sites for development depends on need for dispersion, location of logistical requirements, time and effort needed to move construction units, locally available material, and civilian or prisoner-of-war labor. Similar factors determine the best development within a port.

STANDARDS FOR ESTIMATION

The following terms establish standards for estimation:

a. **Port capacity.** The estimated amount of dry cargo, containerized cargo, and bulk and roll-off equipment. It is usually expressed in weight, measurement tons, or number of containers per day that can be discharged onto the available piers, wharves, quays, jetties, moles, and beaches of a port.

b. **Standard minimum width.** The wharf width for deep-draft noncontainerized ships using one-side discharge is 60 feet, or 90 feet for two-side discharge. Container ships require 80 feet, and lighterages either 35 or 42 feet.

c. **Minimum required depth below mean low water.** The depth required by the draft of a ship. For deep-draft noncontainer ships, the minimum required depth is 30 feet. For high-speed container ships, it is 40 feet. Shallow-draft crafts require a minimum of 12 feet.

d. **Wharf systems.** Wharves include any extensions built from shore to water of minimum required depth to provide direct contact for handling cargo between deep- or shallow-draft ships and shore. "Wharves" also include structures described as quays, piers, or marginal wharves.

PORT-CAPACITY FACTORS

a. **Engineer responsibility.** Port-capacity requirements are estimated by Headquarters, Transportation Command (TRANSCOM) or by the TASCOM ACS,M. The construction engineer usually makes an independent estimate of the capacity of the port under various alternative methods of construction, repair, or rehabilitation. This estimate is used to determine priorities for engineer projects. The person doing this estimate must understand how the capacity estimates of TRANSCOM and TASCOM work with respect to military loads. The engineer recommends schedules for repair and maintenance of port cranes and other equipment and facilities, roads and railways within the port area, and storage and marshaling areas.

b. **Wharf facilities.** Rehabilitation, construction materials, and plans affect wharf capacity.

c. **Discharge rates.** Port capacity estimates depend on the discharge rates of ships either at the wharf or in the stream. Priority goes to expedient methods that allow ships to discharge quickly. Construction coordinated with transportation units cuts interference with the discharge of ships.

d. **Anchorage available.** Sheltered anchorage allows for discharging cargo while deep-water wharves are constructed or repaired. Continuous lighter craft usage allows the following:

(1) Continuous dredging of the deep-water approach channel using the shallow-draft approach with discharge outside the dredging areas.

(2) Use of the shallow-draft parts of wharves while some of the deep-water wharves are under construction.

(3) Unloading the shallow-draft vessels over deep-draft wharves when removing obstructions that prevent deep-draft use.

e. Other factors. Base periods of time, such as the 2-shift, 20-hour working day or a specified number of days in a month, allow engineers to consider bad physical conditions peculiar to the location in preparing time estimates. For example, they can estimate time needed in some harbors to work in ice during winter. Extreme range of spring tides may bear upon work. Where heavy seasonal rains, snowfall, icing, severe winds, fog, and heat or cold exist along a coastline, engineers modify their estimates to allow for these conditions.

DETERMINATION OF WHARF REQUIREMENTS

Standard wharfage requirement estimates match only the specifications for noncontainer ships, but only an 80- by 900-foot wharf is sufficient to support the latest container vessels. Total estimated container wharfage is the basis for up-to-date wharf layout. To compare density where shore front is limited, use Table 3-1 and Figure 3-1, page 3-4.

TABLE 3-1. Linear Feet of Berthing Spaces per 1,000 Feet of Shore Front

Type of layout	Freighter	Lighter	Total
(1) Quay	1,000		1,000
(2) Square pier	2,143		2,143
(3) Right-angle pier for one freighter on each side	3,120	313	3,433
(4) Right-angle pier for one freighter plus one lighter on each side	3,120	1,250	4,370
(5) Acute-angle pier for one freighter on each side	2,690	270	2,960
(6) Right-angle pier for two freighters on each side	4,160	208	4,368
(7) Acute-angle pier for two freighters on each side	3,600	180	3,780
(8) T-type marginal wharf for freighter on outside face and lighters on inside face	770	*1,380	*2,150
(9) U-type marginal wharf	1,000 or less		1,000 or less
(10) Finger pier	3,120	**313	**3,433

Note. These figures are for purposes of comparison only.
 * 1,682 feet and 2,452 feet if traffic conditions are such that lighters can be worked along the faces of the causeway.
 ** Up to 813 feet and 3,933 feet if traffic conditions are such that lighters can be worked along the faces of the causeway.

QUAY SYSTEMS

a. Characteristics. A quay (Figure 3-1,(1)) is a marginal wharf supported by either the shore itself or by solid fill. Quays are used in water with minimum required depths. A piled marginal quay is supported by shore bracing and piling. The linear feet at the face of the quay is the length of berth accommodations.

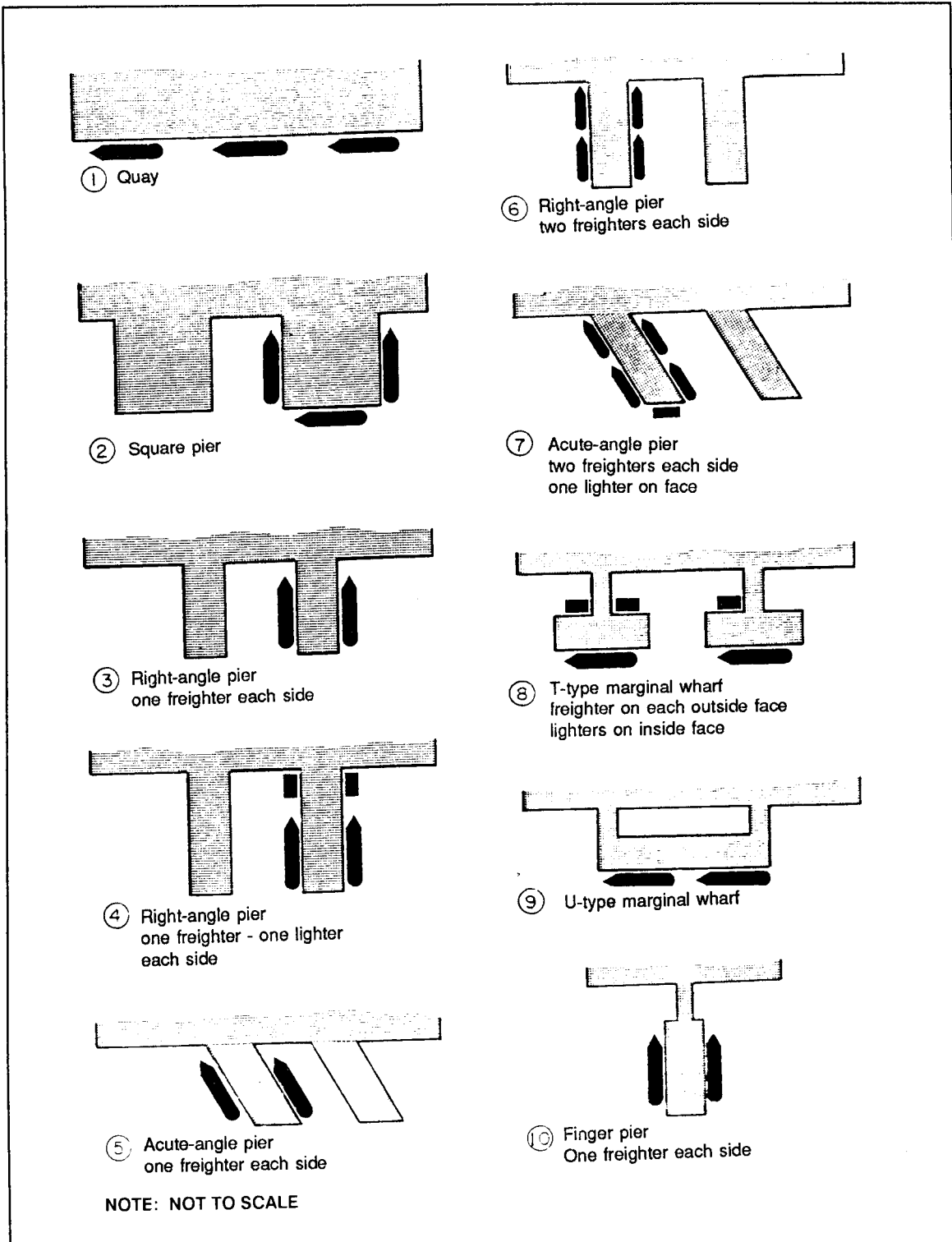

Figure 3-1. Wharf Layout

b. Advantages.

(1) Stability and bearing strength of the solid fill supports the load, especially when handling cargo in containers.

(2) Accessibility of the upshore work area.

(3) Use of surplus fill.

c. Disadvantages.

(1) Moving earth or other material to provide fill requires equipment and personnel.

(2) Berth length is limited to the length of the wharf face, unless mooring dolphins extend the usable length.

SQUARE-PIER SYSTEM

a. Characteristics. A square pier (see Figure 3-1, (2)) has berth accommodations at the sides as well as at the face. It is supported by solid fill or piling. Usually the area of the deck is so great that it precludes all-pile construction. For this reason, this type of pier is rarely adaptable for new construction. For linear feet of berthing space per 1,000 feet of shore front, see Table 3-1.

b. Advantages.

(1) Solid fill offers stability and bearing strength.

(2) Upshore areas are accessible for storage and traffic circulation.

(3) Side berths add to berthing accommodations.

c. Disadvantages.

(1) Moving earth for fill requires equipment and personnel.

(2) Requirements for fill or piling are great compared to usable space on the deck.

(3) When on fill, the square pier changes the natural current system.

OFFSHORE MARGINAL WHARF SYSTEM

a. Characteristics. An offshore marginal wharf (Figure 3-1, 8 and 9) is located offshore but parallel to the shoreline. Causeways are used to connect the wharf to the shore. The wharf provides deep-water berths at its outer face. Shallow-water berths often lie along the causeway section and shoreward face. The wharf is either floated or supported by piles or solid fill. Causeways are solid construction resting on piles or floating. U-type causeway and wharf arrangements allow truck traffic to circulate.

b. Advantages.

(1) The layout allows many construction methods. Navy pontoon gear normally supplies needed floating wharfage.

(2) Moorings for shallow-draft craft range along the sides of the causeway. When multiple causeways are used, a movable section can provide access to space(s) between causeways for mooring or unloading vessels of suitable draft.

(3) Along rocky shores, offshore construction is likely to save costs.

c. Disadvantages.

(1) If only a single causeway is available, unloading or traffic problems may occur.

(2) The large area of the wharf structure not tied to shore anchorages requires moorings that are not supported by the wharf structure.

PIER-AND-SLIP SYSTEM

a. Characteristics. The pier-and-slip system (Figure 3-1, (3), (4), and (6)) provides alongside-berthing space perpendicular to the shore. Commercial ports generally use this system. The piers are long enough to accommodate the ships and wide enough to provide adequate working space for cargo handling. The slip should provide depth for the ships and width between two berthed ships at adjacent piers for floating cranes and other harbor craft and equipment. Piers are usually built on piles, but may have solid-fill mass support. Pier construction is obviously impractical in water that is too deep for the available piling. If water depths cause large unsupported piling lengths, dump rock fill after the piles are driven.

b. Advantages.

(1) Offers more linear feet of berthing for a given length of shoreline.

(2) Pier work space is directly accessible from the shore area.

c. Disadvantages.

(1) Limited space between piers causes dense navigational traffic in and around the piers.

(2) Piers are an encroachment on the restricted waterway.

(3) Pier- or bulkhead-limit may affect the line set to ensure adequate channels or anchorage.

ANGLED PIER-AND-SLIP SYSTEM

a. Characteristics. The angled pier-and-slip system (Figure 3-1, (5) and (7)) provides alongside berthing, but the piers are not placed at right angles to the shore. This type of system is frequently used where strong currents or strong prevailing winds would adversely affect perpendicular piers.

b. Advantages. This layout fits narrow shorelines where the perpendicular-pier layout cannot be used or where the pier system is located on a narrow waterway, with insufficient room for a ship to make a 90-degree turn to enter the slip.

c. Disadvantages.

(1) With normal current and wind conditions and adequate approaches, ships berth and moor more readily in slips with a 90-degree layout.

(2) Construction is difficult and requires more material.

(3) Abnormal currents or winds make the use of tugs critical.

FINGER-PIER SYSTEM

a. Characteristics. The finger-pier (Figure 3-1, (10)), like the pier-and-slip system, provides alongside berthing space. If built wide enough, finger-piers can accommodate vessels on each side. A simple causeway of pile construction or solid fill, or a floating causeway is used to connect the pier to the shore.

b. Advantages.

(1) Adaptable to many types of construction. It may be built using piles, floating wharfage, or the steel-spud or spud-type barge.

(2) Shallow-draft craft can discharge onto the causeway.

(3) Pier can serve in marshes and mud flats.

(4) Where tides fluctuate, the finger-pier causeway can extend out into deeper water to ensure an adequate depth, regardless of the tide.

c. Disadvantages.

(1) The single causeway may result in unloading and traffic problems.

(2) Separate moorings, which are not supported by the wharf structure, may be required for mooring ships at the wharf.

ACCESSORY STRUCTURES

a. Lighter wharves and basins. Lighters are shallow-draft craft used for loading or unloading larger vessels. They may be either self-propelled or towed. The controlling depth for lighter crafts is the same as that of the tugs which use them, usually 12 feet. However, at lighter wharves, extremely shallow water or breaching on the soft bottom is possible. Self-propelled lighters, especially those with outboard engines, need more depth than their actual draft to prevent fouling of their cooling systems while navigating over the soft bottoms. Required slip width is based on the beam of the craft and navigational requirements.

b. Floating wharves.

(1) Characteristics. Floating wharves, typically fabricated from Navy pontoon gear, can be assembled in almost any size layout. Use hinged joints to avoid long, rigid structures. A typical floating wharf for a single noncontainer cargo ship has a 43- by 431-foot deck with two or more pontoon bridge approaches. Existing designs and equipment specifications will require modification and strengthening to support container operations.

(2) Advantages.

* Floating wharves can be moored in water that is too deep for pile driving. They are good in areas with very high (30 feet or more) tides.

* Pontoon cube bridges or sections can be assembled elsewhere and towed into place, reducing in-port assembly time.

* These wharves permit quick assembly, movement, and disassembly. Piecemeal disassembly during replacement by a fixed wharf is also possible.

(3) Disadvantages.

* Initially light maintenance requirements may later become heavy because of weakened connections and corrosive effects of salt water.

* Equipment will not support the large deck loads of containers.

* Operations using floating wharves must stop during high seas.

c. Jetties, breakwaters, and moles. Jetties and breakwaters are usually designed and located primarily to protect the harbor and its channels. When favorably located and furnished with a vertical face on the protected side, both structures may serve as tie-ups for ships and, when surfaced, as wharves. When used this way, a breakwater is called a mole.

d. Bulk petroleum handling facilities. Facilities consist of wharves, dolphin moorings, ship-to-shore pipelines, and shore pumping stations and storage tanks. For fire protection, these facilities must be a safe distance from other structures and storage areas. Terrain barriers, ground slopes, and current charts are used to keep gasoline from flowing overland or floating on water. If the port is small and congested, an outside location at a protected cove or roadstead is preferable. Coordination with the Quartermaster Corps, Transportation Corps, and Navy helps in selecting locations.

e. Marine railways and graving docks. Engineers allocate space not needed for wharfage, navigation, or onshore facilities to provide for marine railways. They allow space for the marine railway from the piling that marks the deep-water end of the railway to the winch, or other equipment, handling the cable on shore.

(1) A marine railway consists of a platform with a cradle. It operates on a railway from deep water to shallow water or dry land. Small vessels are secured to the cradle on the platform and hauled ashore.

(2) A graving dock is a basin into which a vessel is floated. The basin is then emptied to do work on the underwater part of the hull. After completion of the work, the basin is flooded and the vessel floats back into service.

CHAPTER 4

CONSTRUCTION PLANNING AND ORGANIZATION

PURPOSE

a. Careful construction planning cuts costs and creates an orderly sequence for the project.

b. Construction planning enables the manager to--

- (1) Determine the tasks.
- (2) Establish priorities.
- (3) Determine time schedules for each task and for the entire project.
- (4) Identify personnel and equipment needs.
- (5) Forecast requirements for materials and special equipment to prevent delays.
- (6) Establish responsibility.

c. Effective port construction planning requires--

- (1) Reconnaissance and study of the proposed port site.
- (2) Estimates of material, equipment, and personnel.
- (3) Consideration of nonorganic equipment.
- (4) Preparation of construction time schedules.
- (5) Knowledge of unloading capacities.

CAPABILITIES OF CONSTRUCTION FORCES

The engineer unit responsible for major port construction or rehabilitation is the engineer construction group. It includes an engineer port construction company or companies, pipeline construction and support companies, engineer combat (heavy) battalions, dump truck companies, engineer construction support companies, dredge teams, and other units the mission may require. When several groups work together, they are organized as an engineer brigade with various capabilities.

a. The headquarters and headquarters company in an engineer construction brigade supervises a force of two to four engineer construction groups and supporting troops--5,800 to 15,000 soldiers.

b. When organized for port construction, an engineer construction brigade can plan and carry out any port construction or rehabilitation project in military operations.

c. The engineer construction group is a flexible organization. It becomes operational only when working units are assigned or attached to it. The headquarters and headquarters company in an engineer construction group command supervises three to five engineer combat (heavy) battalions or their equivalent in assigned or attached troops. Two or three combat (heavy) battalions and at least one port construction company help organize the group for typical wharf construction. Pipeline construction support companies, dredge teams, construction support companies, and dump truck companies are added as required.

d. The engineer combat (heavy) battalion is the basic unit assigned to a specific project or to separate minor projects. When working on port construction projects, the battalion can draw on several sources. It can have a port construction company, pipeline construction support company, dump truck company, construction support company, and dredge team.

e. The engineer port construction company operates as one element of a large-scale, coordinated construction operation under an engineer group. It can serve separately on minor projects at separate locations. Its main activities are construction or major repair of waterfront structures and POL off-loading facilities and anchorages. It is better to assign related on-land sub-projects to a construction battalion or other specialized unit. The port construction company should handle specialized waterfront construction. It is organized for two-shift operation. Its equipment includes crane-shovels with attachments for dredging, excavating, pile driving, and other work; pipeline equipment; hydraulic jacks; air compressors; pumps; tractors; concrete mixers; barge assembly sets; diesel-powered outboard propelling units; bridge erection boats; and landing crafts, mechanized (LCMs).

f. The pipeline construction support company provides technical skills and special equipment to assist engineer units. It can work separately on minor projects. It is normally attached to a construction group on the basis of one per construction battalion.

g. The engineer dump truck company augments the earthwork capabilities of other units. It operates 48 dump trucks on a two-shift basis. The trucks are loaded by the supported unit.

h. The engineer construction support company is assigned to an engineer group to provide equipment and operators for large-scale earthmoving, quarrying, or surfacing work.

i. Engineer dredge teams of TOE 5-500 (Series) are assigned to operate organic cutter-head pipeline or seagoing hopper dredges. Other types of dredges are best operated by local personnel.

j. Other units required for engineer service may include forestry, topographic, intelligence, maintenance, fire-fighting, and utility units.

FLOATING PLANT AND SPECIAL EQUIPMENT

Floating plant items used in the construction, rehabilitation, and operation of a harbor include--

a. Lighters, barges, and rafts. These include lighters and barges for general cargo, fuel oil barges, fresh-water barges, and rafts to haul piles and do general work on offshore structures. They may be towed or self-propelled. Their simple design and shallow draft allow them to perform well in construction work. Barges and lighters are made self-propelled by installing 165 horsepower outboard motors from the port construction company.

b. Tugs. These vessels tow lighters, barges, or rafts, and assist ships in berthing and unberthing.

c. Amphibian vehicles. These units handle cargo during beach operations. If available, they supply an offshore construction job.

d. Floating cranes. These are available to transportation or engineer units.

e. Floating pile drivers. The engineer port construction company provides either the drop hammer or diesel-powered hammer floating pile drivers. See Figure 4-1, page 4-4.

f. Floating marine repair shop. This shop includes fully equipped machine, electrical, engine repair, carpenter, blacksmith, pipe, and welding equipment. Mounted on a nonself-propelled barge, it is used to repair floating equipment in harbors and adjacent areas. It may be used when opening and rehabilitating captured ports.

g. Landing craft. During the first phase of rehabilitation or new port construction, LCMs deliver construction material, equipment, personnel, and supplies over beaches.

CLASS IV SUPPLIES

Class IV supplies include construction materials and installed equipment. After initial occupation, supplies received from the continental United States (CONUS) follow an automatic rate prescribed by Department of the Army. At a later stage, the basis of supply changes from automatic shipment to requisition. Theater requisitions for engineer construction materials must include project requirements for special large-scale operations. Issues from stocks are based on these requirements. The G-4 approves issue of critical items of Class IV supplies. Uncontrolled items are issued on call.

AVAILABILITY OF LOCAL MATERIALS

Providing engineer construction supplies to a modern Army from CONUS is a large, complex, and costly operation. Local procurement is better where possible. The project officer maintains a continuous inventory of stocks of construction materials and equipment available locally. Class IV supplies suitable for local procurement may include lumber, cement, structural steel, sand, gravel, rock, plumbing and electrical supplies, hardware, and paint.

AVAILABILITY OF LOCAL LABOR

Local port authorities may provide technical assistance on electrical circuits, operation of tidal locks, and cargo-handling equipment. They may also give information on foundation conditions. Personnel in port reconstruction units should draw experience from civilian construction firms. Prisoners of war may be a source of highly skilled workers.

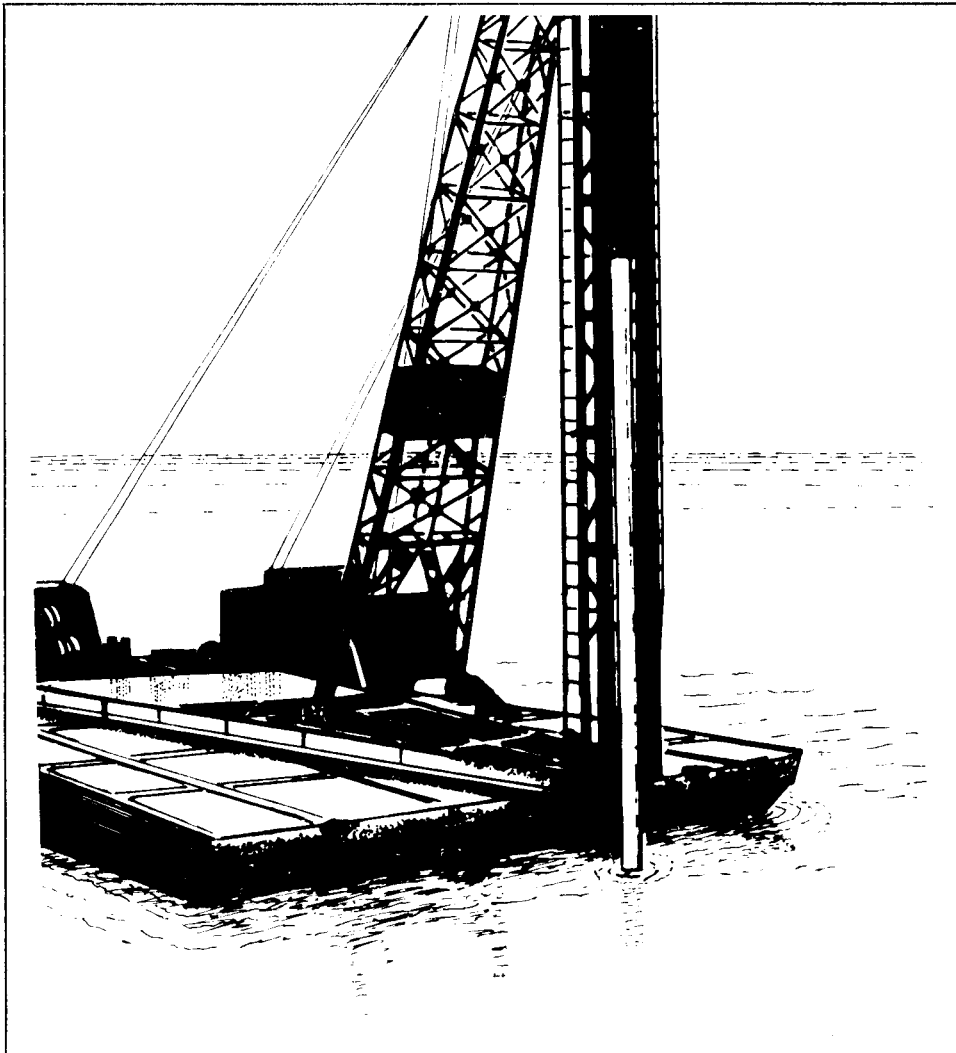

Figure 4-1. Floating Pile Driver

CONSTRUCTION PLANNING

a. Planning stage (TM 5-333). Military construction makes it advisable to divide the planning phase into two stages:

(1) Preliminary. This consists of a quick overall review of the assigned task and the capability of the constructing unit. It includes an estimate of critical items to be procured. Preliminary planning guides the detailed planning which follows.

(2) Detailed. This results in an estimate of the materials, labor, and equipment needed to accomplish each sub-task in the project and a time schedule for the entire project. It includes--

- * Review of drawings and specifications.
- * Detailed estimates.
- * Schedules.
- * Procurement.
- * Construction plant layout.

b. Construction schedules. Construction schedules for projects may be represented by a bar diagram or a network analysis. A major port construction or rehabilitation project uses the critical path method (CPM) of network analysis. The CPM provides a method of handling critical tasks which sets the duration of the project. It warns the manager where he can expect trouble in meeting schedules.

c. Progress reports. The CPM helps to predict the day-by-day progress in terms of percentage of completion. Daily reports indicate how the job stands.

d. Allocation of equipment and material. The CPM indicates tasks engineers must do in early phases of construction to maintain the scheduled rate of progress. Priority goes to securing material and equipment required for these tasks. Tools and equipment are assembled in advance and prepared for use.

e. Delivery schedules for materials.

(1) General. Schedules for the delivery of material depend on site conditions, construction methods, work priority, and availability of supplies. The CPM can establish the materials required and the date they must be on the site.

(2) Bill of materials. Consolidated list of required materials.

PHASES OF RECONSTRUCTION

Port reconstruction is generally carried out in three phases:

a. Phase One.

(1) Subject to operation orders, the Navy carries out major clearing, salvage, and dredging for channels and slips. In an area intended as a naval base, Navy units construct other facilities. In areas intended for ground-force use, the Navy only opens waterways and frees them from mines and similar hazards.

(2) Operation orders for the assault of a port area state the engineer missions in the port area as well as arrangements for liaison between ground forces and naval units.

(3) During phase one, engineer construction units reconnoiter harbor facilities and routes of communication. They note beach improvements and interim facilities available from shore-party activities. They restore any accessible deep-draft or lighter wharfage not heavily damaged. They consider possible uses for vessels sunk alongside piers or wharves, and consult naval units for advice and assistance in improvising wharf decks over their hulls.

b. Phase Two.

(1) Initial construction: Engineers rehabilitate existing port structures. They use expedient methods of lightening and port construction to handle cargo.

(2) Existing noncontainer cargo ports.

- * Continuation of Phase One by shore parties.
- * Construction of floating wharf structures with Navy pontoon gear or Army floating bridge equipment, if available.
- * Erection of self-elevating DeLong barge piers, if available.
- * Expedient repair of existing structures.
- * Lightering with TOE equipment.

(3) Existing container ports.

- * Continuation of Phase One by shore parties.
- * Construction of floating container wharf causeways with modified Navy pontoon gear and self-elevating DeLong barges.
- * Repair of existing container wharves by any expedient method possible.
- * Lightering with TOE equipment.

(4) Future military container ports. Current recommendations are that all military ports constructed in the future be suited for container handling. The recommended design specifies the use of large self-elevating, spud-type barge pier units. These can support live deck-loads of 1,000 pounds per square foot. These barge pier units are equipped with pedestal-mounted off-loading cranes and self-propelled engines. They can be raised or lowered 50 feet per hour. This capability allows undamaged units to perform the following tasks during rehabilitation:

- * Serve as lighters during repair of the damaged units.
- * Form into smaller freed-pier units, depending on the size of ships to be accommodated.
- * Use pedestal-mounted off-loading cranes in clean-up operations.

c. Phase Three.

(1) Existing noncontainer ports.

* Repairable wharf structures are now permanently rehabilitated. Structures are limited to a live-deck load of 500 pounds per square foot.

* New unloading facilities are constructed. Plans for standard structures limit the live-deck load to 500 pounds per square foot.

* Work on highways, railways, canals, and storage facilities outside the wharf area of the port continues. It must keep pace with the development of berthing and unloading facilities at the waterfront.

(2) Existing container ports. Similar to the third phase of existing noncontainer ports, but special designs or modified AFCS designs for port decks must support live loads of 1,000 pounds per square foot or more.

(3) Future military container ports. Recommended designs for future military container ports are planned for expedient construction. The third-phase work for these ports is limited to adjoining facilities.

CLEARING UNDERWATER MINES AND OBSTRUCTIONS

The detection and removal of underwater mines and obstacles are naval specialties.

a. Obstructions. Berths, slips, and channels may be blocked by sunken ships, vehicles, debris, and rubble.

b. Harbor clearance. Naval units perform large-scale underwater clearing and salvage. Engineer units may assist or provide equipment and operators.

c. Sweeping. After mine clearance, naval units sweep the water area to locate underwater obstructions.

INSPECTION OF DAMAGE AND DETERIORATION

a. Conventionally constructed port structures.

(1) Rehabilitation. The decision to rehabilitate or abandon port structures depends on the extent of damage, importance of the structure, and limits on its use.

(2) Wharf inspection. A wharf inspection includes--

* An underwater inspection by divers to check for possible demolition damage or deterioration of footings.

* An inspection of the piling at low water from a boat to check for decay, borer attack, or other damage. The stringers and deck are examined from below to determine the need for repair.

b. Expediently constructed port structures of the future. All military ports constructed in the future should handle the largest containers (67,200 pounds gross weight) within the U.S. container inventory. The most promising design is the large self-elevating, spud-type barge pier discussed in Chapter 11. This pier allows structural items to be inspected above water for damage.

c. Harbor inspection. Breakwaters, jetties, or seawalls are inspected for damage. If breached, such structures are repaired to avoid scour and further damage.

REPLACEMENT AND MAINTENANCE

Repair corrects damage to facilities. For conventional and proposed construction, repair maintenance consists of the following:

a. Emergency repair. Engineers repair storm, accident, or other damage to forestall further loss and larger repairs. Included are--

- (1) Repairing breached breakwaters.
- (2) Repairing wharf damage to restore structural strength.
- (3) Dumping rock to control foundation scour or beach erosion.

b. Major repair. Major repair is replacement work of nonrecurrent nature, such as--

- (1) Replacing wharf decks.
- (2) Resurfacing access roads and earth-filled quays.
- (3) Replacing wharf bracing and anchorages destroyed by decay or corrosion.
- (4) Replacing entire spud barge piers, spuds, or other major barge pier accessories.

REHABILITATION OF LOCKS AND BREAKWATERS

a. Rehabilitation of locks. Gates are repaired only when they are essential to full operation of the facility.

b. Rehabilitation of breakwaters. Repair of breakwaters and similar structures protects the characteristics of a harbor. Use suitable rock to repair breached breakwaters.

CHAPTER 5 BREAKWATERS, ANCHORAGES, AND MOORINGS

BACKGROUND

a. General. Natural processes are continually at work molding coastlines. They may be temporarily eroded by storm waves and later partly or wholly restored by swells. Erosion and build-up patterns may also occur seasonally. Human settlement along the shore may alter these natural processes. The long-range condition of the beach (whether eroding, stable, or building up) depends on rates of resupply and loss of littoral material. After engineers build ports, they cannot allow the shoreline to migrate either landward or seaward. It is needed to protect shoreside facilities.

b. Natural protection. Where a sandy beach meets the ocean, it has protection against waves, currents, and storms. The slope of the bottom causes waves to break and dissipate their energy offshore. This process often creates an offshore bar in front of the beach to trip the following waves. The top wave uprush forms a ridge of sand. Beyond this ridge lies the flat berm reached only by storm waves. Figure 5-1 shows a beach profile with its related terminology. Winds blowing inland move sand behind the beach to form dunes. Dunes are the final natural protection line against wave attack, acting as a reservoir for storage of sand against storms. Grass, shrubs, and trees may grow on the dunes as part of a natural levee against sea attack.

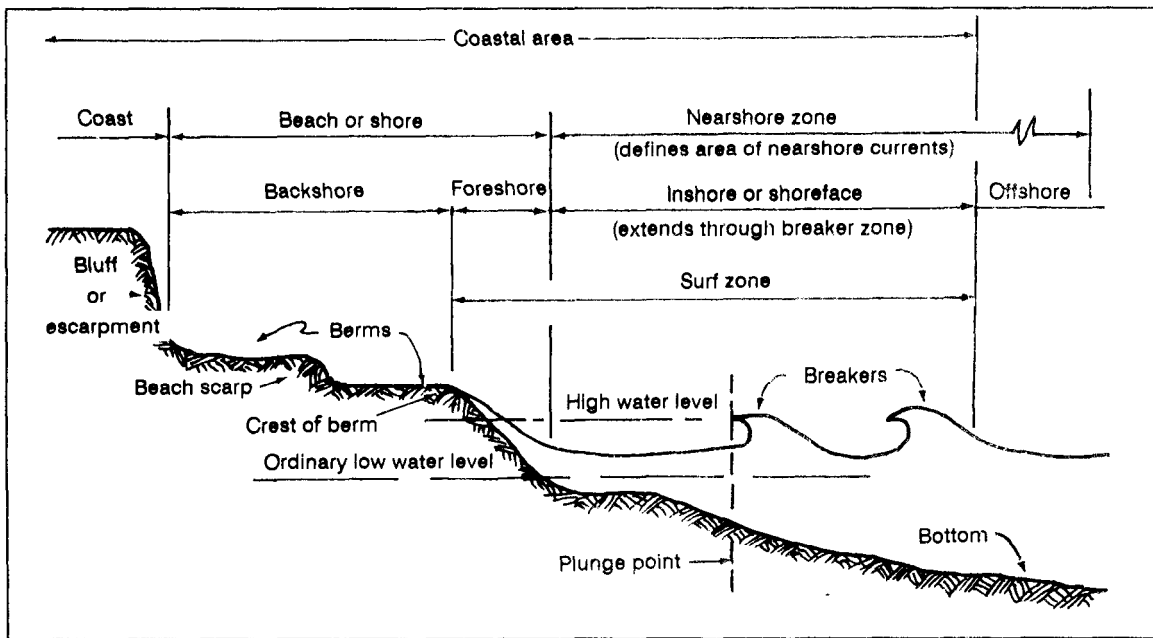

Figure 5-1. Beach Profile

c. Functions of shore protection methods. Beaches and dunes may adequately protect shore facilities; however, natural forces sometimes cause erosion as storm waves overlay the beach and damage backshore structures. Man-made construction must then provide additional protection. Generally, measures to stabilize the shore fall into two classes. The first are structures to prevent waves from reaching erodible materials: seawalls, bulkheads, and revetments. Other man-made structures such as groins and jetties may retard littoral drift. The second measure is an artificial supply of sand to make up for a lack of natural sand.

Section I. Breakwaters

a. Definition. A breakwater is a structure protecting a shore area, harbor, anchorage, or basin from waves. It creates calm water and gives protection for safe mooring, operating, and handling of ships, as well as protection for harbor facilities.

b. Types.

(1) Offshore breakwaters. Rubble-mound in the United States.

(2) Shore-connected breakwaters. Rubble-mound, composite, concrete-caisson, sheet-piling cell, crib, or floating. The special advantages of rubble-mound breakwaters should be considered first.

(3) Rubble-mound breakwaters.

(a) Advantages.

- * Can be machine constructed and placed.
- * Able to rest on any foundation.
- * Capable of withstanding breaking waves.
- * Resistant to damage from severe storms.
- * Allows inexpensive construction and renovation.

(b) Design. Engineers study existing rubble mounds in conditions similar to the proposed breakwater site. They adapt the design according to these principles:

* Waves breach the mound either by overturning the stones or by pulling them down. The slopes of the rock mound absorb the energy of the waves dissipated in shocks, friction, and eddies. The disturbing influence of waves is most keenly felt between the levels of high and low water.

* The mound must have adequate height to provide the desired degree of protection.

(c) Height determination. The greater the exposure, the higher the crown of the mound should be above the water level. Practical experience determines the economical height to break the wave and prevent it from rolling over the mound. The design should show an initial height above high water level equal to at least two-thirds the maximum expected wave height above mean high water (Figure 5-2). When water levels fluctuate, height increases according to the tide range. If the height proves inadequate, add more materials.

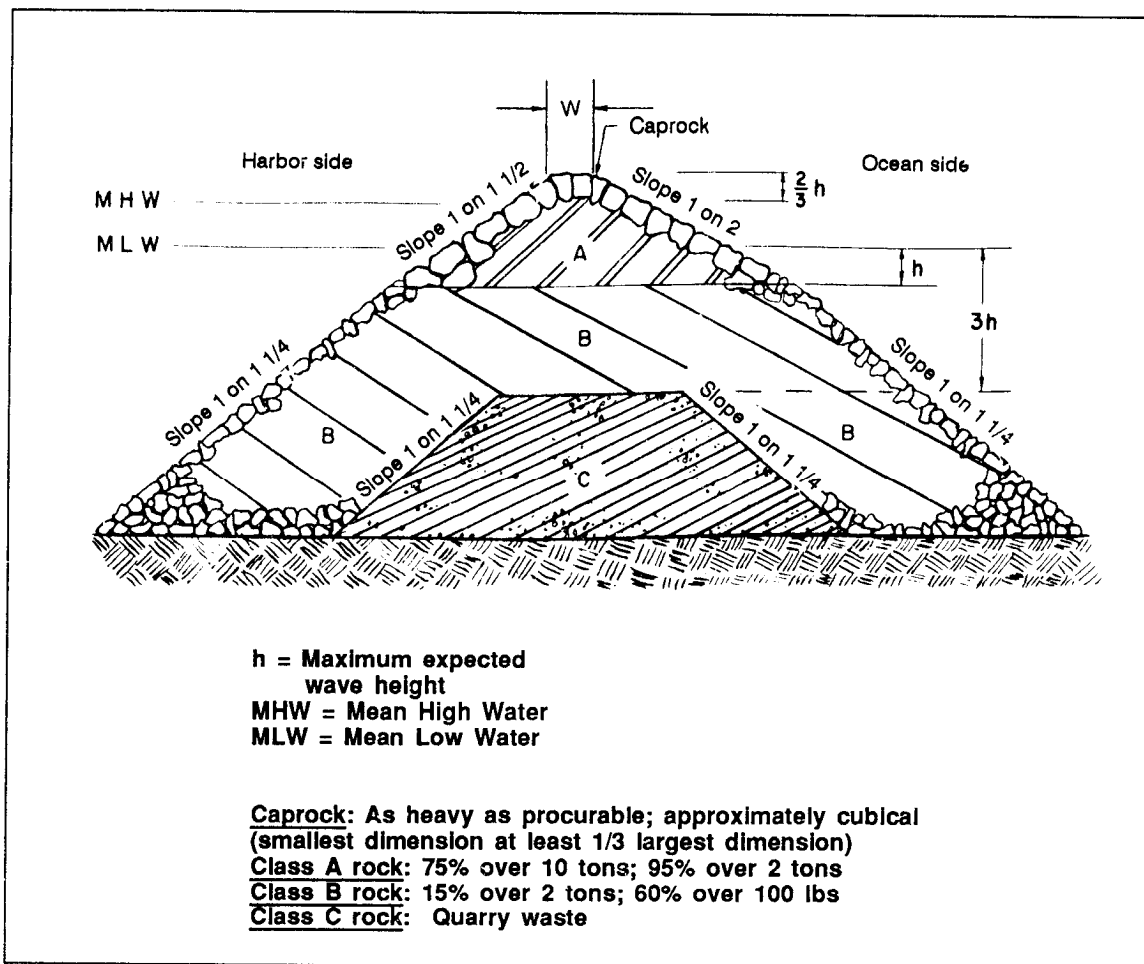

Figure 5-2. Rubble-Mound Breakwater

(d) Width determination. The width of the base is influenced by the slopes assumed by the mound under wave action. Engineers must determine the width of the crown or top. When the mound is exposed to ocean storms, a 15- to 20-foot wide top has proven adequate. Severe wave action calls for tops as wide as 70 feet. Constant hydrodynamic action requires the use of heavy material in the mounds. The width should be enough to prevent the mass of water from falling on the harbor side.

(e) Slope determination. Below a certain depth, the mound generally assumes a natural slope ratio that does not exceed 1 vertical on 1 1/4 horizontal. Above this depth the mound is subject to the direct impact of the breaking waves. Below, it is subject to the secondary currents set up when waves meet the breakwater. The slopes above this depth flatten considerably. The surfaces of the mound are protected by carefully laid stones weighing from 10 to 20 tons. Sea slope ratios may vary from 1 vertical on 1 1/2 to 3 horizontal. On the harbor face, a slope ratio of 1 vertical on 1 1/2 to 2 horizontal is usual.

(f) Placement of material. Tests indicate the following cross section for a bottom 60 feet below mean sea level (-60 msl).

* In placing unprotected Class C core material, the top elevation of the section should not exceed -20 msl for waves 7- to 8-feet high. It should not exceed -30 msl for waves 10- to 11-feet high; -40 msl for waves 15- to 16-feet high; and -50 msl for waves 20- to 21-feet high.

* Class B material should be placed on both landward and seaward slopes while still placing the Class C core material. This should start when the Class C section has been filled to an elevation of -50 msl. Placing Class B material on only one side of the slope is unsafe.

* The top elevation of the Class B section should not exceed -20 msl for waves 15- to 21-feet high. Heavier and larger Class B stone must be placed on a flatter slope than is shown in Figure 5-2, page 5-3.

* For waves 15- to 21-feet high, the seaward slopes of the mound should be on a slope ratio from 1:2 to 1:2-1/2. Use the same design slope given in Figure 5-2. Heavier or larger stone should be used for both Class A and Class B sections. The top elevation of the Class B section should be lowered to about -20 msl. This increases the amount of Class A capstone.

* For 21-foot or larger waves, the ratio of the upper sea-slope should be 1 on 3 with individual surface stones of 15 to 20 tons. The lower slope ratio should be 1 1/2 with Class B rock up to 2 or 3 tons. The interlocking effect of packing or wedging large stones into place increases the strength of the breakwater; so does placing rectangular blocks in close rows. To protect against scour, a riprap belt of Class A material should be placed on a 1:1 slope alongside the seaward toe of the mound. If the outer slope slips, it loses the benefits of packing or wedging stones in the upper face.

* Rubble mounds are exposed mostly at the ends. Therefore, the ends are built higher, wider, and of larger rock to resist the greater wave force. Monolithic blocks of concrete, up to 10 by 40 by 100 feet, are sometimes cast in place on top of such terminals. These large masses hold the rubble mound intact. Where rock is scarce, rubble mounds have been rehabilitated by casting concrete blocks 4 by 8 by 30 feet on top of the sunken mound.

(g) Construction methods. Rubble mounds are built by dumping scows. They use floating cranes for the upper course or dump from rail cars on a track carried on pile bents.

Section II. Wave-Resistant Walls

The upper beach which fronts onshore development requires artificial protection as a the natural protection lost during construction. Engineers have built walls, such as bulkheads, revetments, groins, jetties, and seawalls to serve as

BULKHEADS

a. General. Bulkheads retain beach-fall material and do not feel severe wave action. Bulkheads may be concrete, steel, or timber (Figures 5-3 through 5-5). Cellular steel sheet pile bulkheads are used where rock is near the surface and where anchored sheet pile bulkheads cannot penetrate adequately. Bulkhead designers should consider the effect of scouring at the base. They may need riprap armoring. Sheet piles must be adequately reinforced for bending moment, soil conditions, hydrostatic pressures, and support points. The first pile must be driven accurately, maintaining good alignment. Design may require a timber aligning frame. The frame has double rows of studs with one or two rows of wales spiked to them. In very plastic soils, it also has diagonal bracing to align the sheet piles.

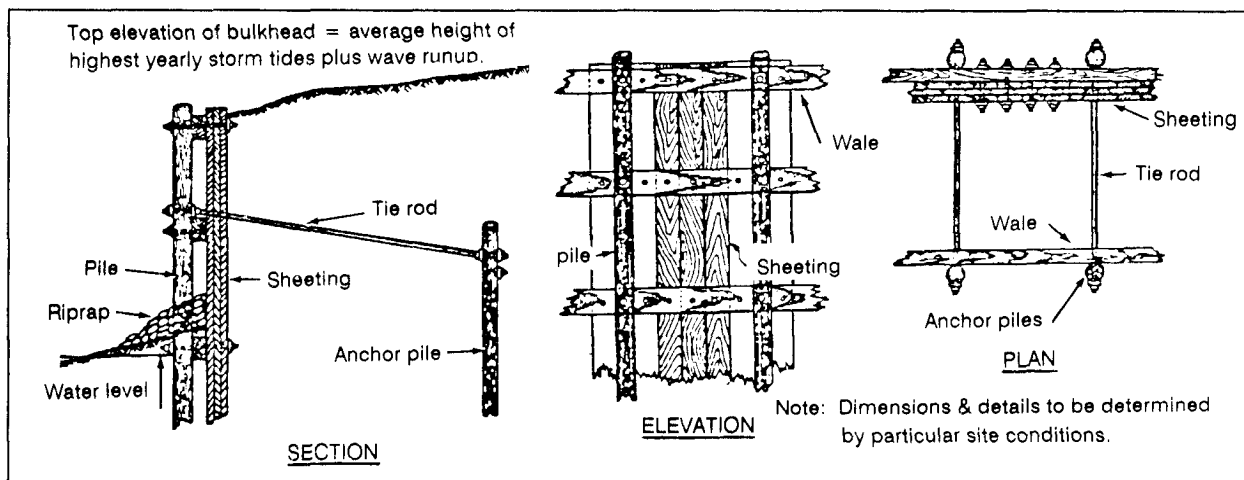

Figure 5-3. Timber Bulkhead

b. Steel sheet pile. There are two methods of driving steel sheet pile:

(1) Drive a single or a pair of piles simultaneously. This method keeps the driving leads vertical and stable with the hammer centered over the neutral axis of the pile. It requires a firm, level foundation for the pile-driving equipment. Z-piles are driven in pairs.

(2) Assemble all piling in a wall form first, then drive them continuously along the line. This method requires that the piling be set with both axes plumb. Hold the hammer rigid; vibration in the hammer or the pile drives the piles out of alignment.

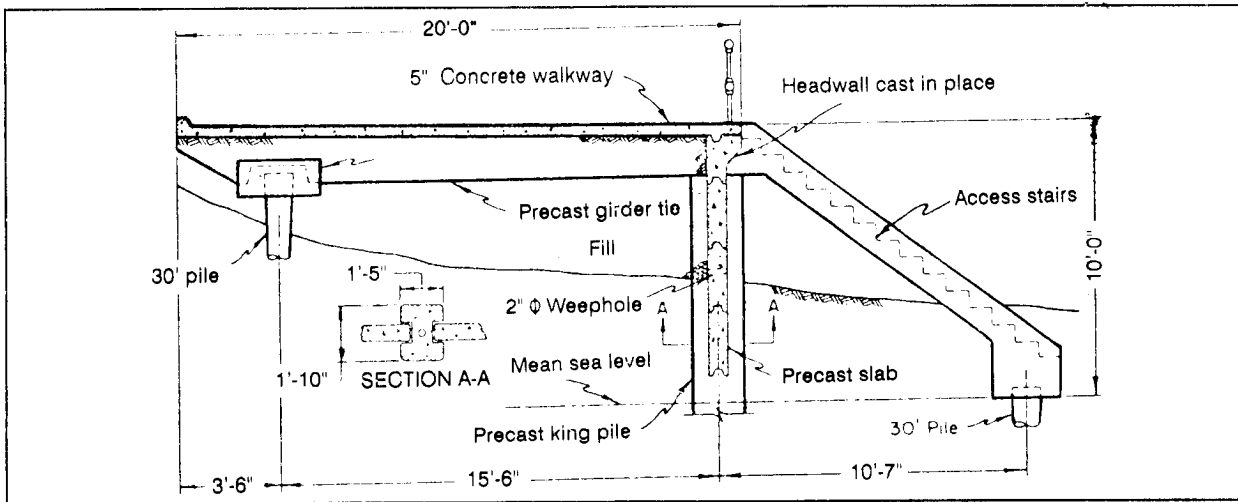

Figure 5-4. Concrete Bulkhead

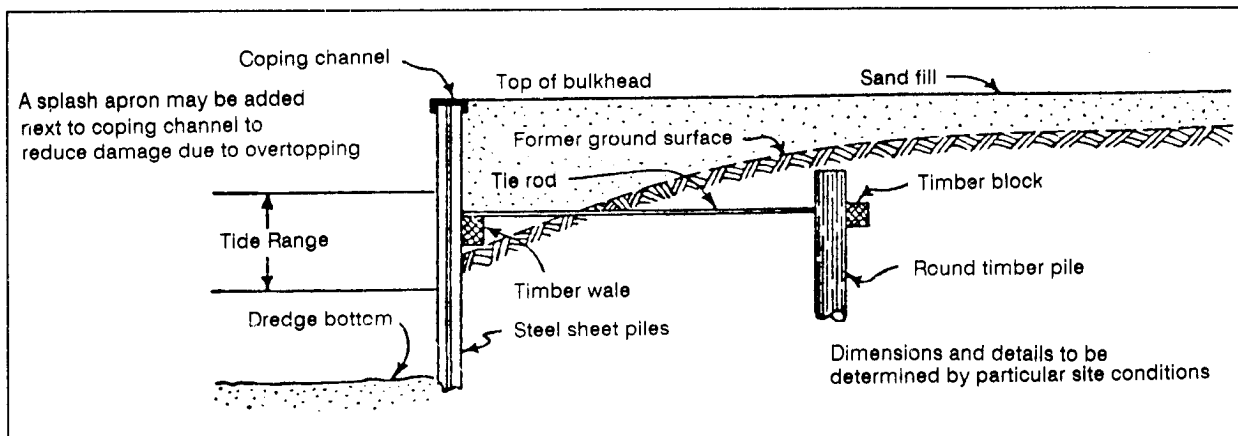

Figure 5-5. Steel Bulkhead

(3) Short piles driven in soft ground are driven to full depth singly or in pairs. Long piles and hard ground may cause creep. Creep is prevented when--

- * Guide waling is set along the sheeting line.
- * A pair of sheet piles is driven partway.
- * A panel of a dozen single piles or pairs is set in the walings.
- * The last pile or pair of piles in the panel is driven partway.
- * The piles between the first and last pile or pair of piles are driven to full depth.
- * The first pile is driven to full depth. The last pile is driven to two-thirds depth, to act as a guide for the first pile of the next panel.

(4) Soft ground may draw piles down. To counteract draw-down, bolt the piles to stiff waling. A pile that has been drawn down is not jacked up, instead, an additional length is welded onto it.

c. Concrete sheet pile. The foot of a concrete sheet pile is often beveled on one side. This forces the pile against an adjacent pile to maintain contact during driving. Jetting is frequent. If a watertight wall is required, joints are usually grouted after driving. The soil at the bottom of the pile is flushed out with a water-jet pipe long enough to reach the bottom of the pile. A tremie is used to place grout underwater. Concrete is placed in the tremie and deposited. Flexible fillers may be placed in joints at 25- to 50-foot intervals. If a cap is placed on the wall, the flexible joints are continued through the cap.

d. Timber sheet pile. Timber sheet pile bulkheads are used at the inshore end of wharf structures.

REVTMENTS

Revetments protect the shoreline against erosion caused by currents and waves. There are two types of revetments. One is the rigid, cast-in-place concrete type, which gives excellent bank protection. The site must be drained during construction to place the concrete. The other revetment is the flexible or articulated armor-unit type. This revetment also provides excellent bank protection and can tolerate minor consolidation or settlement without structural failure.

GROINS

a. General. A groin is a shore-protection structure that adds to a protective beach or retards erosion of an existing or restored beach. Groins trap material being moved by wave-generated littoral currents. Groins are classified by permeability, height, and length. Common construction materials for groins are stone, concrete, timber, and steel. They can be built of these materials and still be permeable or impermeable; high or low. Asphalt and sand-filled nylon bags have also been used.

b. Timber groins. A common type of timber groin is an impermeable structure composed of sheet piles supported by wales and round piles. Some permeable timber groins have spaces between the sheeting (Figure 5-6).

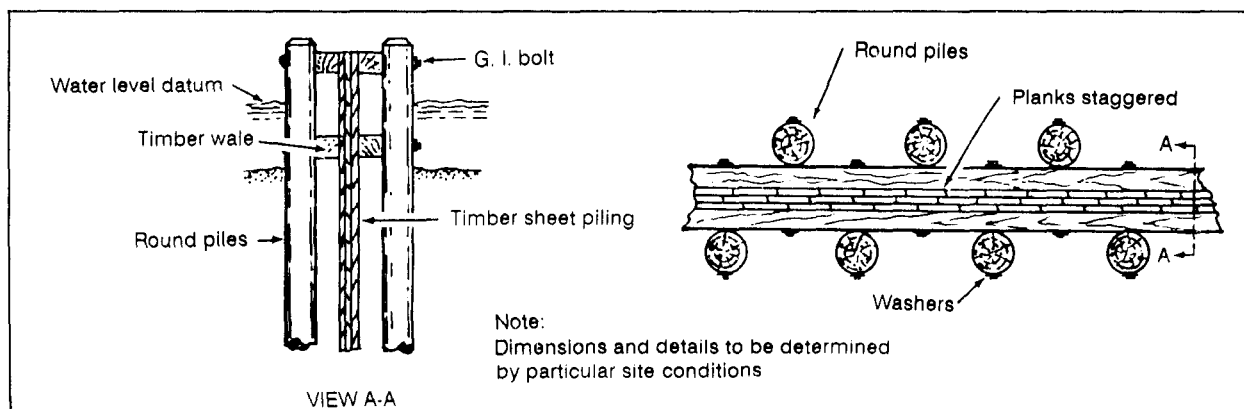

Figure 5-6. Timber Groins

c. Steel groins. A typical design for a cantilever steel sheet pile groin is shown in Figure 5-7. Steel sheet piles have been constructed with straight web, arched web, and Z-piles. The interlocking type joint of steel sheet piles provides a sand-tight connection. The type of sheet pile used depends on the earth forces to be resisted. Cellular steel sheet pile groins serve where adequate pile penetration cannot be obtained for a foundation (Figure 5-8).

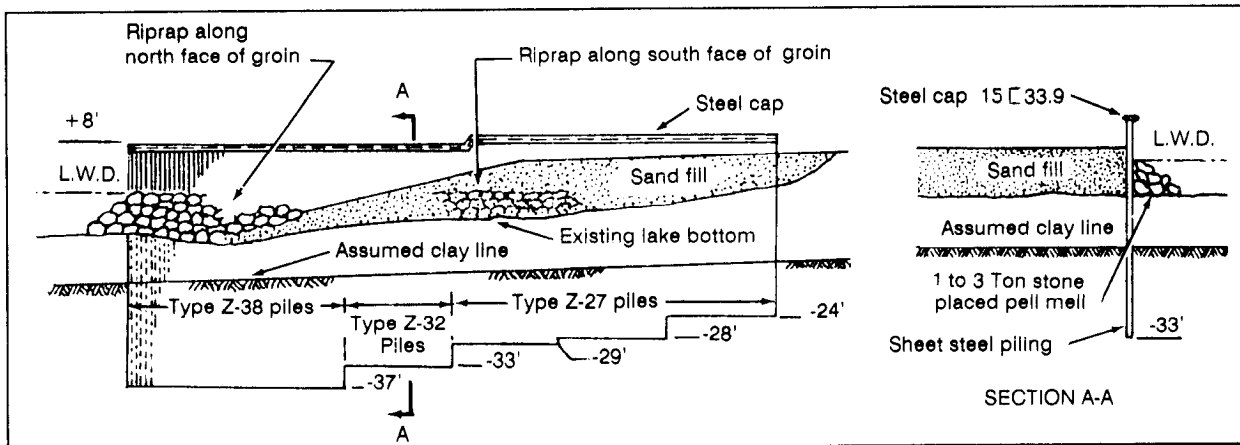

Figure 5-7. Steel Groins

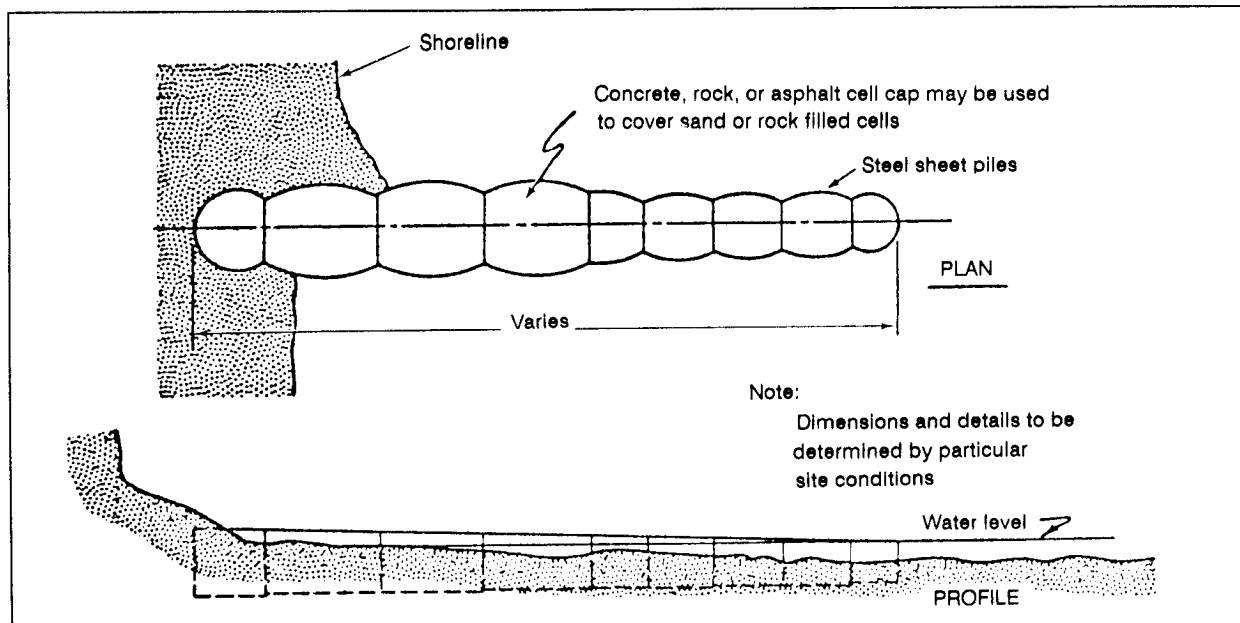

Figure 5-8. Steel Sheet Pile Groins

d. Concrete groins. Concrete in groins was previously limited to permeable structures that permitted sand to pass. Figure 5-9 shows a more recent development in concrete groin construction. The groin is an impermeable, prestressed concrete pile structure with a cast-in-place concrete cap.

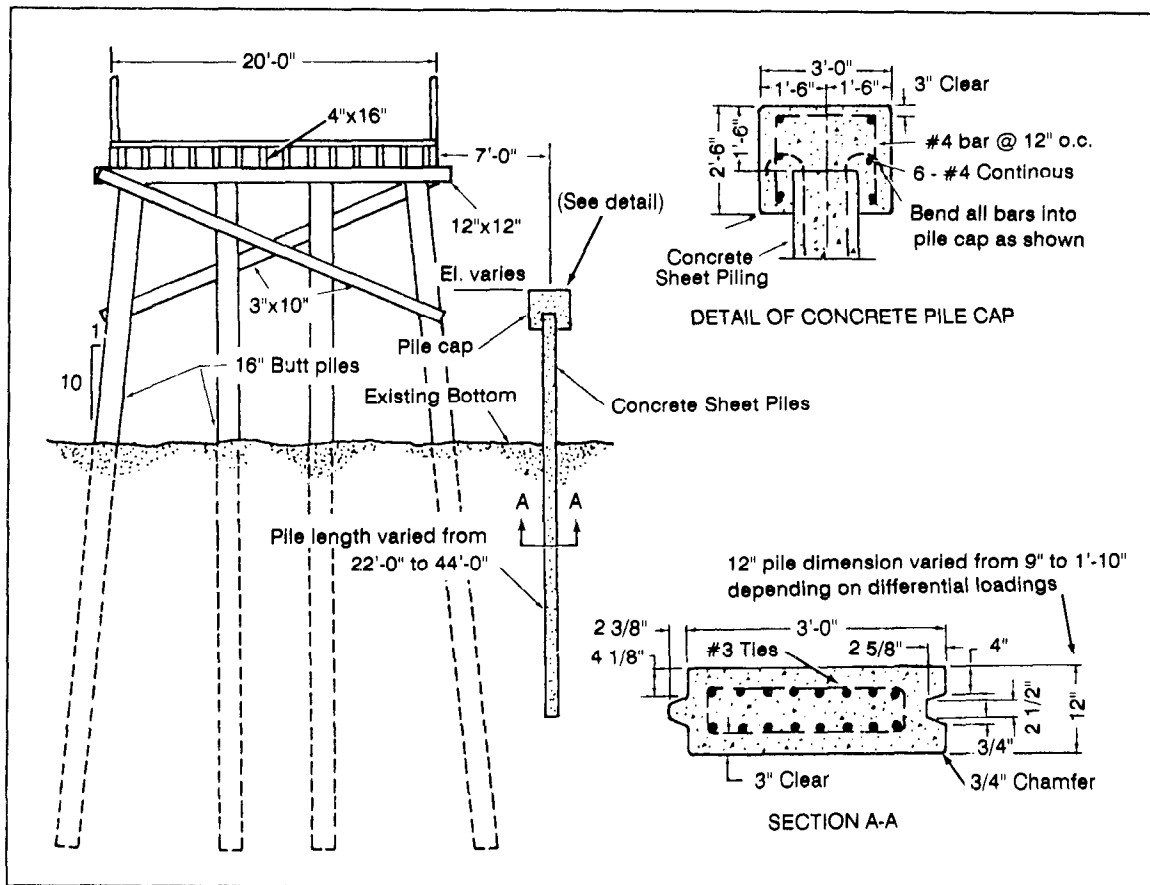

Figure 5-9. Cast-in-Place Concrete Groin

e. Rubble-mound groins. Rubble-mound groins (Figure 5-10, page 5-10) have a core of quarry-run material, including fine material to make them sand-tight. They have a cover layer of armor stone.

f. Normal method of construction. Groins are narrow and stand perpendicular to the shore. They extend from a point landward of predicted shoreline recession, reaching far enough into the water to accomplish their purpose. They vary from less than 100 feet to several hundred feet. Most of the littoral drift moves in the zone landward of the normal breaker zone. Extending a groin of that depth seaward is costly.

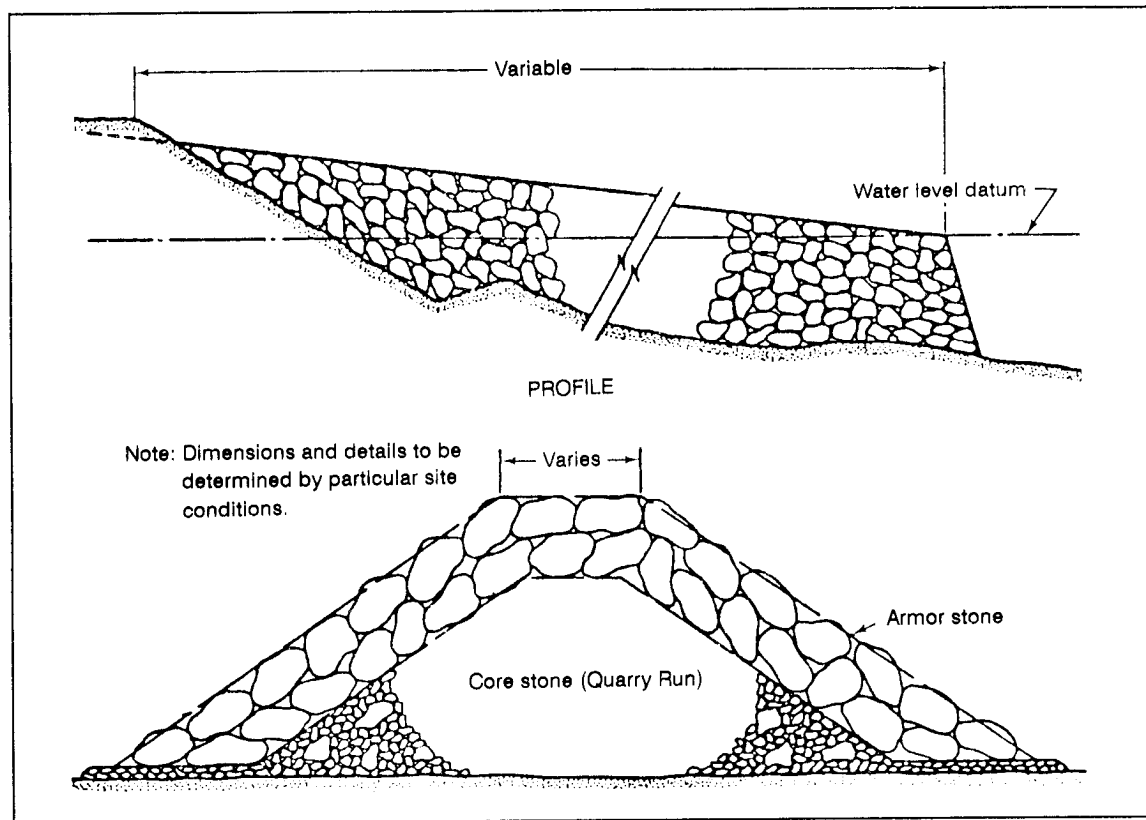

Figure 5-10. Rubble-Mound Groin

JETTIES

a. General. Jetties are designed to control movement and shoaling in channels. Similar to groins, they are usually made of stone, concrete, steel, or timber. Asphalt is sometimes used as a binder.

b. Rubble-mound jetties. Rubble-mound structures are mounds of stones of different sizes and shapes that are either dumped at random or placed in courses. Side slopes and stone sizes are designed to resist wave action. If cheap rock armor units in adequate quantities or size are not available, use concrete armor units. Various shapes of concrete armor have been tested and are available. Figure 5-11 shows quadripod armor units used in jetty construction.

c. Sheet pile jetties. Timber, steel, and concrete sheet piles have been used for jetty construction where wave action is not severe. Cellular steel sheet pile structures require little maintenance. They are suitable for construction in depths to 40 feet on all types of foundations.

d. Normal method of construction. Jetties built on the U.S. open coast are generally rubble-mound structures. In the Great Lakes, engineers have built jetties of steel sheet pile cells, caissons, and cribs, using timber, steel, or concrete. In sheltered areas, they have used a single row of braced and tied wakefield timber piling and steel sheet piling.

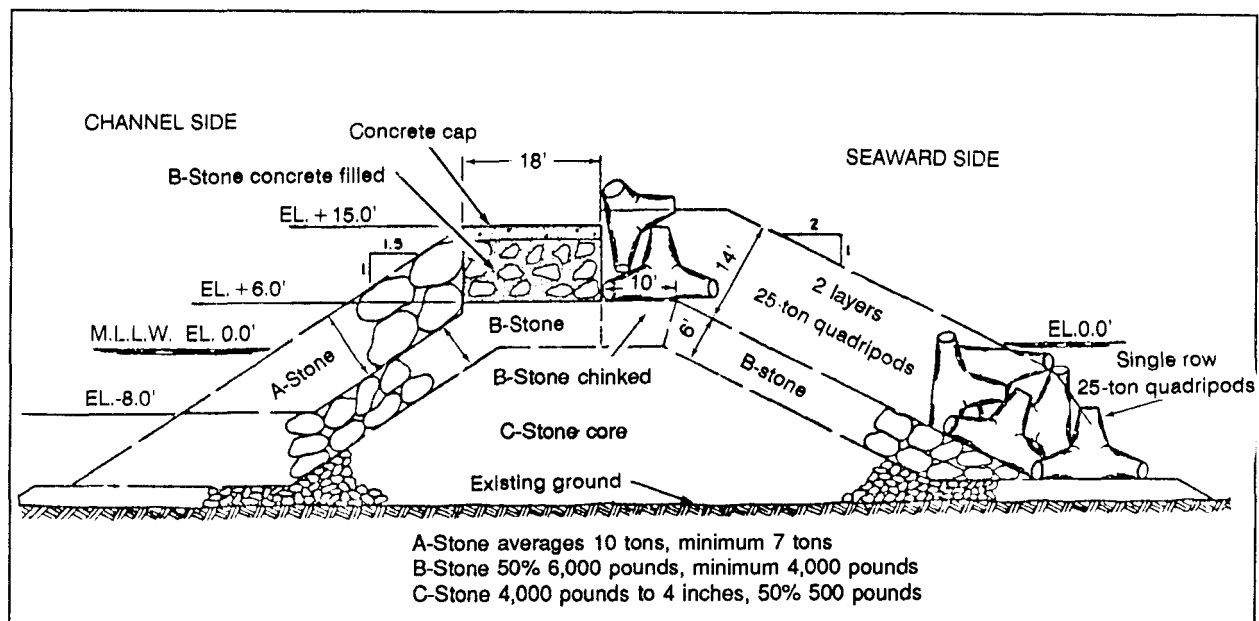

Figure 5-11. Quadripod Armor Units in Jetty Construction

SEAWALLS

a. General. A seawall is a vertical, sloping, or stepped wall which protects a shoreline from erosion and other wave action. Seawalls are normally constructed of concrete or stone masonry. However, engineers have had some success with designs using steel, timber, and rubble.

b. Masonry seawalls. Seawalls resist the full force of waves. They are designed as massive gravity-type retaining walls, with additional stability to resist wave and storm action. A curved-face seawall and a combination stepped and curved-face seawall are shown in Figure 5-12. Engineers build these structures to resist high wave action and to reduce scour. Both seawalls have sheet pile cutoff walls at each end. These prevent loss of foundation material by wave scour or storm drainage beneath the wall. The curved-face seawall has an armoring of large rocks at the seaward toe to reduce wave scour. Masonry seawalls are constructed as follows--

(1) Cast-in-place concrete. Concrete is deposited underwater for leveling old footings, stabilizing rock fills, or setting new footings or walls. Bottom-dump buckets with closed tops or tremies make the deposits. During placement, the lower end of the tremie is kept below the surface of the fresh concrete. Footing forms are usually light sheet piling. Wall forms are prefabricated and sunk in place.

(2) Precast concrete blocks. First, engineers cast in place concrete footings with level tops; then they set precast blocks in place. These blocks are provided with rings for crane slings. Blocks are set in contact without mortar below low water. Joints are filled with mortar above low water. Divers may position the blocks underwater. The end joints of the blocks may be battered to improve the contact.

(3) Stone masonry. Stone is sometimes a suitable alternative to concrete masonry.

DESIGN REQUIREMENTS FOR SHORE PROTECTION

a. Structural stability. Structural stability is a function of the configured structural material, loads, and foundation characteristics. Loads present the major unknown to the design engineer. Some of the loads considered in the impact are loads from the waves, static loads from surcharged material, and ice and wind loads.

b. Hydraulic effects. Hydraulic design requires extensive model testing. Engineers must avoid the creation of erosive hydraulic actions resulting from structures they build.

c. Environmental effects. The construction of shore protection facilities may result in changes in erosion and build-up. Design engineers must consider the environmental impact of anticipated changes.

d. Materials availability. Theater of operation supplies are scarce and vary from location to location. Necessary materials not readily available must be transported from nearby locations, increasing both the cost and time factors.

MAINTENANCE AND REPAIR

Engineers should keep shore protection structures in good condition. Repairs of major damage should be completed quickly.

Section III. Anchorage

TWO TYPES OF ANCHORAGE

a. Roadstead. Roadsteads (Figure 5-14) are tracts of water near the coastline. They have good holding ground for anchors and some protection from heavy seas. They may be natural or created by placing breakwaters parallel to the coast. The Navy is normally responsible for roadstead layout; however, if Naval support is not available, it may become the responsibility of the port construction unit.

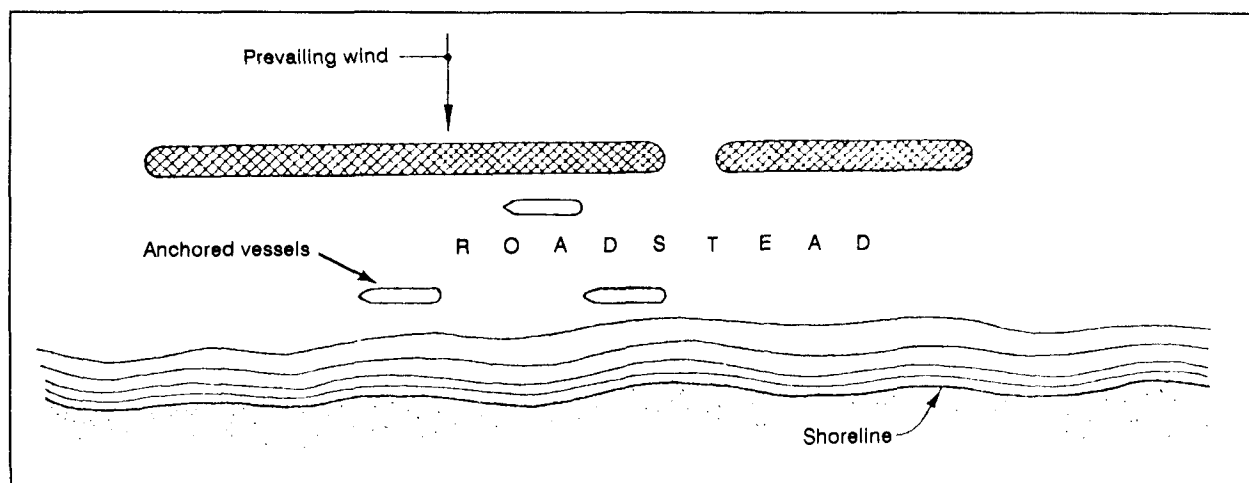

Figure 5-14. Roadstead

b. Harbor. Sheltered anchorages in a harbor permit access for lighters. They are close enough to lighterage wharves to permit rapid unloading. In some locations, breakwaters and jetties can extend the area already protected by natural land forms.

HARBOR DEPTH

Harbor depth varies. Certain areas are set aside for small craft, and other areas for larger ships. Both small- and large-craft areas must have adequate berthing depth at extreme low water. Failure here makes the installation useless. Bottoms of anchorage areas must be firm enough to hold the pull of a ship's anchor or of buoy moorings. They should be free of hulks or large rocks that foul anchors. When considering anchors, refer to Table 5-1 for bottom holding characteristics.

TABLE 5-1. Bottom Holding Characteristics

Type of Anchor	Holding Power in firm sand**
Navy stockless with stabilizers	7 Wa*
Stock (admiralty)	7 Wa
Mushroom	2.5 Wa
Lightweight (Navy)	65 (Wa) ^{0.82}
Concrete anchor (10,000 Wa only)	2.6 Wa
NAVFAC Stato	20 Wa

Notes. *Wa = weight of anchor in air

**For different bottoms, ratio of holding capacity to firm sand:

Well compacted sand	1.0
Stiff, dense, plastic clay	1.5
Cohesive clay, medium density	0.6
Fluid mud, loose sand, gravel	0.3
Rock, shale, boulders	0.2 (Navy stockless only)
Mud bottom	0.7 (NAVFAC Stato only)

ONSHORE MOORING ANCHORS

a. Characteristics. Onshore mooring anchors are clusters of piles similar to dolphins. They are driven onshore rather than in the water. They project only a few feet above the surface. The clusters may be much smaller than the clusters needed for similar loads in deep water. Engineers give onshore mooring piles increased horizontal resistance. They tie them back to buried piles or deadmen. The ties between mooring piles and deadmen should be as high on the anchors as possible. But they must not interfere with ship's lines looped over the mooring pile.

b. Uses. Onshore mooring anchors may serve when wharves are not strong or rigid enough to support the stress applied by a moored ship. Onshore mooring anchors also hold floating causeways or floating wharves in place.

ROCK-FILL TIMBER CRIBS

a. Definition. A crib (Figure 5-15) is a rectangular lattice of logs or heavy timbers used to retain rocks or rubble. It furnishes a foundation, retaining wall, or breakwater.

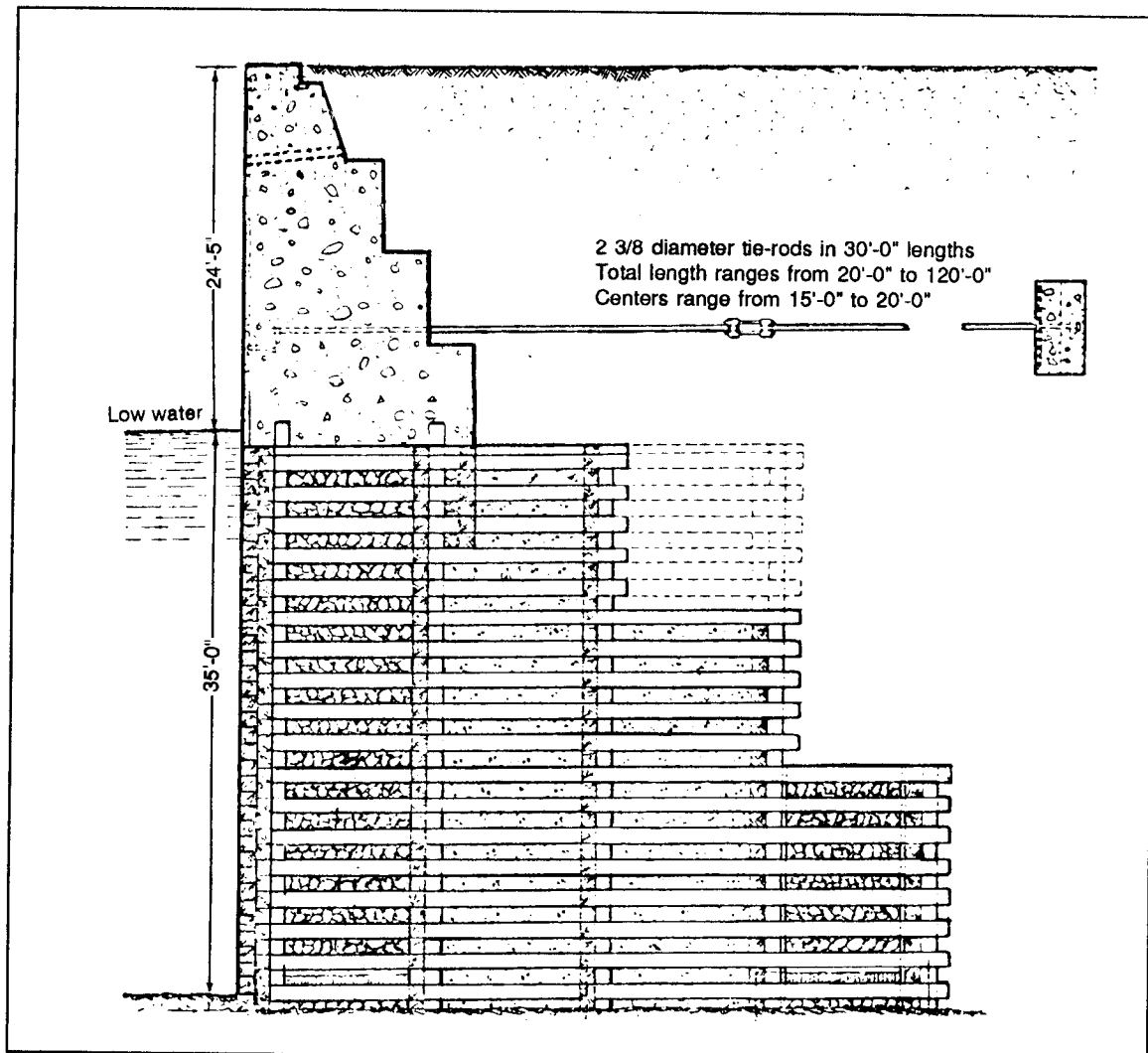

Figure 5-15. Rock-Fill Timber Crib

b. Employment. In the past, rock-fill timber cribs served well in the early construction of piers and wharves, particularly in the Great Lakes. Now they are limited to areas where--

- (1) Bottom conditions prevent driving piles deep enough to give lateral stability.
- (2) Timber lacks adequate length and strength for piling.
- (3) Pile-driving equipment is not available.
- (4) Skilled labor is unavailable or costly.

c. Construction of cribs. Timber cribs may be built with finished lumber (creosoted, if necessary) or with logs. Logs should be flattened at the point of contact. Cribs are built on shore and floated into position. They are then sunk into position on beds of foundation rock or riprap. The top of the timber crib stops at mean low-water level. It is filled with rock or rubble that will not wash out between the interstices. Above low water, the superstructure walls are usually nonreinforced concrete. The lower section just above the timber has reinforced concrete shells or boxes to hold the remaining concrete in place. Ordinary shattering would let currents and surges of the water wash out the cement and honeycomb mass (nonreinforced) concrete. Freezing and thawing can disintegrate the lower part of crib superstructures made only of mass (nonreinforced) concrete.

d. Disadvantages. Severe settlement occurs if the crib foundation cannot support the applied loads.

Section IV. Landing Ramps

a. Uses. In the early development of a port, engineers may build landing ramps for amphibian vehicles and landing craft.

b. Design.

(1) Most landing craft in the current inventory draw from 3 to 4 feet of water at their bows. Beach gradient must be slight enough not to cause grounding at their sterns. Listed craft may require shore landing ramps that extend out from the shoreline to within 20 feet of where the water is at least 4 feet deep during low tides. The gradient of the face of the beach ramp should be about 3:20, or about 15 percent. Ramp material must--

- * Withstand the continuous movement of heavy material-handling equipment while saturated.

- * Give traction to vehicles entering or leaving the craft

- * Be flexible enough to prevent serious damage to the landing craft using it.

- * Resist scour caused by prop wash of landing craft and by currents parallel to the shoreline.

(2) Crushed rock, gravel, and/or small stones are practical materials for landing ramps. They are placed in layers with the larger armor rock in a 5-foot layer on the bottom. The other, smaller rock is placed on top of the armor rock.

(3) Airfield matting is very good for landing ramps and road networks on beach surfaces. It is versatile, reusable, and easily installed and maintained.

CHAPTER 6 WHARF LOCATION AND LAYOUT

Section I. Location

CURRENTS AND SILTING

a. Ship docking requirements. A docking ship may need to turn broadside to a swift wind or current. Thus, the ship exposes a maximum area when it has the least self-control. Every ship needs to dock in a sheltered area, or at least in a place parallel to the wind and current. Mooring best occurs during slack water.

b. Scour. Bottom scour causes problems when currents remove supporting soil around bearing piles or in front of bulkheads. One solution is to drive long steel bearing piles or caissons into a hard nonerodible stratum. Another solution is to provide a rock cover on areas subject to scour.

c. Silting. Any interference with existing currents changes the erosion-deposit pattern. A wharf on solid fill may act like a groin. It creates a current-free backwater for deposits of silt and sand. A structure on pilings or caissons has less effect on the normal flow of the current than one on solid fill.

SUITABLE WATER DEPTHS

a. Water depths for planning purposes. A minimum low-tide water depth of nearly 35 feet has been standard. It accommodates virtually all deep-draft vessels. However, future military ports will require minimum water depths of 40 feet to accommodate containers and large tankers with over 50,000-hundredweight (cwt) capacities. Construction of wharves in water depths several feet less than desired may be justified only where--

(1) Dredging can reach the required depth as a part of the construction. Dredging must not endanger any in-place wharf.

(2) Short-term use is anticipated and lightening is feasible.

b. Minimum water depths. The wharf's intended use (POL, containers, or lighters) dictates minimum water depths for new construction. The operations order gives these depths.

ONSHORE TOPOGRAPHY

The ideal site is smooth, well-drained, and has open terrain. It is trafficable, has easy slopes, and stands above the reach of seas and swell. In undeveloped areas before invasion, planners may not detect features such as major swamps inshore of beaches. These may require major changes in planning. They may even require relocating the port. Shore traffic needs space for covered storage, container storage, marshaling areas, and bulk petroleum-handling facilities. Space is also needed for construction, operation, and supply units. Good, deep-water approaches with efficient road and rail connections are more important than onshore topography.

ROAD AND RAIL CONNECTIONS

a. Background. In the past, engineers have found it helpful to rehabilitate existing general cargo ports. Frequently, these ports already have rail and road nets suitable for most cargo handling. However, future ports must handle containers. If existing ports were not designed for container handling, engineers must develop new container ports. They must also rehabilitate and improve existing rail and road nets to accommodate containerized cargo.

b. Road nets. There are four pieces of line-haul equipment now scheduled for containers. They are the dual purpose 22 and 11/2-ton tactical break-bulk/container transporter; the dual purpose 34-ton break-bulk/container transporter; the commercially designed 6 by 4 truck-tractor; and the 5-ton, 6 by 6 tractor, M818. This equipment allows use of current roadway design criteria, with maximum grades of 10 percent, and maximum curves of 38 degrees. Steep grades, sharp curves, and unsurfaced roadways reduce efficiency, especially when transporting containers. They are hazardous. Surfaced roadways should have maximum grades of 6 percent on tangents and 4 percent on curves. Curves should not exceed 14 degrees for container operations.

c. Rail nets.

(1) Importance of rail nets. According to TM 5-370, "When available and when they can remain operable, railroads are the most effective and expeditious form of transport in a theater of operations." However, containers make railways only the second most effective means of supply transport. Tractor trailers with containers are the most effective.

(2) General specifications. Railway grades of more than 2 percent or railway curves of more than 12 degrees are dangerous, especially where grade and curvature combine. Thus, many otherwise satisfactory ports have rail connections from the wharf requiring racks too long to keep the grade within normal limits. One alternative is to use a pusher grade on the first division inland. Another is a truck-served rail terminal inland of the port.

OPEN AND COVERED STORAGE

Current Army guidelines for support of operations assume depot supplies will be uncrated and ready for issue. However, containerized supplies will comprise the bulk of all shipping in the future. Modern commercial container ports provide from 12 to 18 acres of storage and marshaling area per ship berth. These acres hold 1,000 40-foot, 67,200-pound containers or their equivalents. Military storage and marshaling areas should have at least 12 acres per ship berth. This area is served by modern material-handling equipment, such as front loaders, side loaders, and straddle carriers. Non-containerized supply storage estimates may differ for each port.

EXPANSION PROVISIONS

Port planners must first consider meeting immediate needs. Engineers must provide the most facilities in the least time. They continue development as originally prescribed or as redefined. Planning provides for expansion later. Provisions for expansion, as shown on layouts, include the following--

a. Extending piers or converting marginal wharves into piers. Tolerance is essential in water depths, pierhead limit lines, water approaches, original widths of piers and slips, and onshore transportation and storage facilities.

b. Expanding lighterage by converting swinging anchorages to fixed bow-and-stem. In sheltered waters, with more wharf use by lighters and new lighter wharves, they may convert to spreading moorings.

c. Planning clearance, rehabilitation, and construction in harbor areas not shown in the original layout.

d. Planning for more use of onshore areas later in the operation, after requirements for dispersion lessen.

CIVILIAN LABOR

Civilian labor is fairly efficient. Civilian labor reduces the need for engineer units and speeds up construction. In developed areas, rehabilitation may use local engineers, contractors, and superintendents with their normal organization of skilled workers. In many undeveloped areas, local businessmen have organizations that employ and supervise labor in agricultural and other pursuits. They can provide labor skilled in primitive construction methods. In either kind of area, engineers should consider housing, transportation, local customs, language difficulties, and race or religious complications. Engineers adapt construction plans to the methods and materials available. Local civilian labor lowers mobilization and demobilization costs because of the lower wage-scale and standard of living provided in work camps.

Section II. Layout

LENGTHS, WIDTHS, AND WATER DEPTHS

World War II ships provide models for current Army requirements. They provide lengths and drafts of cargo ships. They also determine standards for water depths and wharf widths for deep-draft and lighterage wharves. These standards are not sufficient for U.S. Merchant Marine container ships expected in future military operations. The following requirements are based on the larger high-speed ships of the U.S. Merchant Marine container fleet.

a. Single-length wharf. A deep-draft wharf should satisfy the following requirements--

(1) The face of the wharf should be as long as the ship, usually between 750 and 1,000 feet. However, wharf length can match the length between the forward and stern hatches of the ship. This shorter length requires mooring lines beyond the ends of the wharf (Figure 6-1, page 6-4).

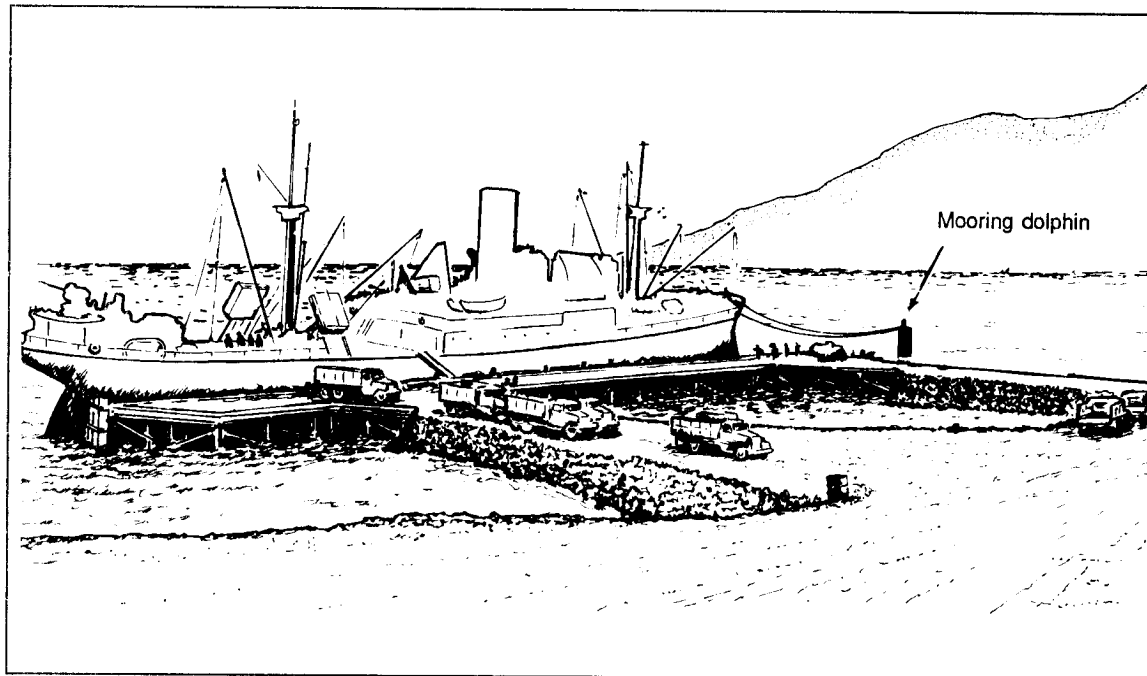

Figure 6-1. Mooring Lines Beyond the Ends of the Wharf

(2) A channel depth of at least 40 feet. This accommodates a fully loaded high-speed container ship.

(3) A minimum wharf deck width of 80 feet. This prevents congestion while loading and unloading containers.

b. Multiple-length wharf. A deep-draft wharf can berth one container ship for each 1,000 feet of wharf length facing deep water. Each 100 feet of wharf left over, facing any depth of water, can serve as a berth for lighters.

DISTANCE FROM SHORE TO WATER OF ADEQUATE DEPTH

a. Break-bulk cargo wharves.

(1) A quay is the easiest wharf to construct for a beach sloping steeply to a depth of 30 feet or more.

(2) Narrow, marginal wharves or floating wharves may be the only practical choices where deep water close offshore makes pile-driving impractical.

(3) A marginal wharf with approaches is best where a gentle beach slope continues uniformly to depths beyond the reach of piles.

(4) A pier is practical where depths range from 30 feet to the maximum depth for pile driving.

(5) Adequate depth near an existing seawall may make a marginal pile quay in front of the seawall the best solution (Figure 6-2). Only limited dredging is practical after wharves are built. Heavy dredging causes caving, which breaks wood piles.

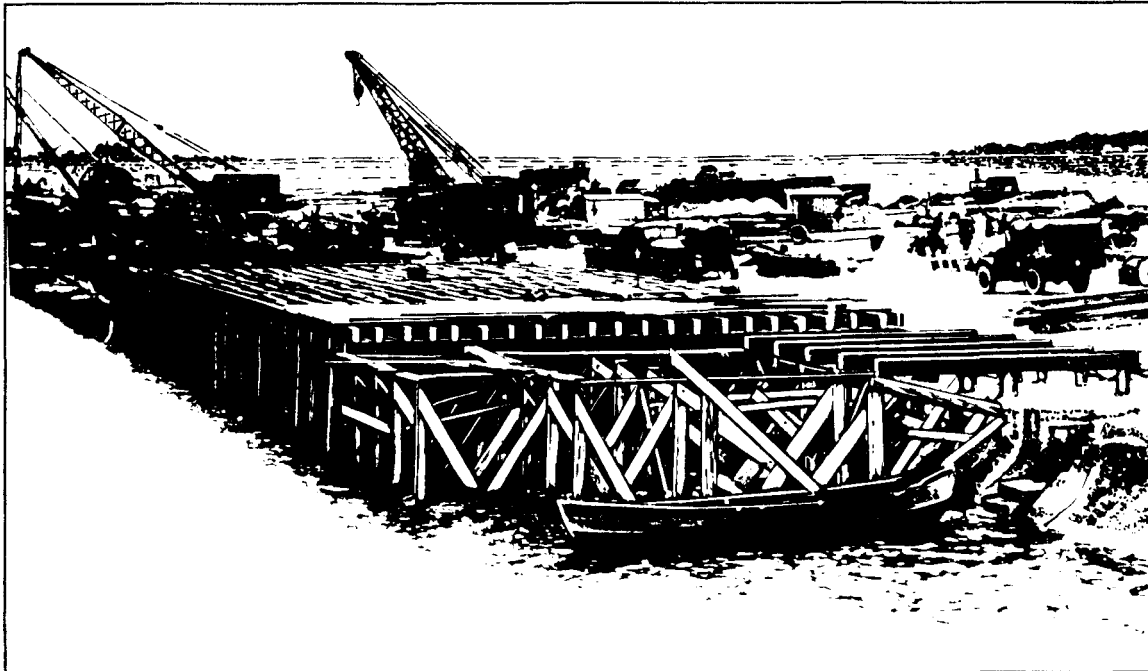

Figure 6-2. Quay in Front of Existing Seawall

b. Expedient container wharves. The wharves described above are not suitable for containers. The most promising design for expedient military container ports uses self-elevating, spud-type barge piers to construct finger-pier wharves. This design allows container wharves in water deeper than 50 feet to raise and lower. Wharves move up to 50 feet per hour can accommodate tides or dredging.

Section III. Methods of Location

BULKHEAD AND PIERHEAD LIMIT LINES

In the navigable waters of the United States and its possessions, the Corps of Engineers determines bulkhead and pierhead limit lines. It sets bulkhead and pierhead lines based on hydrology and navigation. These lines are fixed in all major harbors. Other maritime nations have similar regulatory bodies. No deviations from these lines are authorized. In undeveloped areas, assault units study tides and currents in harbors to locate channels, anchorages, and areas for wharves. Construction units follow up this work, determining limit lines and promulgating data among the agencies concerned.

EFFECTS OF STRUCTURES ON CURRENTS AND SILTING

Any structure extending into a harbor affects the tidal prism, currents, and sediment transport and deposit. Long-shore, wind, river, or permanent great currents may act together or individually to affect scour or sedimentation. Pile and spud-type barge wharves have less effect on currents and silting than do solid-fill quays. However, their effects are similar and could be more damaging to navigation. For instance, sedimentation around pile and spud-type barge wharves could damage the structure during its removal. Damage is worse if bottom materials are unstable and prone to caving or sluffing. This instability makes currents and silting very important factors when building expediently constructed military container ports using spud-type barges or similar methods.

TRANSPARENT TEMPLATES AND TERRAIN MODELS

a. Transparent templates. Special information needed for construction planning is shown on transparent charts of harbors. These charts record all available hydrographic information. They include the bulkhead and pierhead limit lines and emphasize the minimum depth contour for deep-draft wharves. They also show the contour below which depth pile driving is impractical. They show bottom characteristics important in dredging or filling operations. They also show locations of onshore road and rail connections and of in-transit storage areas and utilities. Engineers prepare transparent templates of possible wharf layouts at the scale of the chart. They fit them in place in various arrangements. Engineers then study and compare resulting layouts to determine practicality. They consider the materials and effort available, the best construction phasing, and the facilities available after each phase. They also consider possible interference between construction and operation, and any other matters which affect decisions. They then prepare a final layout showing the proposed construction by phase and priority.

b. Terrain models. Transparent templates help in the initial development of wharf layouts. First, a particular area is tentatively selected, then a three-dimensional terrain model provides the additional information needed for final planning.

(1) The contours of a large-scale, possibly enlarged, topographic map serve as a guide for cutting successive layers (elevations) of urethane. The desired scale determines the thickness of the layers.

(2) The urethane layers are glued together using a sheet of plywood as a base.

(3) Land areas are painted brown, bodies of water blue.

(4) Facilities are placed on the model according to the initial layout on the transparent templates. They are then changed according to dictation.

WORK-HOURS, MATERIALS, AND EQUIPMENT

a. Current methods.

(1) General. Comparative studies of personnel, materials, and equipment, follow this pattern:

- * At theater level, engineers compare the materials and effort required to construct or rehabilitate facilities at the various ports. Planners then choose the best, based on development and theater priorities.

- * At theater Army or base-development level, engineers compare types and locations of facilities within a port.

- * At engineer group and battalion levels, engineers compare construction methods and materials.

(2) Planning. FM 101-10-2 gives factors, materials, and personnel requirements for overall planning and estimating of general and break-bulk cargo port construction.

(3) Detailed estimates. Detailed time-work studies are based on--

- * Job records of troop units for similar projects.

- * Job records of the available major and local contractors. These records show the level of personnel training, experience, and productivity required.

- * Work-output data from manuals or civilian engineering handbooks from unit libraries. Allowances are made for such factors as darkness, weather, delay in delivery of construction material, and inexperienced operating personnel.

b. Future methods. Most military ports of the future will be expedient container ports. They will accommodate fully-loaded 20- to 40-foot, 44,800- to 67,200-pound containers. Current recommendations are to build them with large, prefabricated, spud-type barge piers, which are capable of rapid erection, disassembly, and relocation. These capabilities should reduce the work-hours, material, and equipment needed to build and rehabilitate military ports.

SCHEDULING OF CONSTRUCTION AND EXPANSION PHASES

a. Current methods.

(1) Construction schedules. Engineers frame construction schedules to show, in detail and sequence, the time planned for all operations. They tabulate equipment, work-hours, and personnel for each principal operation. The construction schedule is based on--

- * Time allowed for completion.

- * Equipment available.

- * Type of labor available: regular troop units, reserve troop units, prisoners of war, local contractors, or international contractors.

- * Planned delivery of construction materials.

- * Logical sequence of operations.
- * Necessary delays between operations.
- * Weather.

(2) Time schedules. Planners set time schedules for construction and use that allows for easy port operation and later expansion.

(3) Network analysis. Engineers may use network analyses, such as Critical Path Method (CPM) and Program Evaluation and Review Techniques (PERT). These ensure complete planning and increase confidence in schedules.

(4) Port construction phases. Current procedures for port construction in undeveloped areas fall into three phases:

- * Phase 1--Preliminary. This phase includes all requirements from the arrival of construction units to the beginning of construction of deep-draft wharves.

- * Phase 2--Initial construction. This phase continues to the point when the first cargo ship berth is fully operational. It includes road and rail connections, water supply, electric illumination, and bulk POL facilities which receive liquid fuels directly from tankers.

- * Phase 3--Completion. This phase ends when all authorized facilities are fully operational.

b. Future methods. Designs for future military port construction use large, prefabricated, spud-type, barge/pier components which can be elevated. This capability simplifies planning to get the components to the job site.

Section IV. Dimensions and Approaches

MINIMUM LENGTHS, WIDTHS, AND APRONS

a. Current U.S. Army recommendations are that military expedient container port wharves be 80 feet wide by 900 feet long. An upper width limit of 90 feet is enough.

b. No container wharf will have covered sheds. Existing wharves with covered sheds were built to accommodate noncontainer cargo ships that do not require a full 60-foot wharf apron for working space. This working space has a minimum width of 40 feet.

WIDTH OF SLIPS

a. Current guidelines. Current pier layouts show a minimum 250-foot width of slip between piers, each accommodating one ship. This figure is about four times the beam of the average cargo ship. For piers accommodating more than one ship in length, the minimum is 300 feet. Berthing of ships is quicker and safer if slips between double-length piers are widened to about 500 feet.

b. Projected guidelines. Most container ships of the future will have beams of 100 feet or more. This means that the width of slip between piers will be at least 400 feet to accommodate only one ship length. However, future military ports will have mostly single finger-piers constructed with self-elevating, spud-type barge units. Slips will be uncommon.

WIDTH OF APPROACHES TO OFFSHORE WHARVES

a. Current break-bulk cargo wharves. In effect, an approach is a bridge from the road on shore to the deck of an offshore wharf. The width requirement is the same as for bridges: a minimum of 14 feet between curbs for one-lane; 24 feet for two-lanes.

b. Future container wharves. Recommended Army designs specify causeways (approaches) of expediently constructed container wharves with 60- by 150-foot units for 4-lane traffic. This traffic is conducive to military container handling.

APPROACH FLARES TO MARGINAL WHARVES

a. Current break-bulk cargo marginal wharves. An approach flare in the triangular area between the approach and the inshore edge(s) of the wharf deck can provide turning space. Vehicles arriving on or leaving a marginal wharf need a 90-degree turning space. The approach is built at a 45-degree angle. It has a length of three pile bents along the approach or, a minimum of about 35 feet inside the curb, as measured along the approach.

b. Future container wharves. Most future container wharves will be finger-piers, not marginal wharves. The 60-foot width proposed for future container ports, however, is sufficient for a marginal wharf approach. It would require no approach flares for turning vehicles.

APPROACHES TO SINGLE-LENGTH, BREAK-BULK CARGO WHARVES

Engineers may build a marginal wharf for one ship with a one-lane approach at each end. This arrangement permits more efficient wharf operation than the single two-lane approach to a T-wharf. The unloading of lighters on the inshore face of a wharf built for discharge on one side only is inefficient. If necessary, the wharf can be widened for two-sided discharge. In this case, a draw-span for access of barges and small ships to the inshore face can be constructed in one or both approaches to a U-type wharf. If desired, engineers can design new approaches to a container wharf.

APPROACHES TO MULTIPLE-LENGTH WHARVES

a. Current break-bulk cargo wharves. An offshore marginal wharf long enough for two or more cargo ships normally has a one-lane approach at each end and two-lane approaches at intervals of 500 feet in its length. This arrangement permits a separate circuit of one-way traffic past each ship. Additionally, the approaches improve the transverse stability of the wharf.

b. Future container wharves. Multiple-length container wharves are unlikely in future military construction. However, they could be constructed with the following components for current military container port designs:

- (1) 80- by 300-foot barge piers to construct the wharf.
- (2) 60- by 150-foot barge piers as approaches at each end and at 1,000-foot intervals.
- (3) Cranes to off-load from one side only, not both.

CHAPTER 7

EARTH-FILL WHARF STRUCTURES

GENERAL

a. Types of structures. Earth-fill wharf structures differ greatly in size. They may be small, backfilled bulkheads used at the shore ends or the approaches of pile wharves, or they may be large, square-type filled quays. All wharf structures require some type of bulkhead or retaining wall to hold the fill. A quay also needs a vertical face with adequate water depth alongside.

b. Types of bulkheads or quay walls.

(1) Bulkheads for the shore ends of pile wharves or their approaches use planks supported by round piles or braced by batter piles. They need not be higher than approximately 5 feet above high water. Excessive pressure problems are unusual here.

(2) Quay walls for deep-draft ships may involve a fill of 50 feet plus the tide range. Such a structure may feel great earth pressure. It requires careful investigation and design.

(3) Structures for intermediate depths include wharves for lighterage and those along the edge of a tidal flat. These efficient structures are easy to construct. Typical examples are described in this manual. They include masonry walls, sheet pile bulkheads, and expedient structures such as rock-fill timber cribs, rock-fill barges, or sunken and anchored pontoon structures.

c. Advantages. Earth-fill structures can be constructed quickly. A permanent structure has a load-carrying capacity equal to that of a road or airfield.

d. Disadvantages. Earth-fill structures must be kept within the bulkhead limit. They also affect the tidal prism and require careful bottom investigation and structural design.

MOLES AND BREAKWATERS

a. Moles. A masonry mole may be widened by anchoring a bulkhead to it at some distance from its protected face. Engineers can fill and surface the space between the mole and bulkhead.

b. Breakwaters. Engineers may widen a rock-mound breakwater to use as a wharf. First, they install a bulkhead inshore from the protected face. Then they fill the spaces between breakwater and bulkhead, and between the surfacing material and fill at the top of the breakwater.

MASONRY QUAY WALLS

Masonry quay walls are usually designed as massive gravity-type retaining walls. But the construction time, preparation, and materials normally preclude new masonry in the TO. Engineers repair existing quay walls with reinforced concrete, masonry, or concrete and masonry combined with an epoxy resin mixture. Expedient methods such as sandbags or timber construction serve for temporary construction. The fill and surfacing of the quay is then replaced.

SHEET PILE BULKHEAD

a. Materials. Treated timber may be used when useful life expectancy is low. But wood piles are unsatisfactory below the permanent wet line or where marine borers are active. Wood sheet piles are satisfactory only for shallow depths. When steel is justified, it is protected above a level of about 3 feet below mean low water with bituminous coatings on concrete jackets. The tight joints between steel sheet piles make them the most widely-used type of sheet pile. This fact will remain true in TO construction. Figure 7-1 shows a bulkhead constructed with steel sheet piles and steel tie-rods. Concrete may play a role in future pile construction.

b. Earth pressures. A problem in building sheet pile bulkhead quays is the pressure created by the fill on the bulkhead. Earth pressures vary due to the physical properties of soils. Engineers must make thorough surveys and soil examinations of proposed sites. They must establish accurate bottom and onshore contours and study the geology of the area. They must sample soil layers from the surface to underlying rock or to depths where conditions could not affect the structure. They must consider cohesive soils such as clays and silts as bottom materials or deposits of hydraulic fill. Such soils can act as liquids in transmitting vertical loads as horizontal pressures. Excessive loads may be produced by even a thin layer of soft mud near the bottom of the bulkhead. Engineers should not attempt construction where the bottom includes soft material 5 feet or more deep. They must first remove the soft material and replace it with granular material. Building bulkhead quays is satisfactory if all the materials involved are cohesionless sand or similar soil.

c. Reducing pressures.

(1) The soft mud over the area is dredged and wasted. A sand blanket is put down before driving the piles. Sand improves resistance against outward movement of the piles and reduces earth pressure against the piles. Using sand as the entire fill causes little settlement.

(2) A bulkhead is driven into firm strata and backfilled with soft, unstable mud that causes heavy pressures. Stability of the bulkhead increases if a sand dike is placed behind the bulkhead before the hydraulic fill.

d. Methods of increasing stability.

(1) Driving sheet piles to strata which restrain the lower ends of the piles reduces bending moment. It also allows for scouring and overdredging.

(2) Installing a second wale and set of ties at a lower level improves the stability of bulkheads. This underwater work occurs only when more stability is absolutely necessary.



Figure 7-1. Bulkhead Using Steel Sheet Piles and Tie-Rods

e. Bulkhead anchorage. Wales can be a pair of channels or I-beams welded to the sheet piles just above mean low water. These are tied to anchors by steel rods tightened with turnbuckles. The anchorage must be a stable formation above the waterline, such as buried deadmen or a pair of steel sheet piles. The point of anchorage may also be below the waterline. Each anchor consists of a pair of bearing-type piles capped by a heavy timber or a reinforced concrete beam. These anchorages must not be closer to the bulkhead than 2 to 3 times the depth from msl to the dredged bottom. Wales and tie-rods are protected with a heavy coating of rust-preventive bituminous material. This coating protects them within a zone about 6 feet inboard of the bulkhead. Back of this zone, heavy corrosion is unlikely except in acid soils or cinders.

f. Importance of the construction sequence.

(1) Dredging of soft material must precede pile driving. But dredging in front of the bulkhead increases the water depth after the fill has been placed and compacted. The lateral load at this time is heavier than at any other time. Material in front of the bulkhead should help stabilize it during backfill. Dredging must occur in several successive cuts to avoid rapid load changes.

(2) Tie-rods are prestressed lightly but uniformly before backfilling. This prevents uneven alignment of the bulkhead under full load. Normally, a turnbuckle is located near the center of each tie-rod. The tie-rod is supported on a pile near the turnbuckle to avoid increased tension as the fill compacts.

(3) Placing fill before backfilling improves the stability of pile anchors.

(4) Except as described under (3), all backfilling is away from the sheet piling, not towards it. For example, fill away from the longitudinal center of the bulkhead and toward its end. This avoids trapping water and soft material against the bulkhead.

EARTH FILL FOR QUAYS

a. Fill soils.

(1) Sand, gravel, and other cohesionless materials are most suitable for fill. A slight mix of silt or clay in the cohesionless material is acceptable.

(2) Clay, silt, and mud alone are unsuitable. They may be made usable by mixing sand or gravel with them.

(3) Rock and rubble are good base materials for fill.

b. Dredging operations for fill. Hydraulic dredging is a cheap way to obtain fill. The fill method depends on an analysis of the material obtained in dredging. Use of hydraulic slurry for fill requires--

(1) A retaining bulkhead around the area to receive the fill. Its height depends on the desired finished grade of the filled area and the type of slurry available. Sand compacts very little after the runoff period. However, up to 50 percent reduction in volume may occur with mud.

(2) An area behind the bulkhead large enough to permit material to settle prior to runoff.

(3) Weirs or spillways to control runoff. Runoff from the disposal area carries solids with it. Prepare runoff points to control shoaling.

BASE AND SURFACE FOR QUAYS

Civil engineering textbooks and FM 5-330 give detailed information for building various quay bases and surfaces. Engineers normally install a curb or string-piece at the face of the quay and concrete foundations for mooring hardware. In anchored bulkheads, these are tied to the anchor. The working surface of the quay is pitched to drain into a ditch at the inshore edge of the working area. This ditch normally continues along each end of the quay to the waterline. The pitch of the working surface is 1 percent of impervious surfacings. However, a flatter pitch to an absolute minimum of 0.25 percent works for concrete paving if there is little rainfall.

CHAPTER 8

PILE WHARVES

Section I. Bearing Piles

PURPOSE

Bearing piles carry superimposed loads, transferring them to the ground as one of the following:

- a. End-bearing. A column with the point bearing on rock or firm stratum.
- b. Frictional. A column with resistance between the pile and soil into which it is driven. It transmits the load to the lateral soil. Frictional resistance is called skin friction.

TYPES

- a. Timber piles.
 - (1) Uses. Round timber piles are used as bearing piles for timber wharves, fender piles for wharves, and anchor piles for bulkheads. They are also used in pile piers, clusters, and dolphins. Driven flush in clusters, they increase the bearing value of a structure. Timber piles, available in most areas, are easily cut, capped, fastened, and braced.
 - (2) Characteristics.
 - (a) The standard timber bearing pile is a straight, firm, solid tree trunk with closely trimmed branches. It should be free of sharp bends, large and loose knots, splits, and decay. It should have a reasonably uniform taper. A straight line from the center of the butt to the center of the tip lies entirely within the pile.
 - (b) Tip diameters should be 8 to 11 inches for timbers up to 40 feet long and 6 to 8 inches for longer lengths. The diameters of butts should be 12 to 18 inches for timbers up to 40 feet long and 12 to 20 inches for longer lengths.
 - (3) Life. Timber pile life depends on the species and condition of the wood, pretreatment, and extent of exposure.
 - (a) Creosoted piles generally last 5 to 10 years in water infested with marine borers. Without marine borers, creosoted piles may last 10 to 20 years when alternately wet and dry. They last indefinitely when continually submerged.
 - (b) Untreated piles usually last only 3 to 6 months in tropical waters infested by marine borers. Resistant timber species are greenheart or turpentine.
 - (4) Preparation. The following procedures protect the pile during driving:
 - (a) For hard-driving, remove 2 to 6 inches of the pile butt after treatment. This particular area becomes saturated with creosote, which penetrates the end grain of the wood easily. The removal of this short-end section transmits the energy of the hammer more readily to the lower sections of the pile. The ends should be treated with cold tar pitch.

(b) Proper fit between the butt of the pile and the driving cap of the hammer protects the pile from damage during hard-driving. The butt of the pile must be square-cut and shaped to fit the contour of the driving cap. Shaping the butt of the pile to fit the cap works best when the point of the pile is a little larger than the cap. The wood will be compressed into the driving cap. Both pointed- and flat-plate shoes (Figure 8-1) are used for round timber piling, but flat plates with square-cut tips are easier to keep in line during driving. Pointed tips add little to the rate of penetration when driving piles into subsurfaces.

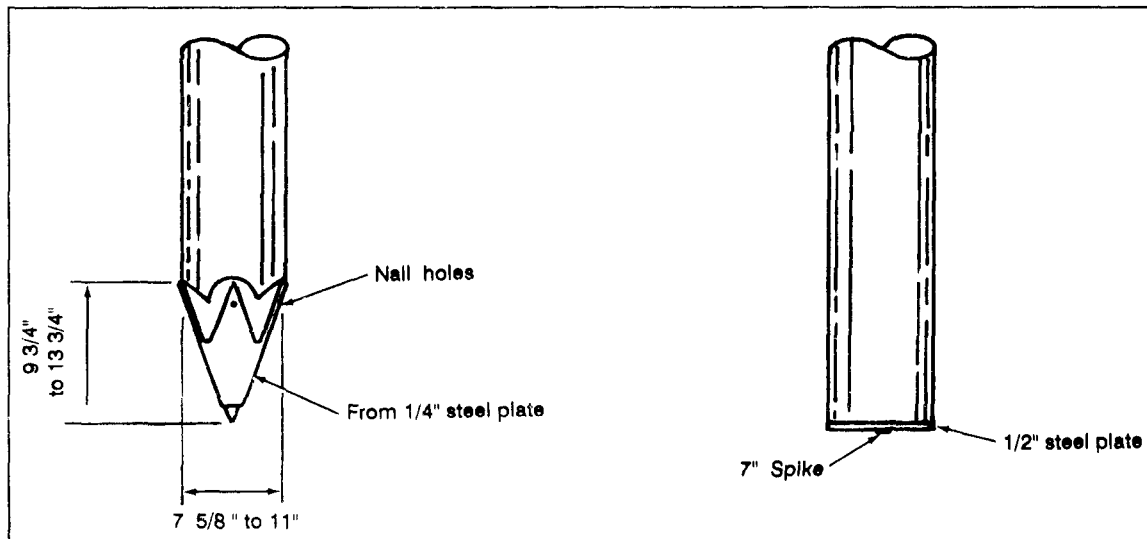

Figure 8-1. Pointed- and Flat-plate Shoes

(c) If no driving cap is used, or if the pile is crushed or split, the top end of the butt should be beveled and wrapped tightly with 12-gauge steel wire to form a 4-inch band. The wire should be stapled firmly in lace to protect the pile butt during hard-driving. Steel strapping about 1 1/4-inch wide will also provide protection. It should encircle the pile tightly twice, 2 feet from the butt.

b. Steel bearing piles.

(1) Background. In the U.S., steel-pipe piling and steel HP sections (at first H-sections) were used as steel bearing piles because--

- * Their manufacture allows long lengths without great handling weights. Engineers have driven unspliced lengths of 127 feet 6 inches, and spliced lengths of 304 feet.
- * They penetrate rock and hard materials with the least effort and time.
- * Their cross sections are smaller and displace less soil. They are often the only piles that can be driven to the desired penetration without jetting or coring.
- * HP steel piles can be driven below the scour line in sand and gravel.
- * Penetrations of 10 to 12 feet in hardpan and up to 22 feet in cemented sand and gravel are common.
- * HP steel piles can resist large bending moments such as earthquakes.

(2) Commonly used sizes. AFCS designs specify the steel bearing piles most frequently used in military construction. They are the 14-inch HP section steel beam weighing 73 pounds per linear foot, and the 12-inch HP section steel beam weighing 53 pounds per linear foot.

(3) Additional characteristics.

- * Steel pipe lengths can be adjusted by cutting, splicing, or welding.

- * Steel bearing piles are strong, permitting great lengths and accepting great impact. With firm footing and adequate lateral support, steel bearing piles can support heavy loads.

- * Steel bearing piles may be used as friction piles in both compacted or uncompacted sand and gravel.

- * Steel bearing piles drive easily into clay. A plain bearing pile will have static resistance greater than the driving resistance indicates. This means skin friction increases after rest. In medium to stiff clay the pile may compact the soil between flanges during driving. The clay may grip the pile and be carried down with it. This has the same effect as using a wider cross section of pile.

c. Concrete bearing piles.

(1) Background. Past TO construction practices have not used concrete bearing piles much. But improvements in pile driving equipment and in pile manufacture, especially in precast and precast-prestressed concrete piling, have made concrete highly suited to TO construction. Important characteristics of concrete piles are as follows:

(2) Advantages.

- * Concrete piles carry heavy loads through soft materials to firm, hard layers.

- * Concrete piles can be conventionally reinforced and prestressed to resist sizable uplift and bending forces.

- * Concrete is not subject to decay or marine borer attack. When properly positioned, it is the most maintenance-free pile material.

- * Concrete accepts almost any shape or form desired. It is usually formed into rectangular and octagonal cross sections.

- * The large bearing areas of the tips of many types of concrete piles offer an advantage as point-bearing piles.

(3) Disadvantages.

- * Concrete piles have poor resistance to lateral forces.

- * Spalling of concrete from the surface may expose interior steel to rusting. Rust is especially undesirable in prestressed piles.

- * Splicing concrete piles requires cure time.

- * When compared to timber or steel piles, concrete piles require larger pile-driving and handling equipment.

(4) Types.

* **Precast.** Precast concrete piles may be either conventionally reinforced or prestressed. Construction with precast concrete piles specifies precast-prestressed concrete piles. Cross-sections range from 12- by 12-inches to 20- by 20-inches, or equivalent octagonal sections. The 14- by 14-inch cross section (Figure 8-2) is the most common. Problems involved in transporting and handling extremely long members make precast concrete piles longer than 90 to 100 feet uncommon.

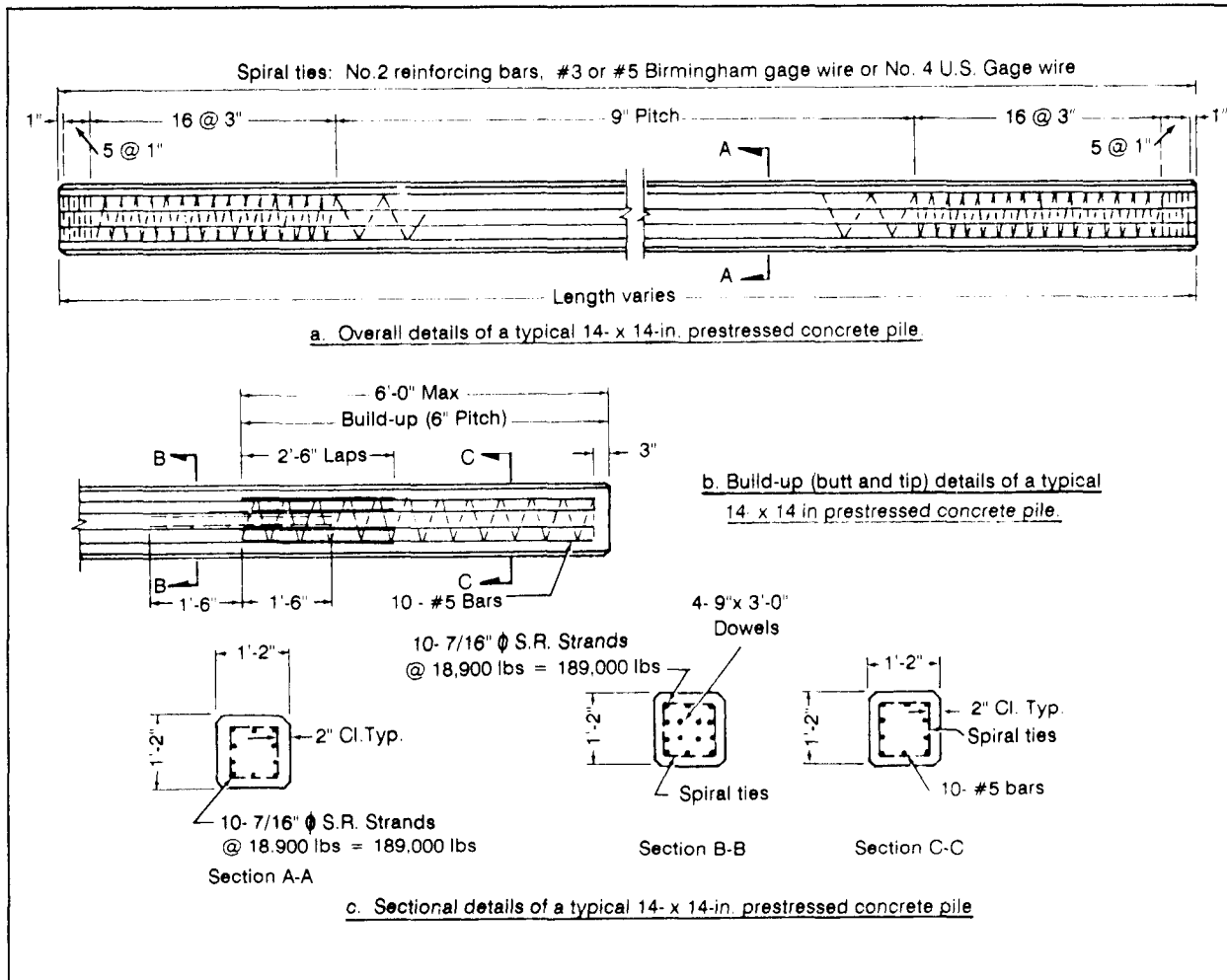

Figure 8-2. Cross Section of a 14- X 14-inch Pile

* **Cast-in-place.** Cast-in-place piles are made within a sheet-metal case. The case may or may not be recovered. Uncased cast-in-place piles are common where foundation materials do not allow soil or water to fall into the hole. Here the hole will not change size because of the compressive actions of the soil. Cast-in-place concrete piles are usually

d. **Composite piles.** Composite piles are formed with a combination of two or more materials. Typical examples are--

- * Timber or steel in lower sections, and cast-in-place concrete in upper sections.
- * Steel pipe piling encasing cast-in-place concrete.
- * Steel HP pile sections encased with concrete.
- * Timber in lower sections with concrete-fill, thin-gauged, corrugated steel shells in the upper sections. Composites have been used commercially. Construction in the TO limits its use to repairing damaged sections.

SHEET PILES

a. Uses. Sheet piles are special interlocking piles of steel, wood, or concrete. They form a continuous wall which resists horizontal pressure from earth and water and are used to:

- * Build cofferdams, which exclude water and earth from an excavation before construction starts.

- * Form braces in trench sheathing.

- * Form small dams.

- * Form cut-off walls beneath water-retaining structures to retard the flow of water.

- * Construct bridge piers.

- * Construct groins and sea walls.

b. Types.

(1) Timber sheet piles. Abundant timber in the TO and a poor supply of steel or concrete allow timber sheet piling for temporary structures. Marine borers and the need for permanent structures make creosoting the timber necessary. Tongue and groove piling of single timbers (Figure 8-3) serves where only earth pressures are involved, such as in excavating a trench above the water table. Larger pressures and work below the water table requires planking (Figure 8-4), wakefields (Figure 8-5), or heavy timber piling (Figure 8-6).

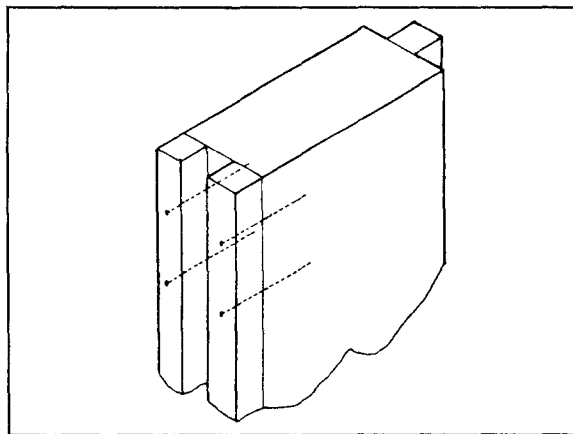

Figure 8-3. Tongue and Groove Piling

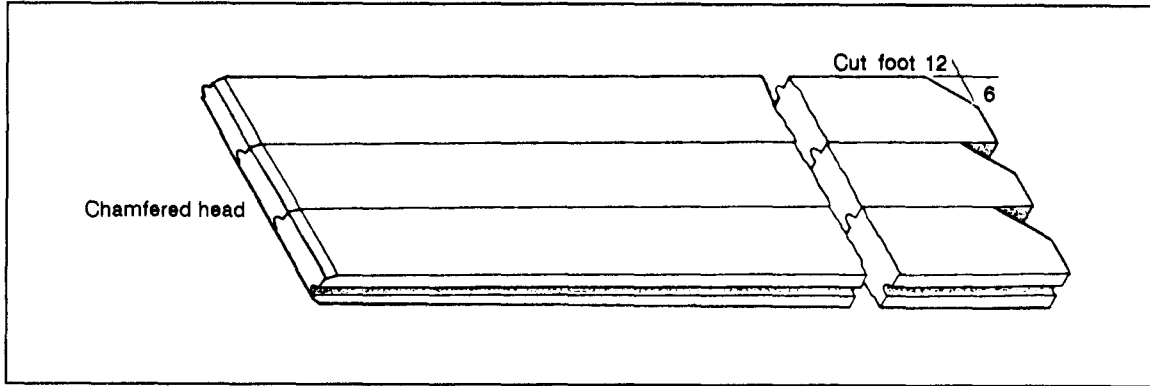

Figure 8-4. Planking

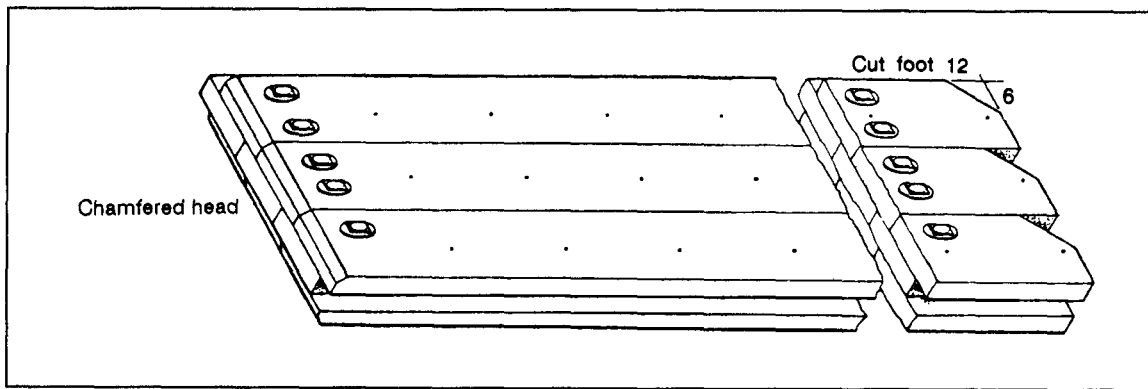

Figure 8-5. Wakefield Piling

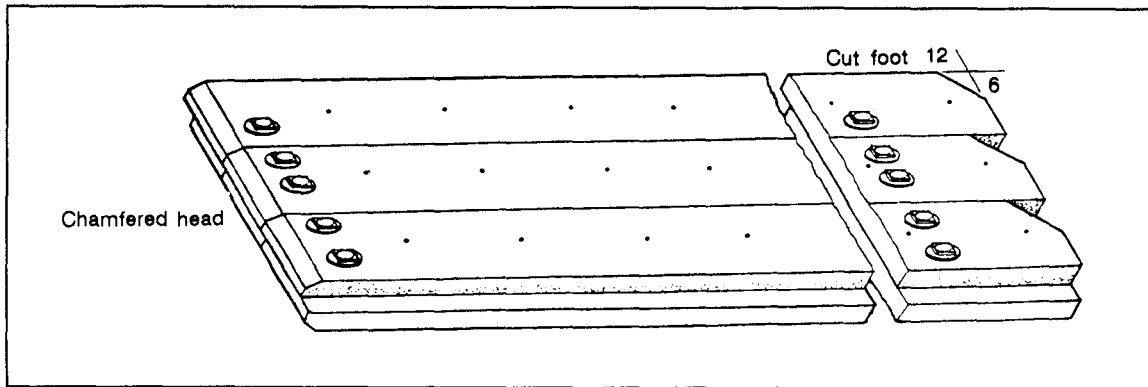

Figure 8-6. Heavy Timber Piling

(2) Steel sheet piles. Steel sheet piling is preferred because--

- * The interlock (Figure 8-7) on each pile edge guides the pile during driving and can transfer tension from pile to pile.
- * Steel sheet piles are strong and easy to drive and align during hard driving.
- * The interlocking edge reduces leakage.
- * They can be recovered easily for reuse.

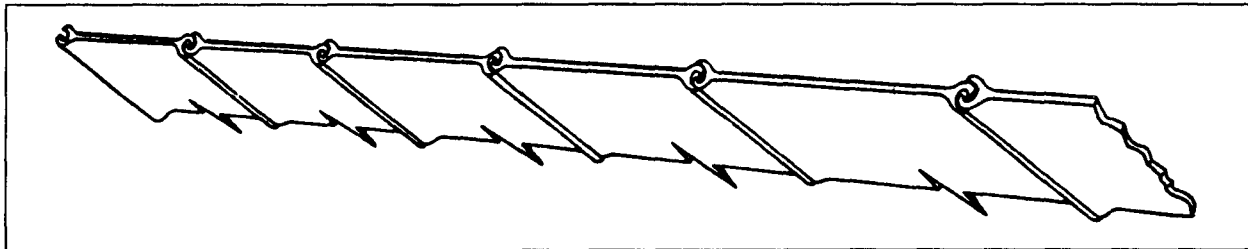

Figure 8-7. Interlocking Piles

(3) Concrete sheet piles. Materials for making concrete are found near most job sites. Concrete sheet piles, nevertheless, are of little use in TO construction. One reason is that pile interlocks cannot transmit tensile forces. Recently, polyethylene interlocks have replaced pile interlocks. Precast-prestressed concrete sheet piles (Figure 8-8, page 8-8) with polyethylene interlocks are capable of transmitting some tensile forces. They also act as a waterstop. Future military construction may adopt this technology since concrete has good structural properties, and it is cheap and widely available.

(4) Composite sheet piles. Composite sheet piling is rarely used. Composite forms include railroad rails and planking (Figure 8-9, page 8-9) and one-half sections of steel sheet piles embedded in prestressed concrete sheet-piling for interlocking.

MARINE BORERS

a. General. Some marine animals destroy unprotected or untreated wooden structures in salt water. Creosoting is an effective protection. A few untreated woods, mostly North American types, appear immune to attack. The following conditions favor rapid development of marine life:

- * The proper degree of salinity.
- * Untreated or unprotected wood between mudline and high waterline.
- * Relatively warm waters.

b. Types of borers. The important organisms in a broad classification are:

(1) Mollusks. The teredo, bankia, lyrodus, martesia, hiata, xylophaga, pholas, lithophaga (lithodomus), and zirphae are bivalves, like oysters and clams.

(2) Crustaceans. The limnoria, chelora, and sphaeroma are crustaceans, like crabs and lobsters.

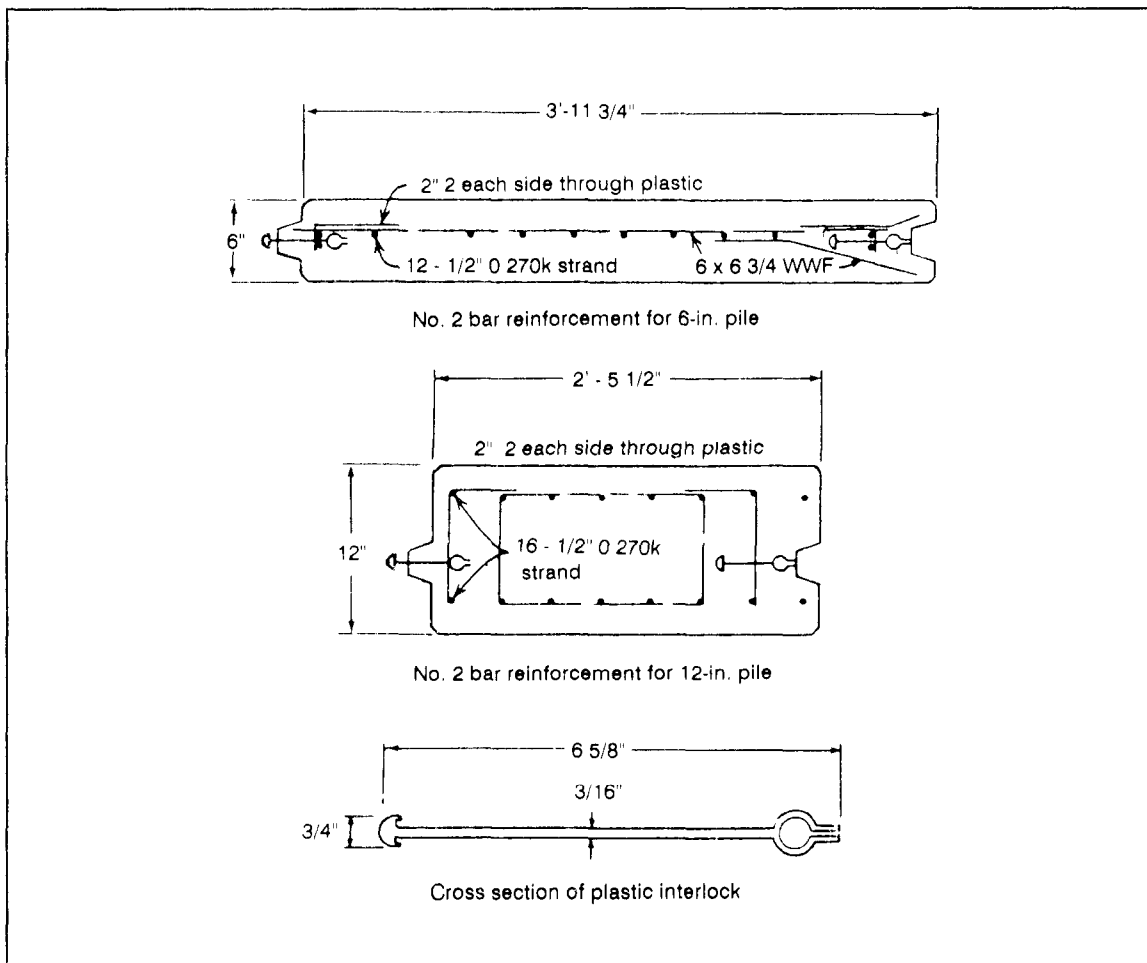

Figure 8-8. Precast-Prestressed Concrete Sheet Piles

c. Methods of attack. The two types of organisms attack differently. Mollusks drill tiny holes in the wood when they are very young. They grow inside these holes, destroying the wood during their growth. Only inspection of the piling's intersurface can detect mollusk attacks. Crustaceans attack the wood surface, reducing pile diameter as they attack. Crustacean attacks are visible. The teredo, martsesia, and limnoria are the most common marine borers.

(1) Teredo. The teredo has a worm-like, slimy gray body with two valves of the shell on the head for boring. During its minute larval stage, the teredo enters the wood. It leaves a tiny hole not larger than a pinhead as the only early sign of infestation. The teredo then tunnels, grows, and lives inside the wood. The interior of the wood becomes a honeycomb of tunnels. In a few months an infested 12-inch pile, which appears sound, may break of its own weight. The teredo prefers warm salt waters. Some have been found in fresh water in India, Australia, and parts of South America. They are active all year in tropical climates. In temperate zones, and even in arctic waters, their numbers may increase suddenly after a rise in water temperatures or salinity.

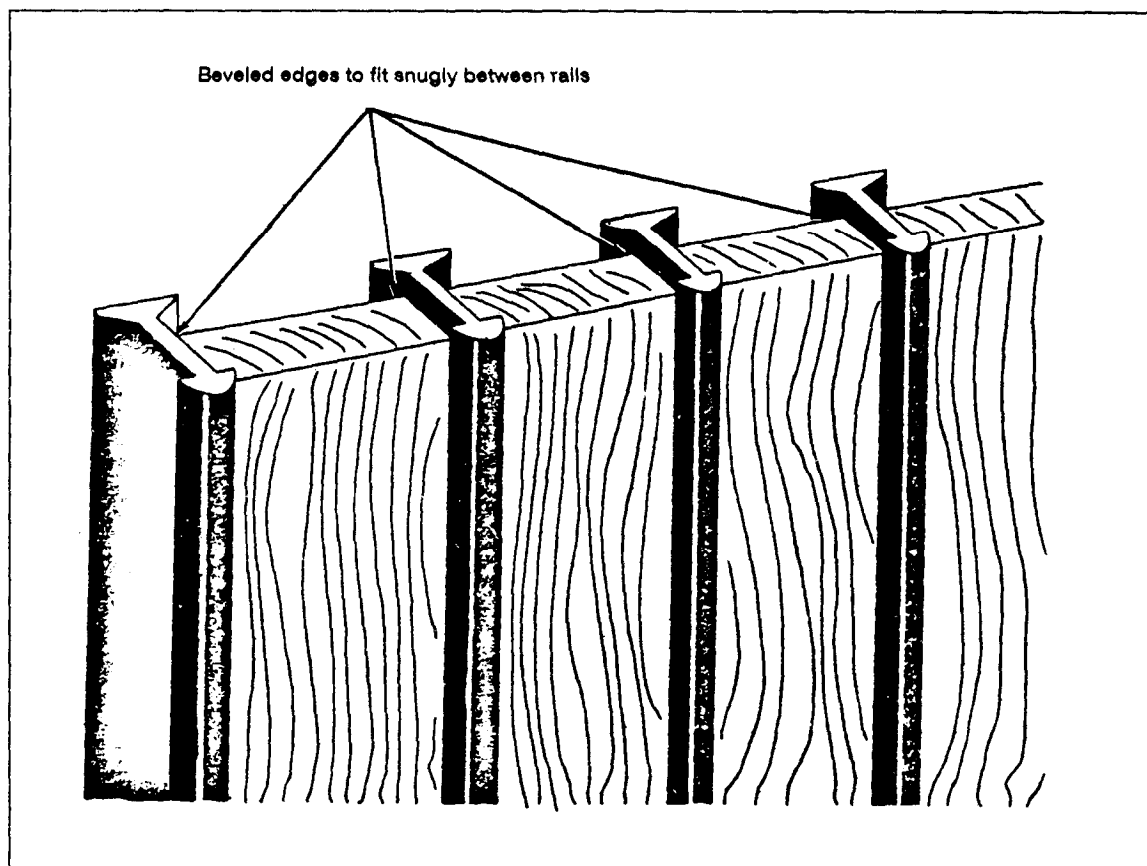

Figure 8-9. Railroad Rails and Planking

(2) *Martesia*. The *martesia* resembles a clam. Its shell encloses its body entirely. It grows to 2 inches in length and $\frac{3}{4}$ inch in diameter. It is highly destructive. Wood disintegrates rapidly under heavy attack. Pile diameter may diminish by 4 inches in a year. *Martesia* areas are Hawaii, the Philippines, and the Gulf of Mexico.

(3) *Limnoria*. The *limnoria* is a tiny distant cousin of the lobster. They destroy piles by gnawing interlacing burrows into the surface, as many as 200 to 300 per square inch. The shallow burrows are 0.05 to 0.025 inch in diameter, seldom over $\frac{3}{4}$ inch long. They follow the softer rings, leaving the surface $\frac{1}{8}$ to $\frac{3}{4}$ inch down a mass of thin walls between burrows that breaks away and exposes a new surface to attack. *Limnoria* can burrow into soft woods such as pine and spruce to a depth of 1 inch a year. The affected wood presents a spongy appearance. *Limnoria* work at all levels from the mudline to high water. They are most active below the low-water line, but may attack at the mudline even at 70-foot depths. Occasionally they attack between tide levels. *Limnoria* avoid hard knots, which are left unavailable. If fill is placed around piles up to the low-water line, attack will begin above that point.

d. Methods of protection against marine borers.

(1) Treatment. Marine borers attack wood to obtain cellulose for food. Poisoning is the best protection. Typical treatments are--

* Creosote. Saturating the surface of the wood with creosote is the most common protection against borers. Absorption varies with type of wood, shape of the piece being treated, and intensity of the treatment. From 10 to 24 pounds of creosote per cubic foot of wood are used. All timber piles are creosoted for use in waters where marine borers are active. Thorough creosoting may extend the life of a pile to 20 years or more. Untreated, the wood lasts only a few months. The effectiveness depends on keeping the treated surface unbroken. Do not use timber hooks or pike poles on treated timbers. The surface may need to be punctured or cut when dapping to apply a brace. Protection is restored by adding two or more coats of creosote oil mopped on at temperatures ranging from 175° to 200°C. Creosote is caustic to humans.

* Other chemicals. Copper, sulphate, zinc, and various bituminous and/or asphalt paints are poisonous to borers. These chemicals are, to some degree, soluble in water and can leach out, losing their protective effect.

* Salt/pressure treatment.

(2) Armoring. Successful armoring includes--

* Steel, iron, verified pipe, and concrete cylinder casings.

* Riprap around piling areas to reduce the oxygen content of the water.

* Bark left on the pile as protection against borers. However, bark reduces the bearing capacity of most timber piles.

* Steel and other metal sheathings. Metal must be free of tiny holes.

PILE CAPACITY

a. Bearing pile loads. Bearing piles transmit these superimposed loads to the ground:

* Vertical loads from wharves and vehicles.

* Lateral loads from wind, waves, current, movement of vehicles on the wharf, or the pull of ships at wharf moorings.

b. Capacity calculation. The safe carrying capacity of a bearing pile depends on its ability to transmit the imposed load to the ground. It does this by either skin friction between the pile and the surrounding soil, or by direct bearing on underlying firm strata. Pile capacity depends on the physical properties of the subsurface soils. Piles for semipermanent wharf structures in the TO are usually limited to the loads in Table 8-1.

Table 8-1. Maximum Allowable Loads Per Pile

Diameter* (inches)	Timber (tons)	Concrete (tons)	Steel Friction (tons)
8	16	---	20
10	24	30	30
12	30	36	36
14	36	42	42
16	42	48	---

* Measure the diameter of a timber pile at a point 1/3 the length of the pile from the butt.

PILE BENTS

A pile bent is a support consisting of a single transverse row of bearing piles connected by transverse bracing and a cap (Figure 8-10). The distance between supports holding up a structure is called the span. It is usually covered by stringers and decking.

a. Bracing.

(1) **Transverse bracing.** Typically 4- by 8- or 4- by 10-inch timbers applied to add stability to a bent. Transverse bracing is applied diagonally (Figure 8-10). It is fastened to each pile with one 3/4-inch bolt. Its vertical spread is from the low-water line to the lower edge of the cap. Large tide ranges, 15 feet or more, require horizontal bracing at the low-water level.

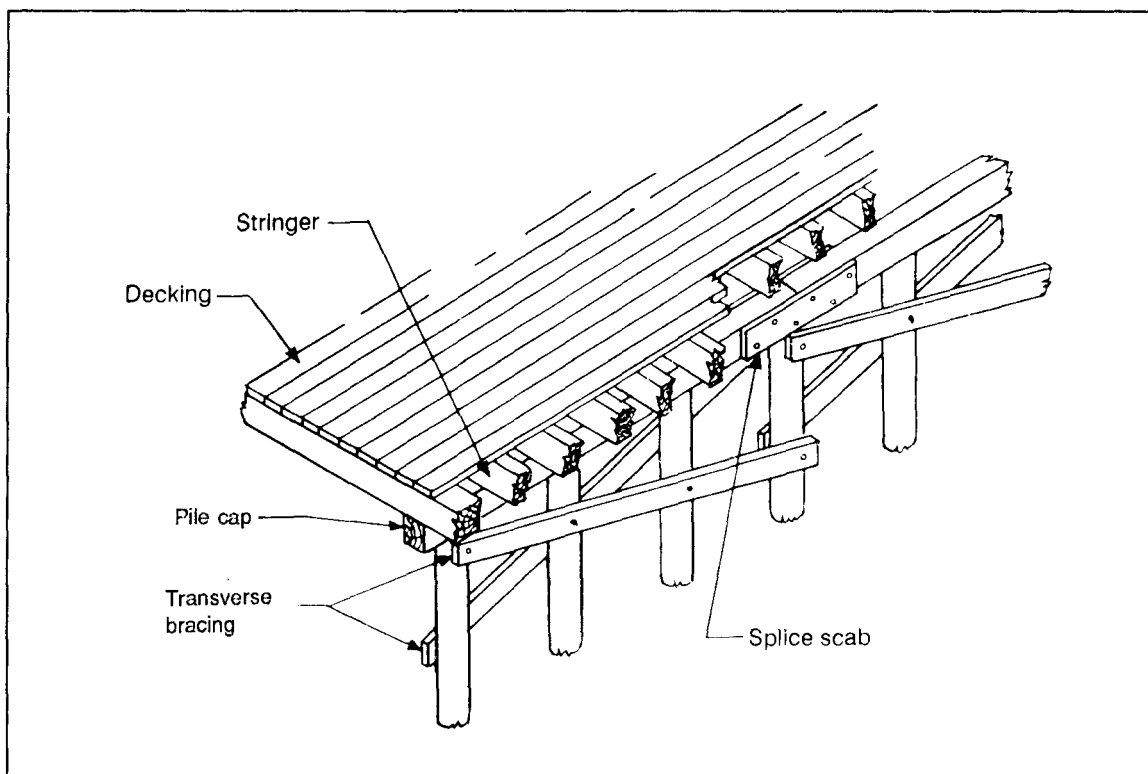

Figure 8-10. Transverse Bracing and Cap

(2) **Longitudinal bracing.** Adds resistance against lateral forces acting on a wharf structure. Figure 8-11, page 8-12, shows both longitudinal and transverse bracing of a wharf under construction. Engineers use longitudinal bracing between bents of offshore marginal wharves and at bollards on other types of wharves. It is also used on wharves having tidal ranges of more than 15 feet. Sometimes engineers also use horizontal bracing with longitudinal bracing between bents at low water level. Figure 8-11 shows transverse, longitudinal, and horizontal bracing for tidal range over 15 feet.

b. **Freezing spray.** Ice formed on the bracing increases the vertical load on a wharf. This increased load must be lessened or eliminated. Figure 8-12, page 8-12, shows wharves constructed in areas of extreme cold. The bracing is concentrated at the center of the structure and omitted on the outer piles.

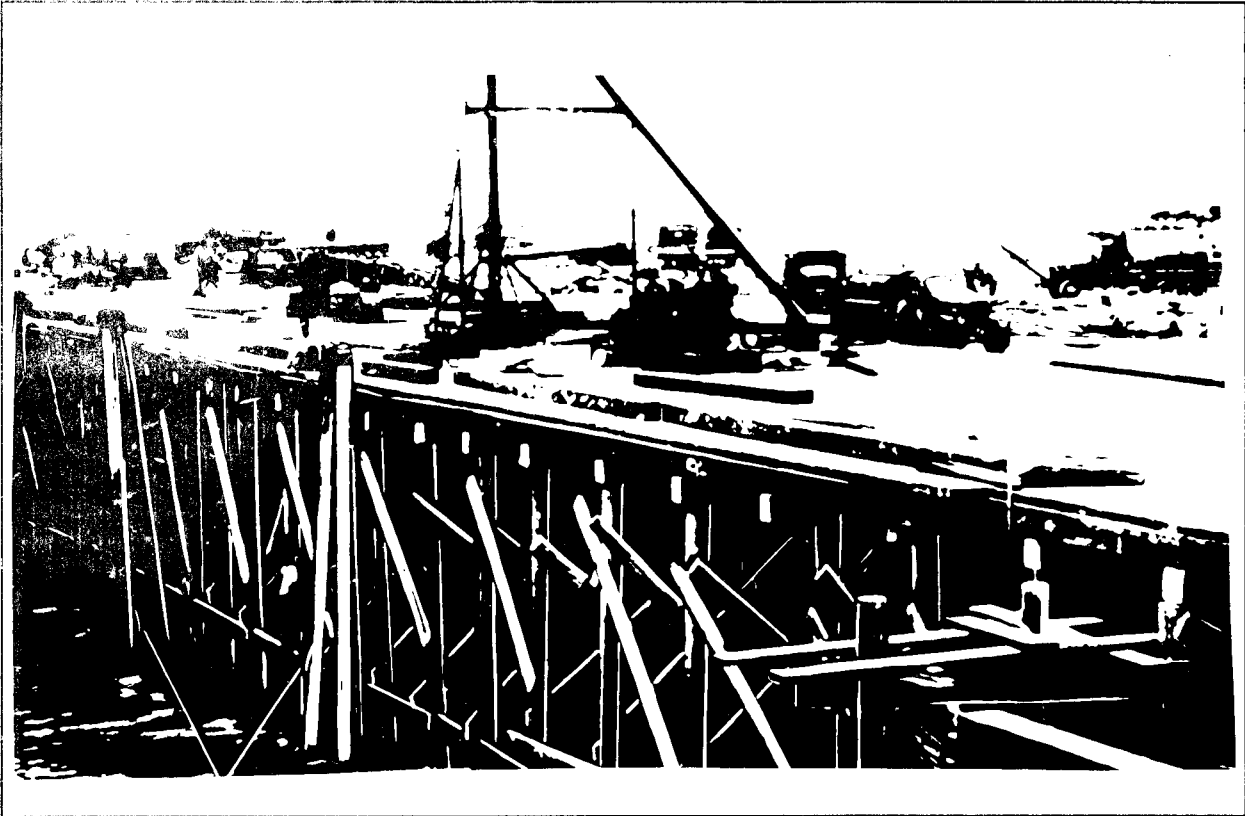

Figure 8-11. Transverse, Longitudinal, and Horizontal Bracing for Extreme Tidal Range

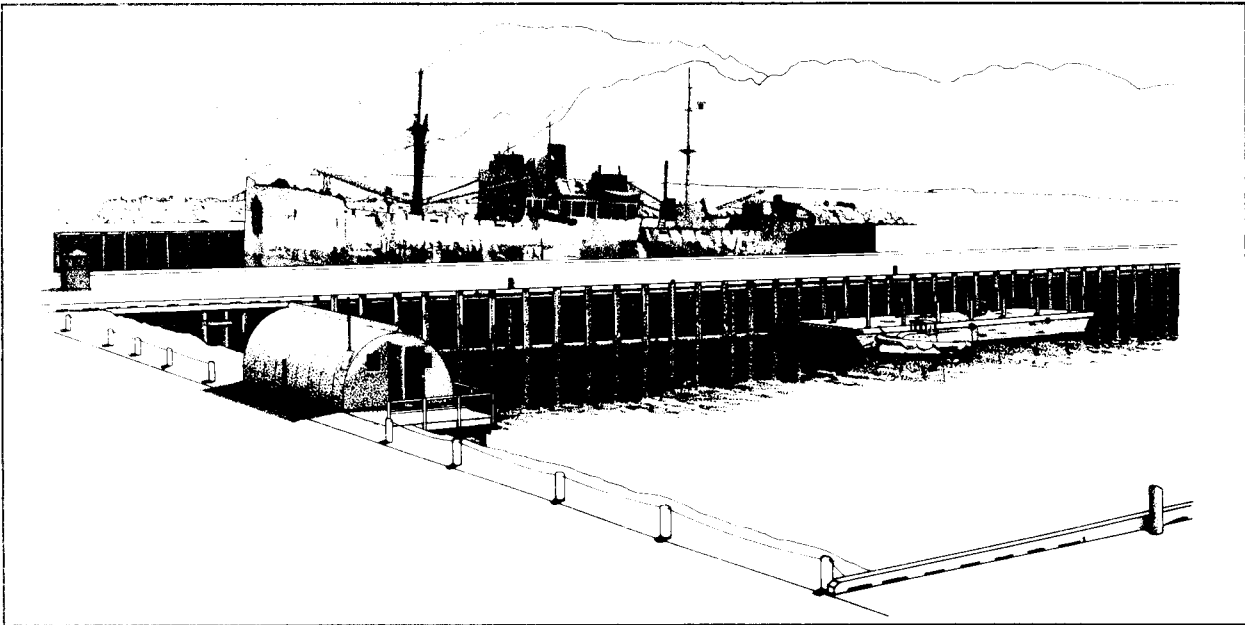

Figure 8-12. Cold Weather Wharf

c. Pile spacing. The bearing capacity of a friction pile in plastic soil results from transmitting the load to a cone of soil surrounding the pile. If piles are driven close together in soft soil, soil cones overlap. When this happens, the bearing capacity of each pile is lessened. Generally 3 feet is the minimum acceptable spacing. Five or more feet between friction piles allows the piles to act independently.

Section II. Timber Pile Wharves

ADVANTAGES AND DISADVANTAGES

a. Advantages.

* **Availability.** Timber is readily available in most locations or can be easily transported from nearby areas.

- * Good friction pile characteristics.
- * Easy to use with TOE equipment.
- * Fast construction.
- * Lower requirements for highly-skilled labor.
- * Cheaper than concrete and steel.
- * Flexible and resistant to impact.

b. Disadvantages in container-port construction.

- * Impractical in container-port construction due to its limited load-capacity.
- * Unavailable in lengths required by container-ports and difficult to splice.
- * Susceptible to fire and marine organisms.
- * Construction too slow for expedient container-ports, which may be needed in less than 90 days.

c. Summary. Timber construction occurs in break-bulk cargo ports and in most military port construction.

STANDARD PLANS. Army standard structural plans are currently under revision. These plans assume that timber pile wharves are suitable for lighters and break-bulk cargo. Plans assume a uniform live-load of 500 pounds per square foot, side pressure of 1,000 pounds per linear foot, and a Cooper's rating of E-50 where railroads are s own. The designs must be changed to handle the greater loads of container ports. Specific wharf designs and corresponding information still contained in Army manuals are--

a. Types of wharves. Plans and bills of materials (see TM 5-303) are given for--

(1) Rehabilitation of Existing Wharves:

(a) Scheme I, rehabilitation of deep-water piers or wharves, 30 by 500 feet, using timber piling, timber decking, and steel trestling.

(b) Scheme II, rehabilitation of deep-water piers or wharves, 20 by 500 feet, using timber piling, timber cribbing, and steel trestling.

(c) Scheme III, rehabilitation of deep-water piers or wharves, 36 by 500 feet, using steel piling, steel trestling, steel framing, and timber decking.

(d) Scheme IV, rehabilitation of deep-water piers, 36 by 500 feet, using timber piling in concrete-pile boots, timber decking, steel trestling, and combinations of timber and steel framing.

(e) Scheme V, rehabilitation of deep-water piers or wharves, 19 by 500 feet, using timber piling, timber decking, concrete beam support in craters and at quays, steel deck framing, and steel trestling.

(f) Rehabilitation of lighterage wharves, 35 by 500 feet, using timber piling in concrete-pile boots, timber decking, and steel rider caps at quays.

(2) New construction:

(a) A 90- by 500-foot pier with a railroad approach trestle.

(b) A 60- by 500-foot wharf with road and railroad approach trestles.

(c) A 35- by 500-foot lighterage wharf.

b. Details for new construction. Standard designs for the 90-by 500-foot pier and the 60-by 500-foot wharf are given for tides of 5, 15, and 25 feet. For a 35- by 500-foot lighterage wharf, the tide range is 10 feet. Depth at mean high water is 20 feet. Deck elevations for piers and 60- by 500-foot wharves are 6 feet above mean high water; for the lighterage wharf, 5 feet. The designs have timber-pile caps, stringers, curbs, and deck. Fender systems consist of timber piles and chocks. They show longitudinal and transverse bracing details for the different tide ranges and locations. They also show wharf hardware installation details.

c. Adaptability of new construction designs. Standard designs for new construction can be modified. Design engineers can change the size and spacing of timbers to give a structure added strength and rigidity. Pile wharf design is similar to bridge design (in FM 5-312). Wharves, however, must resist much higher lateral pressures.

STRINGER LAYOUTS FOR APPROACH FLARES

a. Pile bents used on approaches to offshore marginal wharves are placed parallel to the shore. Thus, pile caps are parallel and stringers are perpendicular to the shore.

b. Placement of pile bents, caps, and stringers of the wharf proper is opposite that of the approach. Therefore, bents and pile caps are perpendicular and stringers are parallel to the shore.

c. Standard 12- by 12-inch timber pile caps may be used. The portion of the pile bent common to both the wharf proper and the approach (Figure 8-13) is cut off 12 inches lower than the tops of the piles in other bents.

d. The following capping arrangement is used for the bent common to the wharf proper and the approach:

(1) A lower cap of 12- by 12-inch timber is placed on top of the common bent piles.

(2) The pile caps of the wharf proper rest on the lower cap.

(3) Filler blocks (false caps) the same size as the pile caps of the wharf proper are placed on the lower cap between the pile caps of the wharf proper.

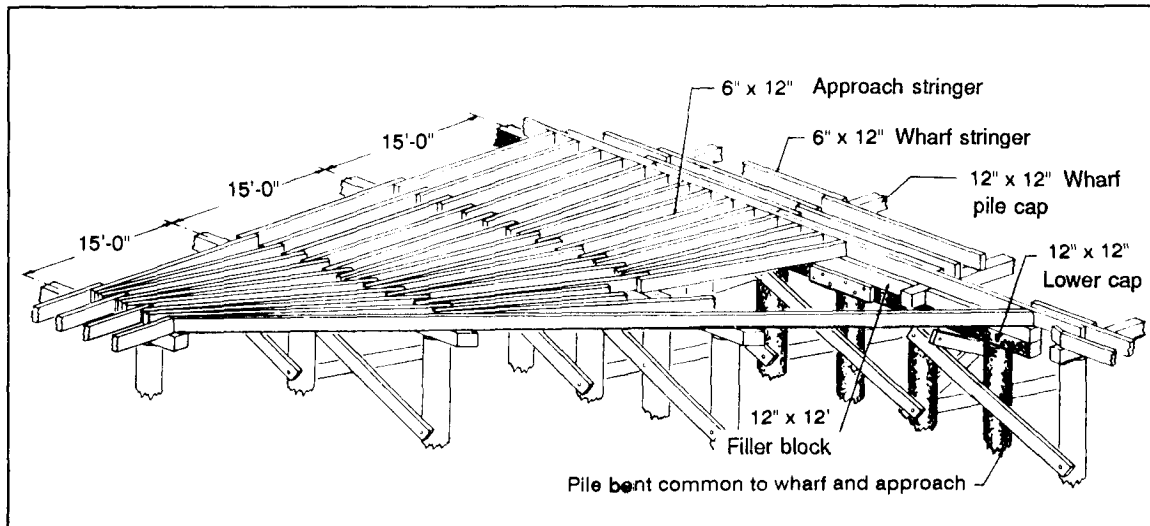

Figure 8-13. Pile Bent Common to the Wharf and the Approach

Section III. Steel and Concrete Pile Wharves

MILITARY AND COMMERCIAL USES

a. Military uses. The Army currently has no standard design for building new steel or concrete pile wharves. Previous manuals did, however, describe the use of steel piling, trestling, bracing, and limited decking in the rehabilitation of existing piers or wharves. Current military design omits steel and concrete in favor of timber because steel and timber both--

- * Require more highly skilled construction personnel.

- * Require more time, especially for cast-in-place concrete which requires time for form work as well as curing.

- * Require more heavy equipment for positioning and placement.

b. Commercial uses. Commercial port designers have specified steel and concrete pile wharves because both--

- * Resist dry rot, marine borers, and termites.

- * Can carry heavy loads, including containerized cargo.

- * Have lower maintenance costs than timber (especially concrete pile wharves).

- * Can be made in any desired shape.

- * Are fire-resistant (especially reinforced concrete). Steel is often encased in concrete for protection from high temperatures.

FUTURE USES

a. Rehabilitation. New commercial ports are built to container port specifications. These specifications include either steel or concrete pile wharf construction. It is cheaper to rehabilitate an existing damaged structure than to build a new one. Future engineer construction units will do steel and concrete pile wharf rehabilitation. Steel fabrication and erection methods are described in FM 5-744.

b. New construction. A 30-man commercial construction crew needs nine months to construct a modern (80 by 1,000 feet) steel or concrete pile wharf. This is based on conventional cast-in-place and on-site erection methods. This time factor, even allowing for larger construction crews, restricts TO construction of steel or concrete pile wharves. Steel and concrete will be limited to new nonconventional constructional methods such as--

(1) Steel wharves or piers. Large self-elevating, self-propelled, spud-type barge pier units. Engineers can place these in service quickly.

(2) Concrete wharves or piers. Commercial port engineers have prepared designs for precast concrete pier piling, caps, decks, and curbs. Their techniques should decrease time for conventional concrete port construction. These precast elements could also speed construction of new military container ports in the TO. Military engineers can use large precast concrete pier modules. The modules are approximately 35 feet wide, 97.5 feet long, and 12 feet deep (Figure 8-14). Engineers can bring them to the TO and float them into position on barges. They can be temporarily elevate with electrical jacks attached to large caissons. Permanent installation will be on piles driven through prepositioned holes. The piles will be attached to the pier module with an epoxy-resin compound.

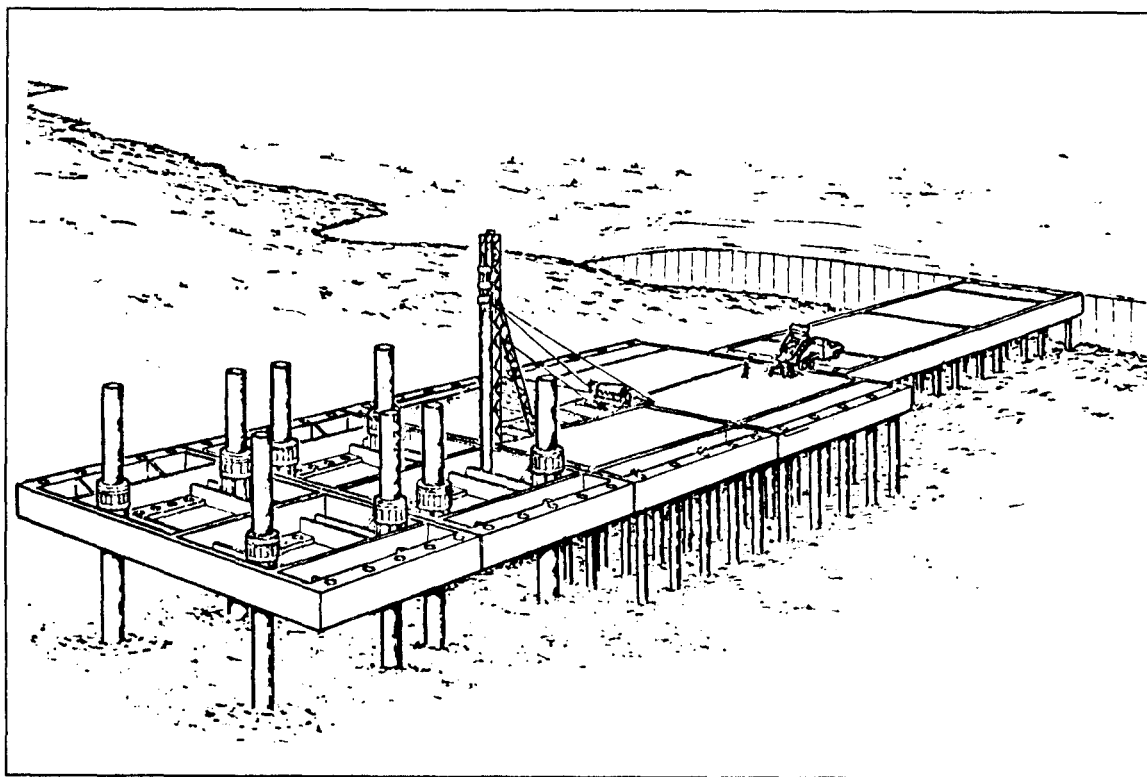

Figure 8-14. Precast Concrete Module

Section IV. Construction of Pile Wharves

The Army (AFCS) currently lacks standard plans for building military container piers. Some construction techniques described in this manual will require modification before use.

STRAIGHTENING, CUTTING, CAPPING, AND BRACING PILES

a. Straightening piles. Engineers should straighten piles as soon as they notice any misalignment during the driving. A pile more than a few inches off plumb needs to be straightened. The rarer the penetration along the wrong line, the more difficult it is to get the pile back into plumb. Check the alignment by lifting the cap from the pile butt. The pile will rebound laterally if it is not properly aligned with the leads and hammer. The following are ways to realign a pile:

(1) Pull it with a block and tackle (Figure 8-15), using the impact of the hammer to jar the pile back into line.

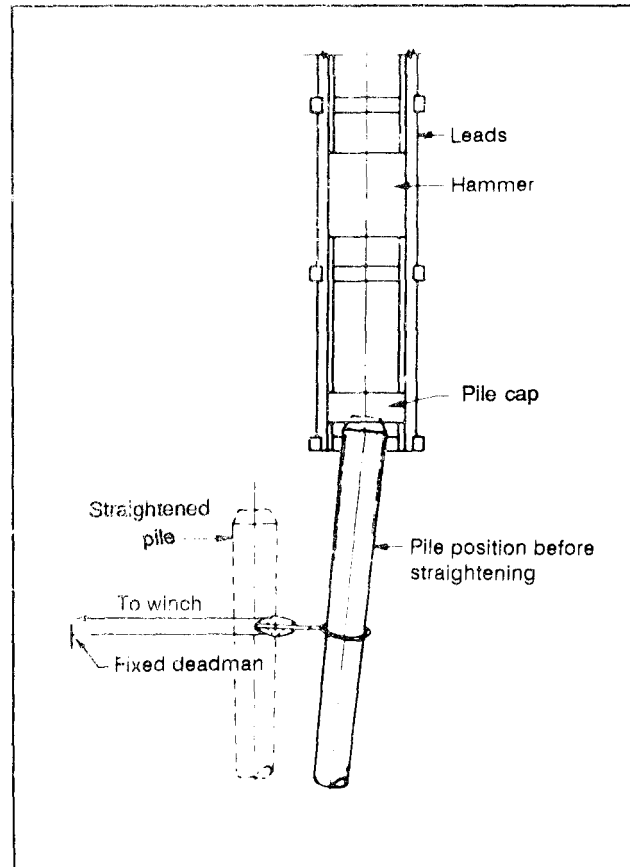

Figure 8-15. Straightening a Pile Using a Block and Tackle

(2) Use a jet (figure 8-16), either alone or with a block and tackle

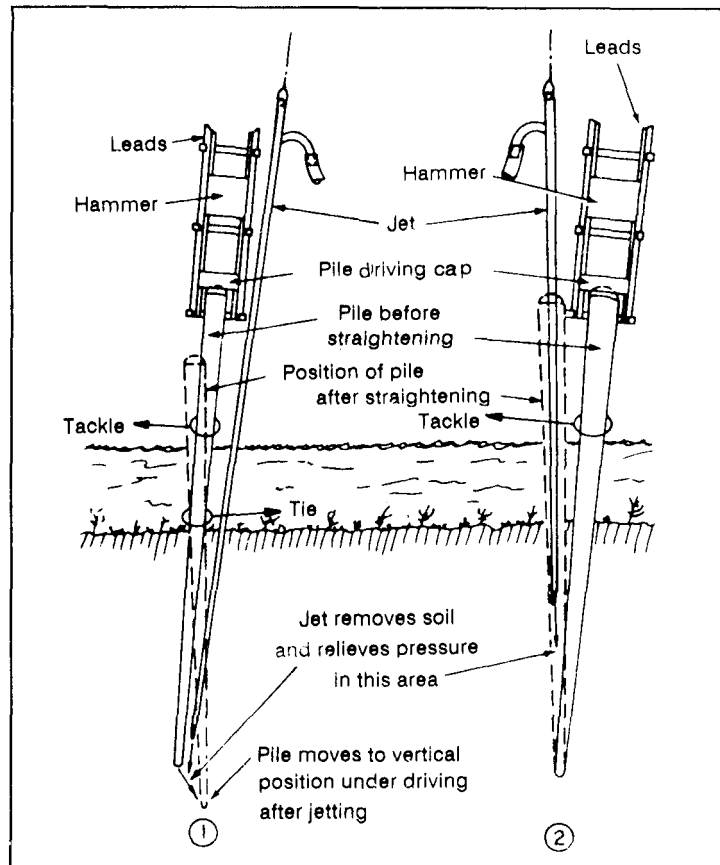

Figure 8-16. Straightening a Pile Using a Jet

(3) Pull it with a tackle and aligning frame (Figure 8-17). The frame may be pulled up when all the piles in the bent are driven.

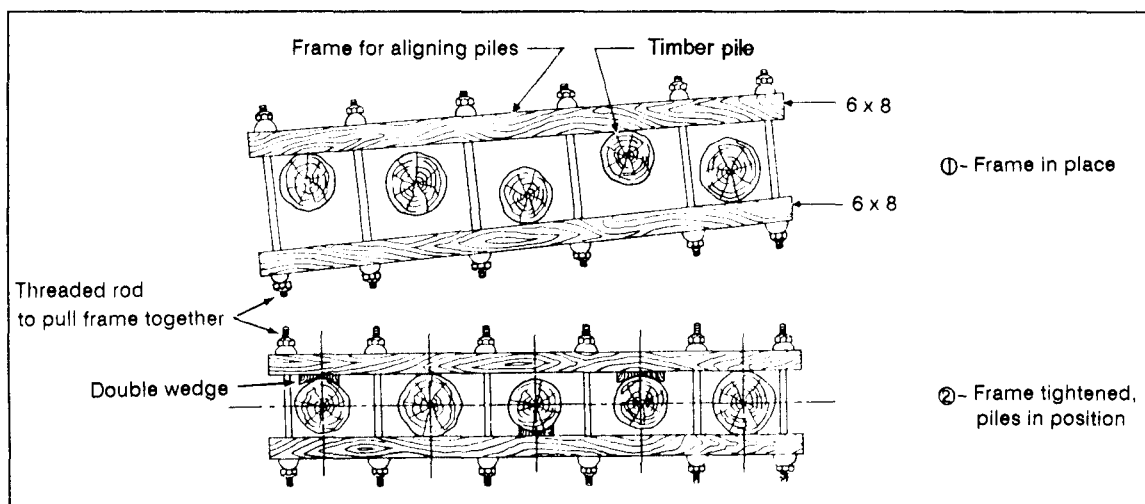

Figure 8-17. Straightening a Pile Using an Aligning Frame

b. Cutting piles. After piles are driven to the desired penetration, they should be 2 to 3 feet higher than the desired finished elevation. Pile capping should bear evenly on every pile in the bent. Cutting must be accurate. The best way to ensure even cutting is to nail sawing guides across all piles in the bent (Figure 8-18).

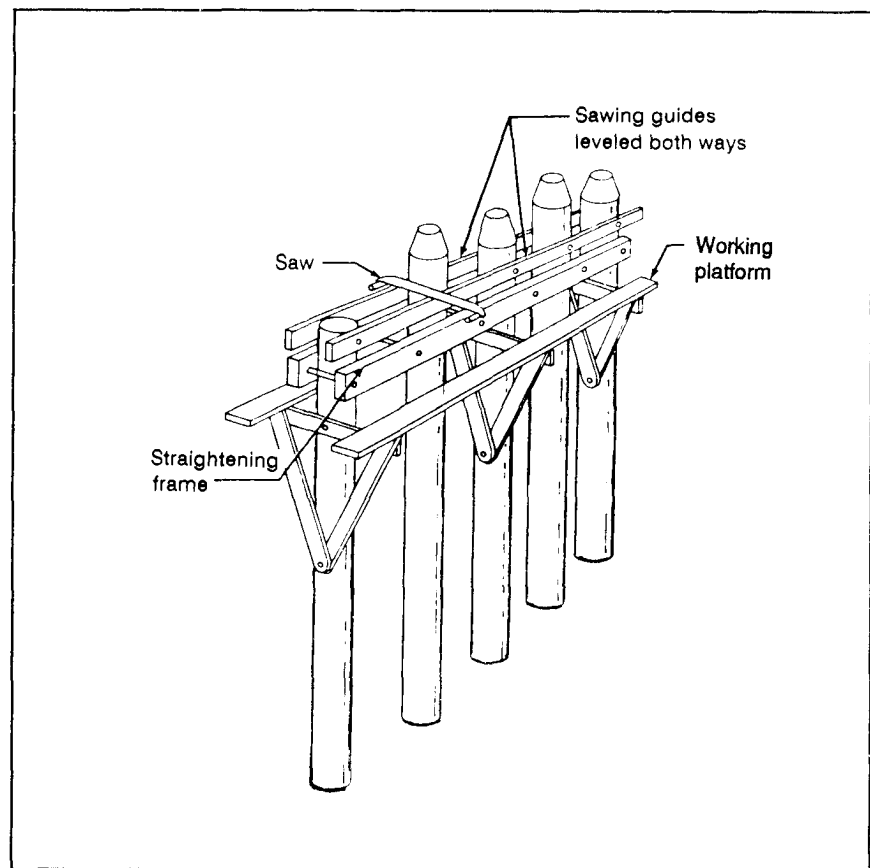

Figure 8-18. Sawing Guides Nailed Across Piles

c. Capping timber piles. The following are ways of fastening pile capping:

(1) Put the cap in place after cutting the piles. Bore a hole for a drift pin through the cap into the top of each pile. Then install the drift pins.

(2) Splice a scab across the joints between pile cap timbers. Bolt the scab to each side of the pile cap.

(3) Remove the working platform and the aligning cables or spacing frame. The drift pins will hold the piles in their proper relative positions.

(4) Leave any excess until after capping is placed.

d. Bracing piles. Bents are braced as follows:

(1) Diagonal timbers are bolted to each pile. Bracing runs in one direction on one side of the bent and the opposite direction on the other side.

(2) Piles in a bent may differ considerably in diameter where braced. Large ones may be flattened down with an adz (dapped). Smaller ones may be blocked out with filler pieces. Flexible braces can pull them tight against one another (Figure 8-19, page 8-20).

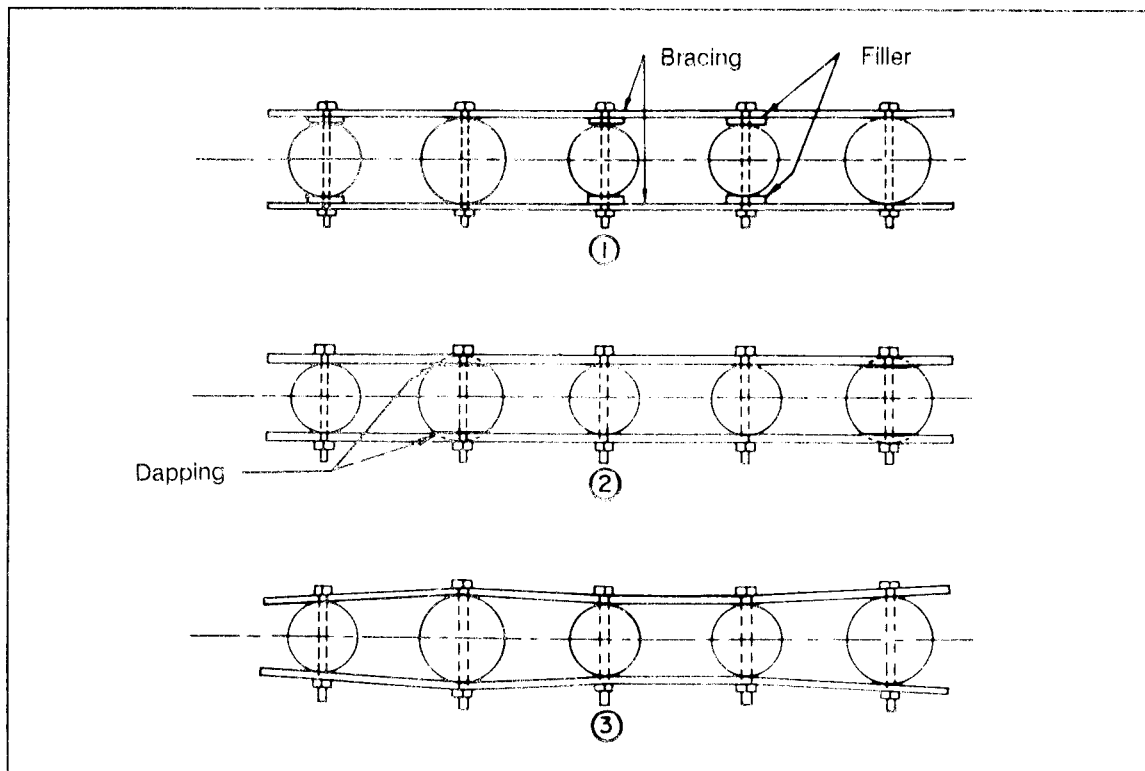

Figure 8-19. Flexible Braces

e. Straightening, cutting, capping, and bracing steel piles (Figure 8-20). Finishing a bent of steel piles follows the same general method as timber piles except-

(1) When bringing the webs of the steel bearing piles parallel to the centerline of the bent, the straightening process may induce twisting.

(2) If the excess length of the pile is cut off, leveling the pile tops justifies any rotting. The piece is welded to the bottom end of another pile.

(3) If the pieces salvaged are so long that the welded joints are below or near the ground, full-perimeter butt welds will give adequate strength. Joints may be above ground level without soil support to resist bending stresses at the weld. When this is true, use web and flange plates as well as butt welding.

LAYOUT FOR POSITIONING PILES

a. Templates. There are several methods to position piles for driving in water. When a floating pile driver is used, a frame for positioning piles may be fastened to the hull. Sometimes engineers use a floating template (Figure 8-21, page 8-22) to position the piles in each bent. Battens are spaced so that the centerline between them is along the line desired for each pile. As the pile is driven, the larger diameter butt end will not bind on the template and carry it under water. A chain or collar permits the template to rise and fall with the tide. The ends of the battens are hinged, and brought up vertically. The tern late may be withdrawn from between the bents and floated into position for the next bent. Several templates may be used for a bent; or, if spacing is uniform, a single template may be used and moved for use with the next group.

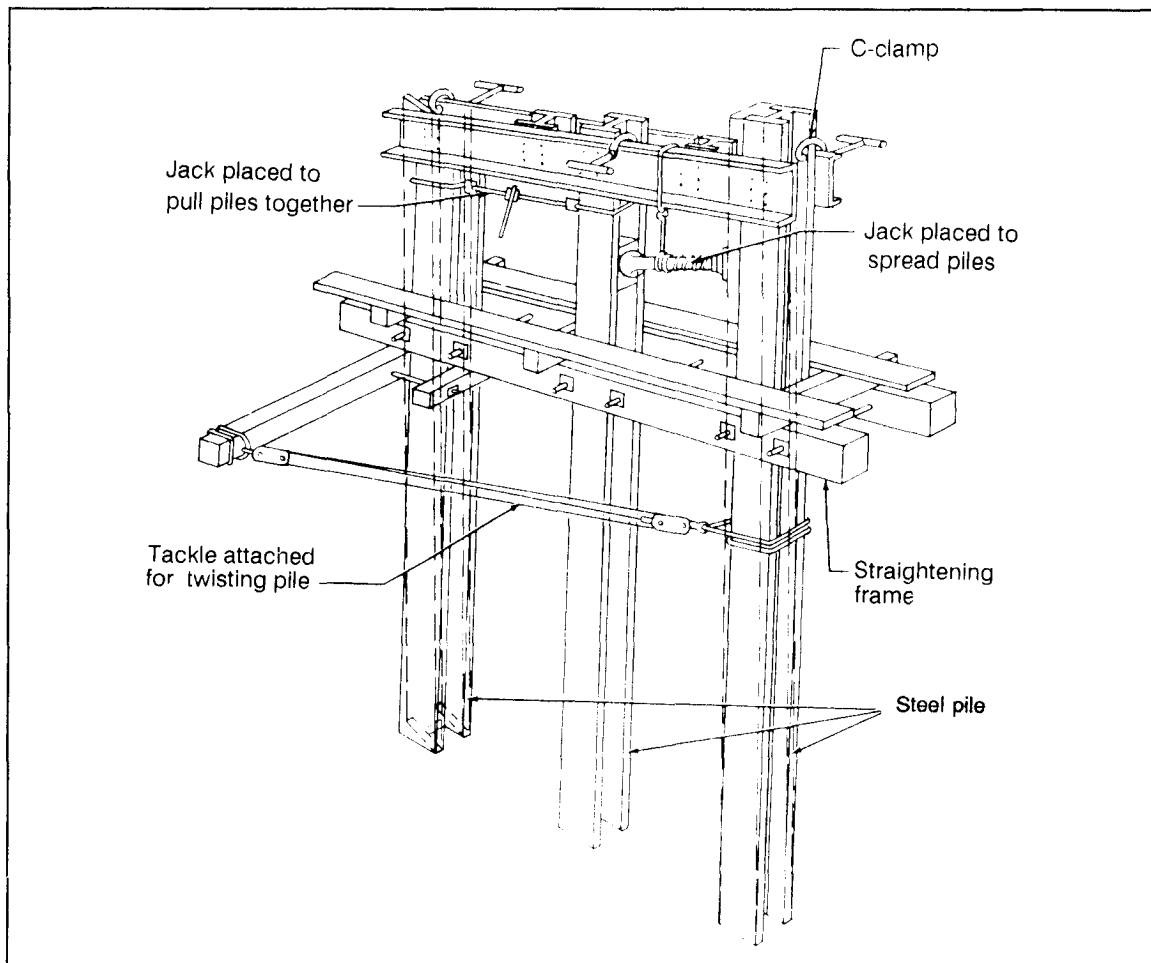

Figure 8-20. Straightening, Cutting, Capping, and Bracing Steel Piles

b. Control of pile positions.

(1) After each bent has been driven, a line is run back from each pile in the outer bent to a corresponding pile several bents shoreward.

(2) The alignment and longitudinal spacing of the out-shore bent is verified.

(3) Any deviation in position of previously driven piles is made up when the template is positioned for the next bent. Piles slightly out of position may be pulled into place later.

PILE-DRIVING PROCEDURES

a. Driving by skid-mounted pile driver. This type of pile driver can be used to drive the piles for an entire structure before the rest of the construction work begins. In general, floating equipment can drive more piles per work-hour because the driver moves relatively easily. Also, as soon as the piles in one bent have been driven, the rig can immediately be repositioned to drive the next bent without waiting until the bent just driven is braced and capped. It is easy to position floating pile drivers, either end-on or side-on, to the pile bent being driven. Thus, batter piles can be driven in any desired direction simply by adjusting the catwalk.

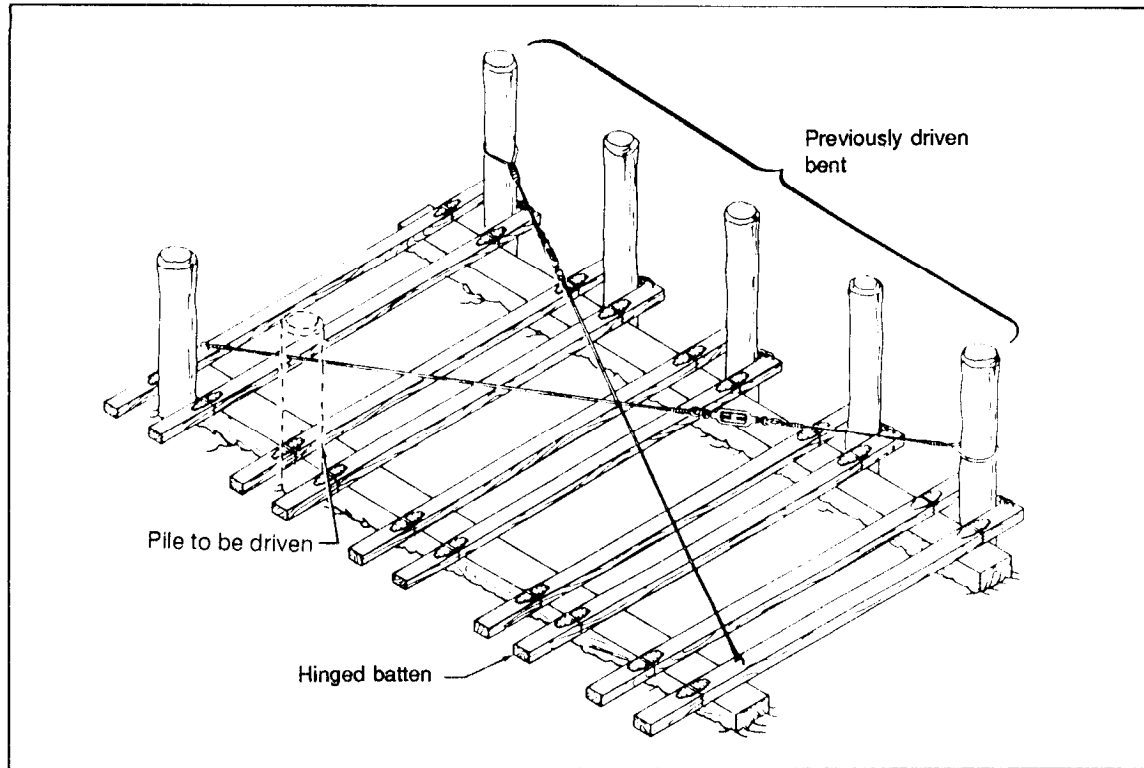

Figure 8-21. Floating Template

b. Driving by mobile equipment. Mobile pile drivers operate from the deck of the wharf structure. Two procedures move the pile driver forward:

(1) Walking-stringer method. As each bent is driven, the piles are aligned, braced, cut, and capped. Movable stringers are laid ahead of the pile driver onto the bent that was just completed. Movable stringers are made by placing spacer blocks between two or three ordinary stringers and bolting them together. Loose decking is laid on the movable stringers so the driving rig can advance into position to drive the next bent. The advance row or rows of piles are braced, cut, and capped. The pile driver then picks up the temporary stringers behind and swings them into place ahead. Permanent wharf stringers and decking are installed behind the pile driver. A variation of the walking-stringer method is possible with the skid-mounted pile driver (Figure 8-22).

(2) Finish-as-you-go method. This is much the same as the Walking-stringer method. In this method, however, the same crew completes each step, one after the other.

c. Comparison of the two methods.

(1) Walking-stringer.

(a) Advantages. The pile driver is idle less with the movable stringer method. Decking operations are completely separate. Separate crews drive, cut, cap, and deck. Such crews become proficient more rapidly than crews which must do all three tasks.

(b) Disadvantages. This method is more hazardous because the machine is supported by loose stringers and decking. It requires more skill and organization because several operations may be in progress at the same time.

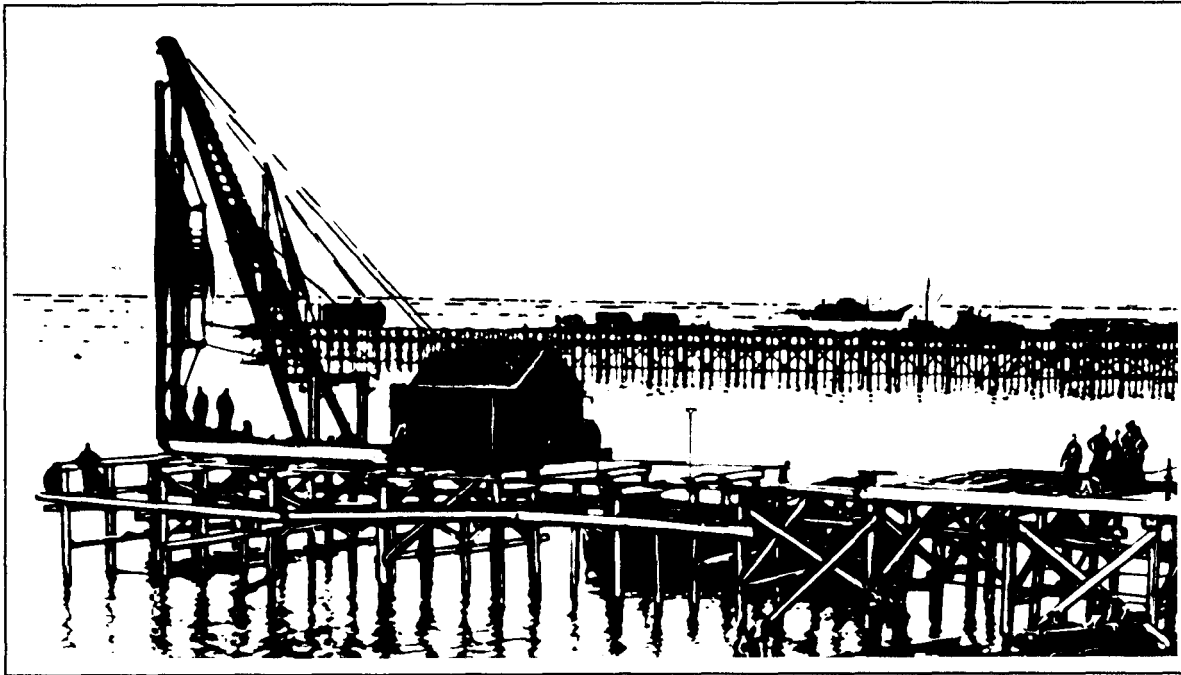

Figure 8-22. Skid-Mounted Pile Driver

(2) Finish-as-you-go.

(a) Advantages. This method is safer and requires less organization since one operation follows another.

(b) Disadvantages. The driver is idle while each panel is completed. All material must be available to continue construction. Personnel must rotate from job to job.

ERECTION OF STRINGERS AND DECK FOR STEEL PILE WHARVES

a. Steel pile bents. Steel piles in bents must be driven with their webs parallel to the wharf centerline. If not, piles are rotated as they are aligned and capped.

b. Nailers. Nailers are bolted to the wide flange (WF) beam pile cap.

c. Stringers. Establish correct stringer spacing by placing the first stringer on the centerline of the wharf. The centerline is on the nailer of each bent. Timber stringers are toenailed to the nailer with 3/8- by 10-inch spikes at each bearing point. An overlap is provided at the bearing points where stringer ends overlap. Spacer blocks are inserted between parallel stringers atop each nailer.

d. Decking. Standard timber decking consists of 4 by 8-inch planks spiked to each stringer using two 5/16- by 7-inch spikes. They are set with 1/4-inch open joints. Openings between planks greater than 1/4 inch may serve in areas subject to heavy rains.

e. Stringpiece. The stringpiece, or curb, is placed on filler blocks spaced at intervals along the edge of the deck. Stringpiece bolts are countersunk and the hole sealed with bituminous material in one of two ways:

(1) When the stringpiece is parallel to the wharf stringers, it is bolted through the blocking, the decking, the stringer end piece, and the nailer.

(2) When the stringpiece is perpendicular to the wharf stringers, it is bolted through the blocking, decking, alternate stringers, and pile cap (Figure 8-23).

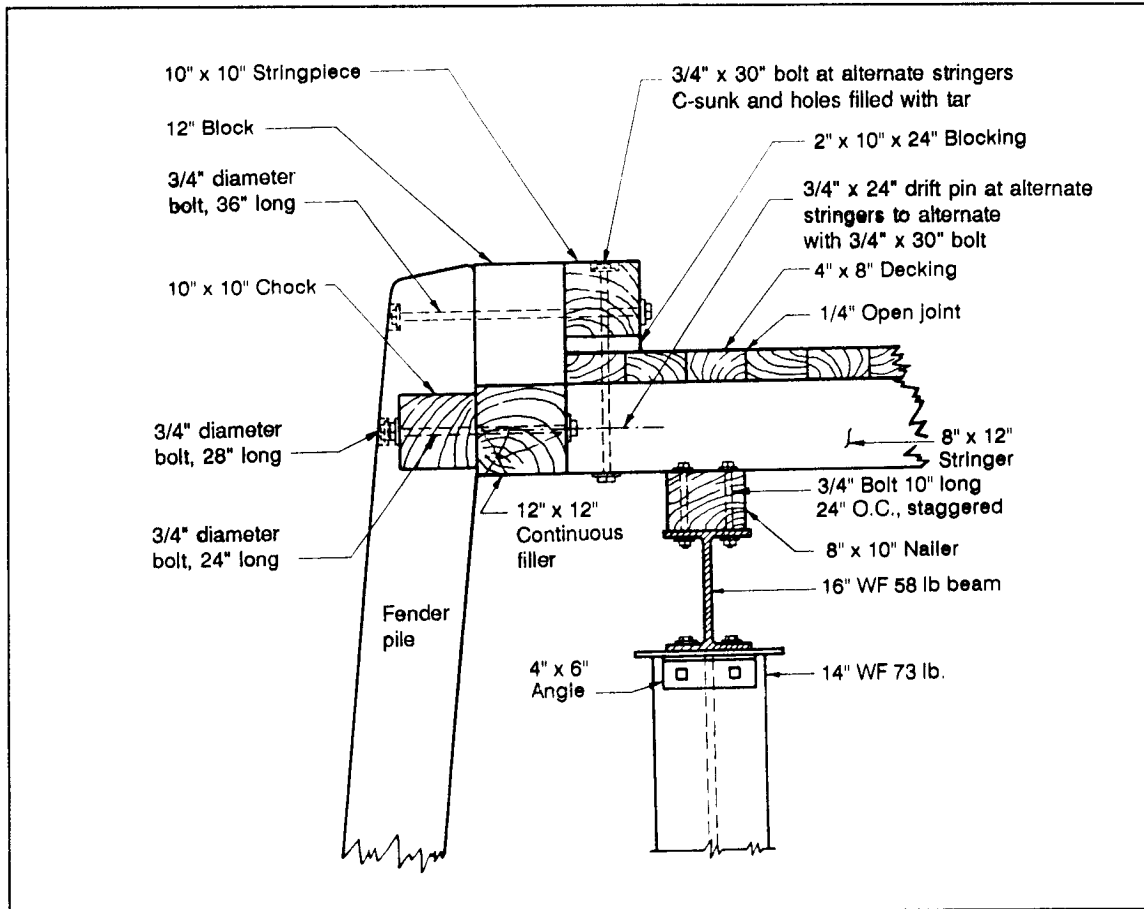

Figure 8-23. Installing a Stringpiece

CONCRETE SURFACE FOR TIMBER DECKS

- a. Pile bents. Steel or timber piles are aligned, braced, and capped as discussed earlier.
- b. Stringers. Timber or steel stringers and nailers are installed as discussed earlier.
- c. Timber deck. A tight timber deck, consisting of 4- or 6- by 8-inch planking, is spiked to each stringer. All knotholes or openings in the decking wide enough to leak mortar are covered. Green lumber is suitable for the flooring under concrete.
- d. Installing mooring hardware. Stringers are reinforced; or, a timber grillwork is installed at bollards or where other heavy items of mooring hardware are to be installed. Mooring hardware may be installed on a timber platform (Figure 8-24, page 8-25) bolted diagonally through decking and stringers. A timber screed (6 by 12 inches) is spiked to the deck between the concrete pour area and the base of the hardware mount. Pile caps are placed on the six piles adjacent to the mooring hardware. Longitudinal cross-bracing is used between the outside bearing piles of at least two pile bents at the bollards.

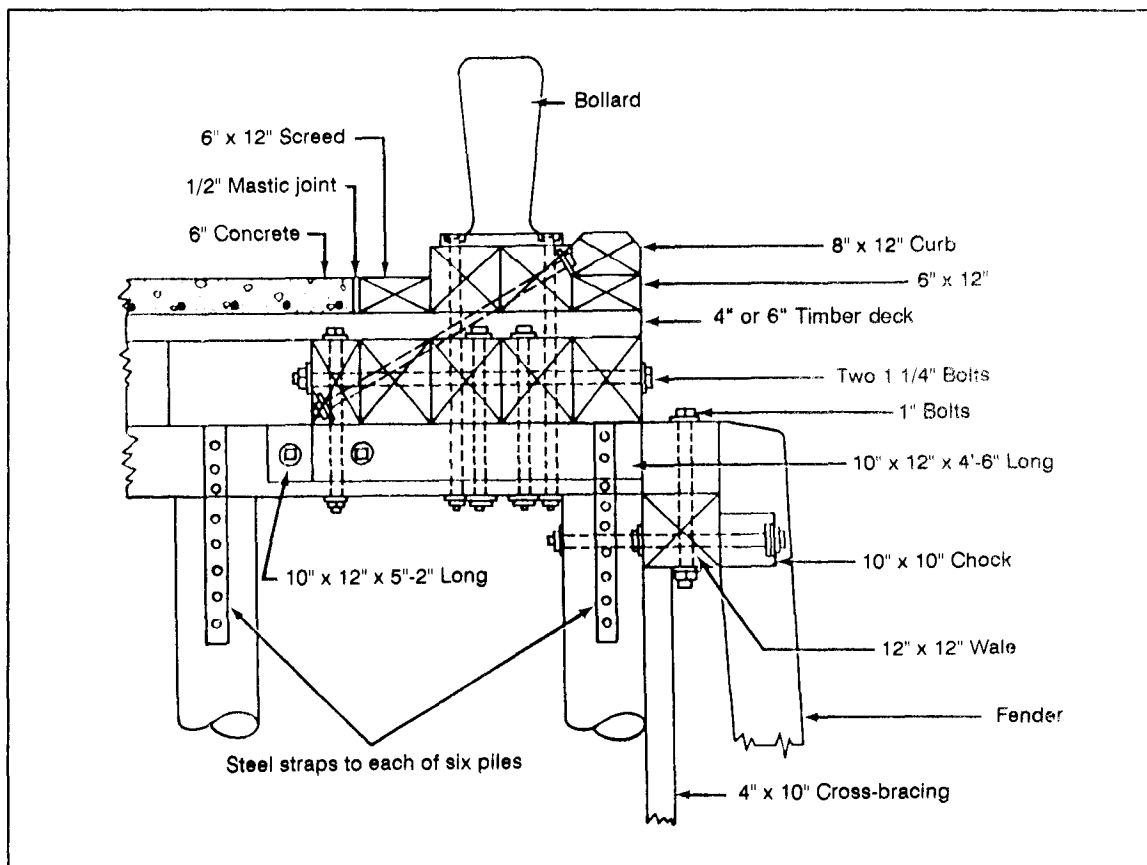

Figure 8-24. Timber Platform with Mooring Hardware Installed

e. Edging. To retain the concrete, 6- by 12-inch timbers are laid around the edges of the wharf flooring except at scupper openings. They are bolted through the decking, stringer endpiece, or alternate stringers. A 6-inch concrete deck is laid after reinforcement is placed.

f. Reinforcement. To lessen cracking due to temperature changes, the deck is reinforced horizontally in two directions with straight or deformed bars or wire fabric with 12-inch maximum mesh. The bars should not be spaced more than 18 inches apart. The amount of reinforcing steel should not be less than 0.0025 times the cross-sectional area.

g. Joints. Traverse and longitudinal joints are normally provided for concrete expansion and contraction. They are placed no more than 30 feet apart. Vertical grooves may be used to divide the concrete into sections. Use 1- by 6-inch oiled timbers to fill the grooves. As soon as the concrete is set, the timber and all soft concrete are removed and the joint is filled with mastic filler.

h. Scupper openings. To drain water from the deck, a scupper opening is provided. Place 5- by 12-inch timbers 3 feet in length between the 6- by 12-inch edging timbers. Fasten them through the decking and stringers using two bolts. The concrete slab is tapered to 5 inches at the scupper opening.

i. StringPiece. The stringpiece is fastened to the edging with countersunk bolts. Holes are sealed with asphalt filler.

j. Curing. Concrete must be protected from excessive loss of water until it has achieved about 90 percent of its intended strength. Cover it to prevent excessive evaporation before it dries at the surface or keep it wet. Standard curing practices, applicable to roads and runways, apply to concrete surfaces for timber decks.

CONCRETE PILE WHARVES WITH REINFORCED CONCRETE DECKS

a. Cutting piles. Use pneumatic cutters and drills to cut reinforced concrete piles to the proper elevation. Use acetylene torches to cut the steel reinforcement bars. In Figure 8-25, part of the piles have been cut to elevation, exposing the steel bars which will project into the girder. The falsework for girder, beam, and slab is under construction.

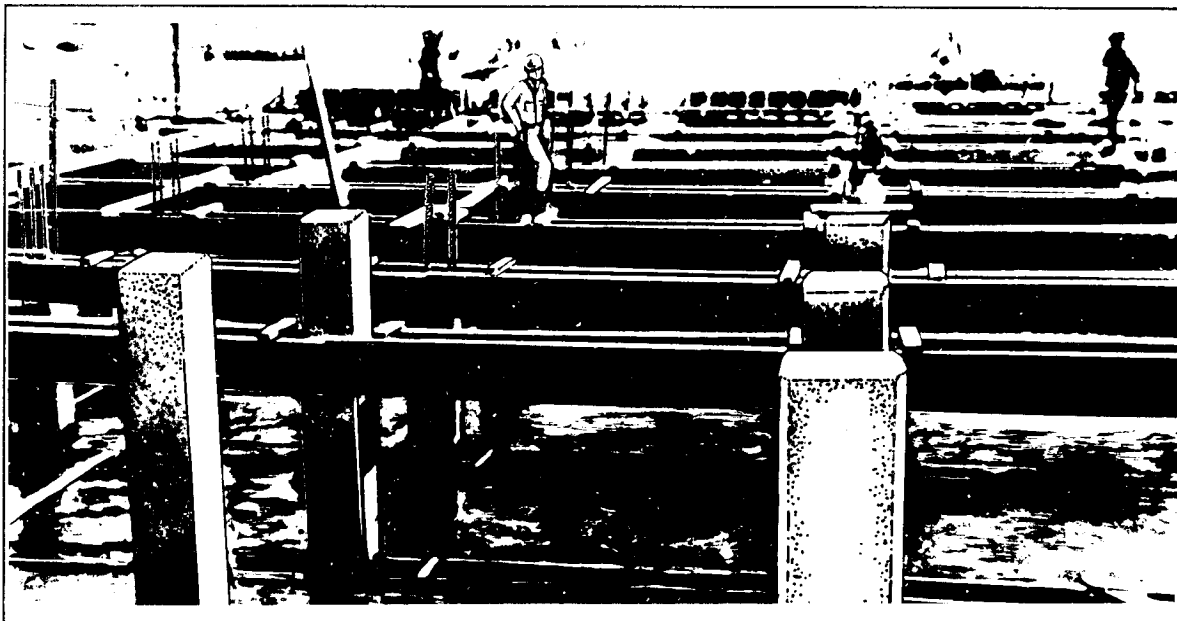

Figure 8-25. Piles Cut to Elevation Exposing Steel Reinforcing Bars

b. Reinforcing steel. Beams and girders are reinforced with longitudinal deformed bars and vertical stirrups. Figure 8-26 shows these in position in the completed deck falsework. To attain continuous slab construction, turn one-half of the slab-reinforcing bars up over the beams. Cut half the bars equal, in length, to the span of the slab plus one-fourth of the span of each adjoining slab. Turn the ends up over the supporting beams from each adjoining slab. The same area of steel is secured over the beam or girder as found in the center of the span. For reinforced concrete work, design drawings should show bending details for the bars. Typical beams and girders should be detailed to show concrete dimensions, required bar lengths, number of turned-up bars, and the number, size, and spacing of stirrups. The construction engineer uses these drawings as a guide for reinforcement bending details. When cutting straight bars to the correct length, he can field-bend them with a bending lever less than 3/4-inch in diameter. Temperature bars are always straight. Deformed bars are generally used for all reinforcement except stirrups, which may be plain bars. Bending stirrups in the field requires detailed drawings. Stirrups are wired to main bars. Reinforcing steel must be accurately located in the forms and held firmly in place before and during pouring. If spacers are not available, block the steel up on cement briquettes and wire it firmly in place.

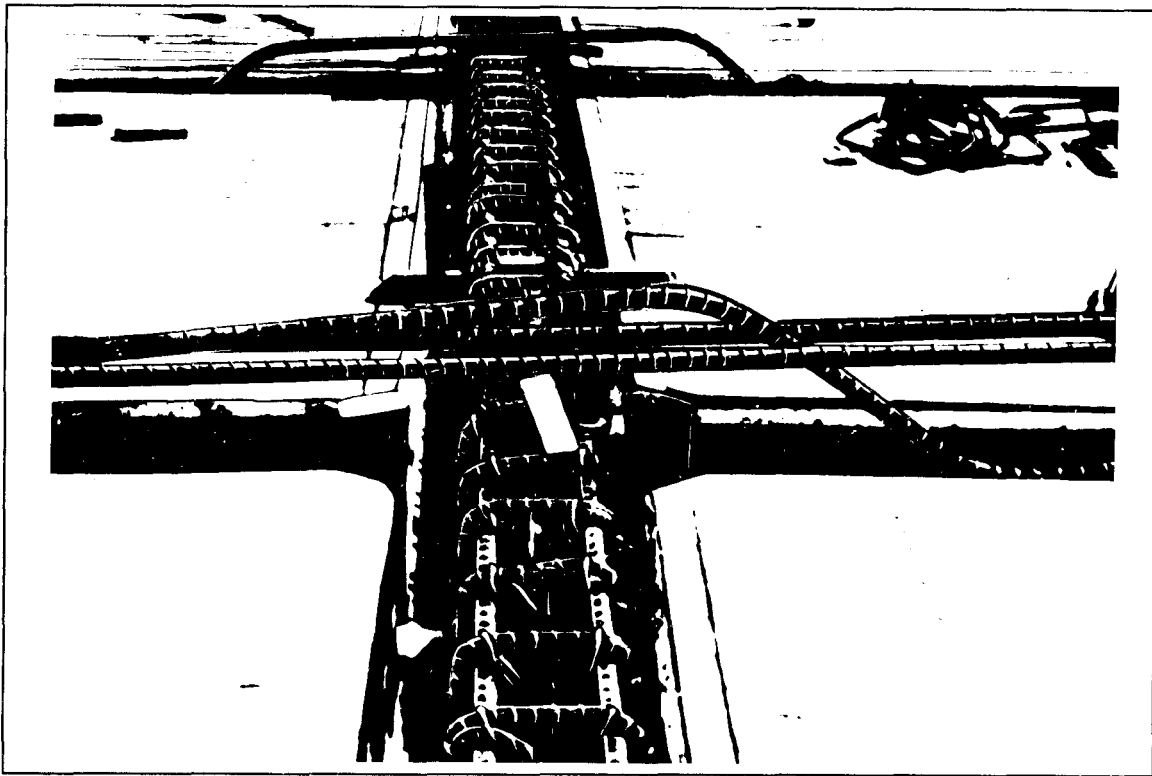

Figure 8-26. Reinforcing Steel

c. Forms. Engineers should oil forms before placing the concrete so they can be removed and reused. Concrete must be carefully cured. Forms must be kept in place until the concrete has attained enough strength to support itself, and all loads placed on it, before they can be removed or reused. In warm weather, beam strength may develop in 2 or 3 weeks. Low temperatures require more time. Forms should be removed carefully and the concrete examined.

d. Fenders. Concrete wharves are protected with timber fender systems and pile clusters along their faces. Figure 8-27 shows pile clusters several feet above deck elevation that are used to supplement or replace mooring hardware.

e. Mooring hardware. Mooring hardware is fastened to the deck with bolts passing through pipe sleeves set in the concrete. The base of the fitting sits in a recess formed in the deck. After bolting, the fitting is also set in the recess and grouted. This transmits the shear from the line pull directly to the concrete deck.

INSTALLATION OF STRINGERS AND DECK FOR TIMBER PILE WHARVES

a. Timber pile bents. Timber pile bents are aligned, braced, and capped as previously described.

b. Stringers. The pile cap of each bent is on the centerline of the wharf with the stringers set off from this point. The stringers are toenailed to the pile caps, using two 3/8-by-10-inch spikes at each bearing point. The ends of the stringers are over appeal to provide complete bearing on the pile caps. Spacer blocks between stringers are toenailed with two 60d spikes.

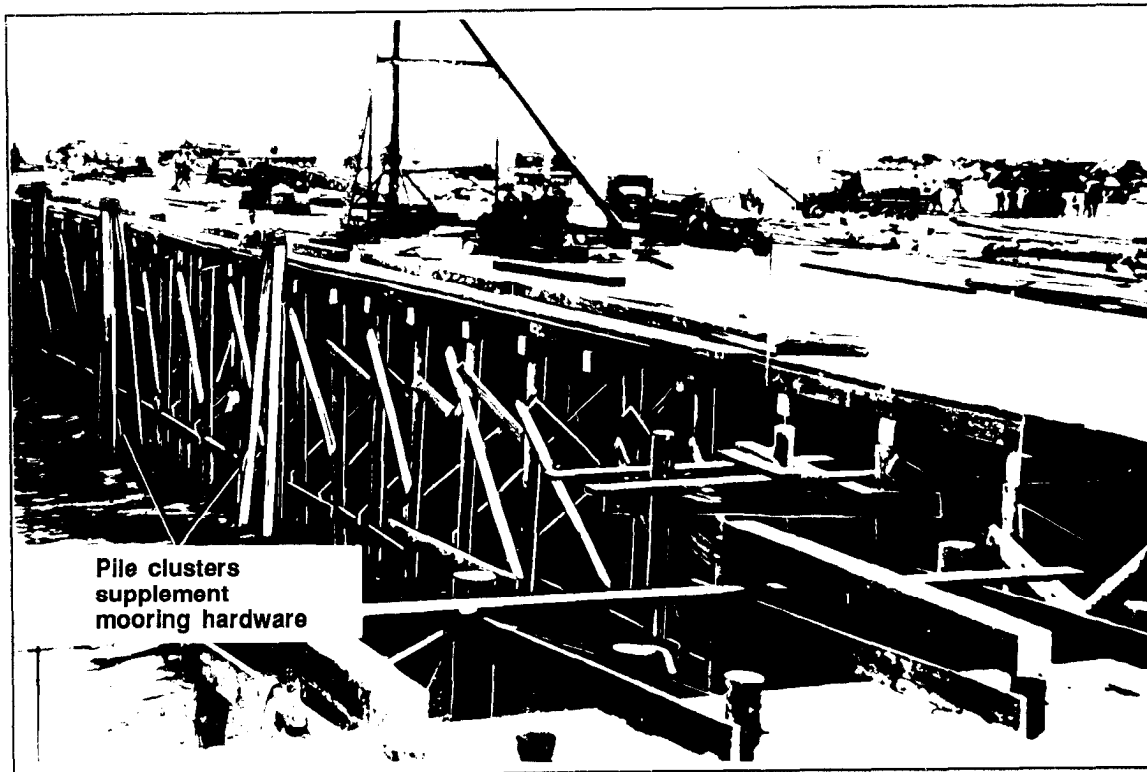

Figure 8-27. Pile Clusters Used to Replace/Supplement Mooring Hardware

c. Decking. Standard decking consists of 4- by 8-inch Planks spiked to each stringer using two 5/16- by 7-inch spikes, and set with 1/4-inch open joints. Openings between planks greater than 1/4-inch may be used in areas with heavy rains.

d. Stringpieces. The stringpiece or curb (Figure 8-28) is placed on 2- by 10-inch blocking, 24 inches length, spaced on 48-inch centers along the edge of the deck. Stringpiece bolts are countersunk and the holes sealed with bituminous material. The stringpiece is bolted as described earlier for steel pile wharves.

ERECTION OF FENDER SYSTEMS

a. Fender systems consist of fender piles, corner fender pile clusters, chocks, and wales.

(1) Fender piles. Fender piles are driven at a slight batter. The batter is usually 1 to 12 inches along the outside edge of all rows of bearing piles except the inshore sections where ships do not berth.

(2) Chocks and wales.

(a) Chocks are placed between fender piles at the level of the stringpiece or pile cap. Dapping is necessary to firmly seat the chock against the fender pile.

* Timber pile wharves. Each chock is fastened with two bolts through the stringer end piece or pile cap.

* Steel pile wharves. Each chock is bolted to 12- by 12-inch blocks drift pinned to the ends of the stringers or bolted to the ends of the WF pile cap.

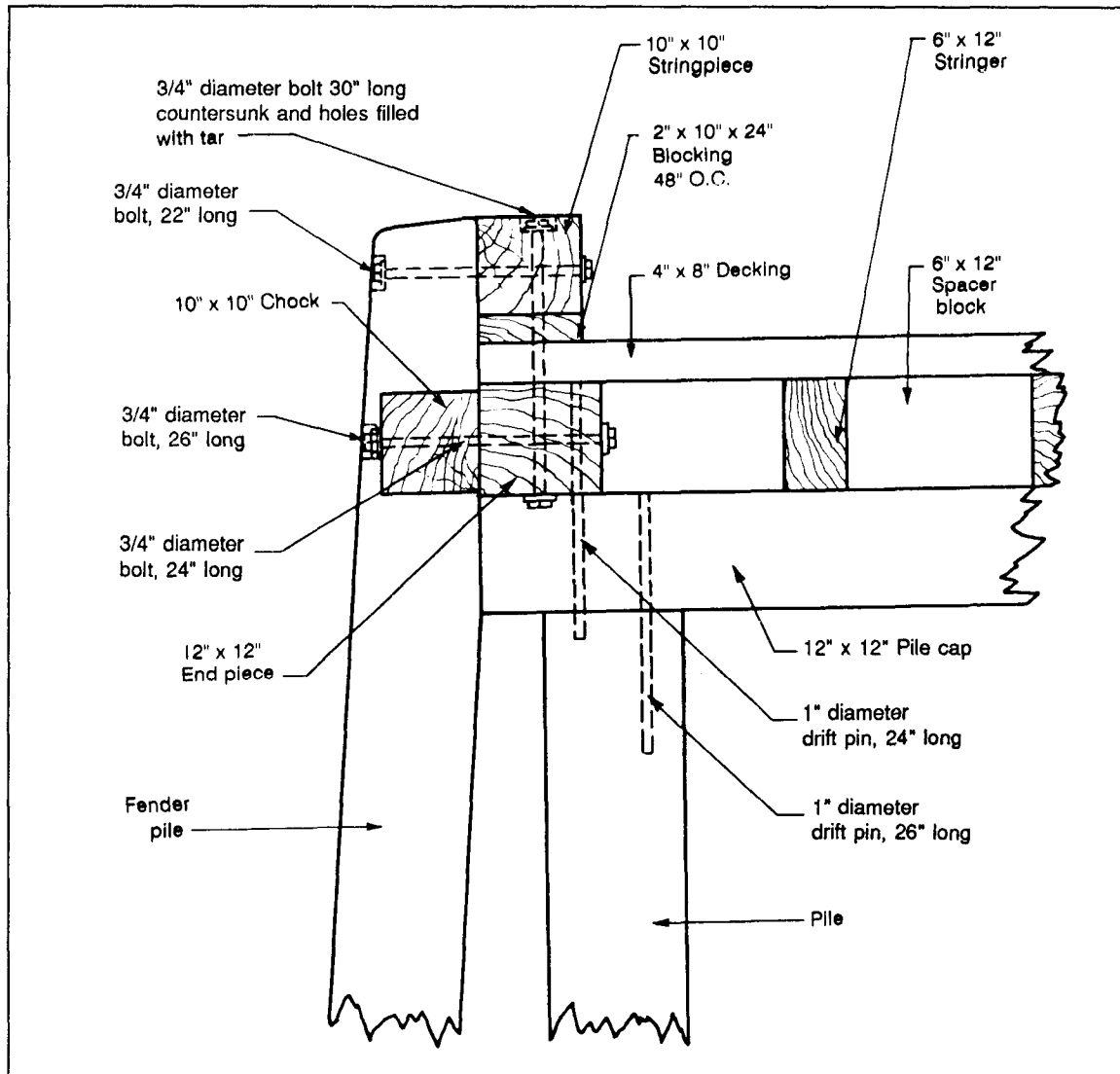

Figure 8-28. Stringpiece

(b) Chocks at mean low water level allow additional rigidity to wharf structures. A continuous timber wale, 12- by 12-inches long, is fastened to the back of each fender pile using countersunk bolts. Fender piles are clapped and the chocks and wale bolted together to firmly seat the chocks.

b. Deck reinforcing at corner fenders.

(1) Wood pile wharves. A ten-pile corner fender may reinforce the outer corners of the wharf deck. Prior to setting stringers, wood piles battered inward are driven to support a cap. The cap is set diagonally across each corner and bolted to the bottom face of the other cap. Another piece of cap timber is set to act as a strut between the fender cluster and the diagonal cap. The space between the cluster and the diagonal cap is then floored with two layers of 6-inch thick plank, laid diagonally (and transversal to each other) to fill the space between the cap timbers. Stringers are set close and spike together over the outer half of each corner panel to complete the reinforcement.

(2) Steel pile wharves. In steel pile marginal wharves and in piers with corner fenders, timber reinforces the deck in each corner panel. Wood piles, battered inward, carry a diagonal timber cap bolted to the bottom flanges of the steel pile caps. The diagonal cap is strutted against the fender cluster, and diagonal layers of plank are applied. The stringers are set close and spiked together as described for wood pile wharves.

INSTALLATION AND BRACING OF DOCK HARDWARE

a. Installation of heavy items.

(1) Stringer reinforcement. Install stringer reinforcement and timber grillwork anchorage at the bollards, bitts, heavy cleats, and chocks. Stringers lie close together for reinforcement. They are spiked to each other at each bearing point.

(2) Timber grillwork. Timber grillwork (Figure 8-29) is bolted to the pile caps. Cross timbers and filler timbers are bolted together through all sections of the grillwork.

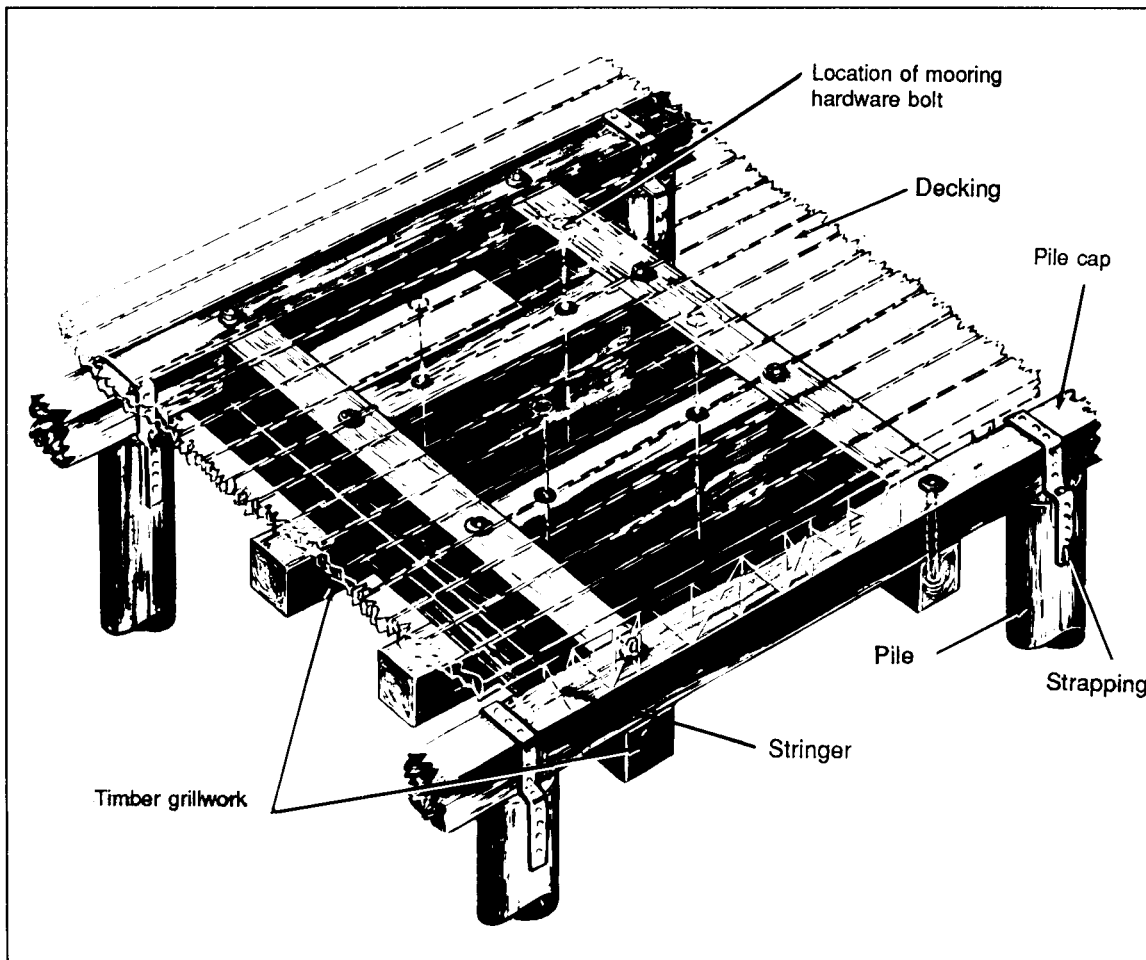

Figure 8-29. Timber Grillwork

(3) Steel strap. Each pile affected by upward pull on the grillwork is fastened to the pile cap using 3/8-inch steel straps.

(4) Cross bracing. Diagonal bracing, including three bents, is carried from just below the pile caps to the low-water level at each bollard. The cross bracing is bolted to each pile.

(5) Bolts. Bolts for hardware must be long enough to pass through all sections of anchorage.

b. Installation of light items. Light items of mooring hardware, with bolt centers less than 8 inches, such as cleats, chocks, and pad eyes, are bolted through the stringpiece, blocking, decking, and stringer end piece.

PILE CLUSTERS

Pile clusters usually consist of three piles. They may be driven at 50-foot intervals along the face of the wharf to supplement or replace mooring hardware. The clusters are wrapped near the top.

CHAPTER 9

WHARF HARDWARE, FENDERS, AND DOLPHINS

TYPES AND USES OF WHARF HARDWARE

Ships tie up to wharves with lines fastened to mooring fittings such as bollards, corner mooring posts, and cleats.

a. Bollards. Whether single- or double-bitt, bollards are steel or cast-iron posts (Figure 9-1) to which large ships tie up. To prevent ships' lines from riding up off the post, bollards may have waists smaller than their tops, or they may have caps or projecting, rounded horns. Double bitt bollards are also known as double steamship bitts or simply as double bitts. Bollard bodies may be hollow for falling with concrete after installation. Bollards were once designed to take line pull loads of about 35 tons. Modern container ports usually have bollards with 100-ton line pull capacities.

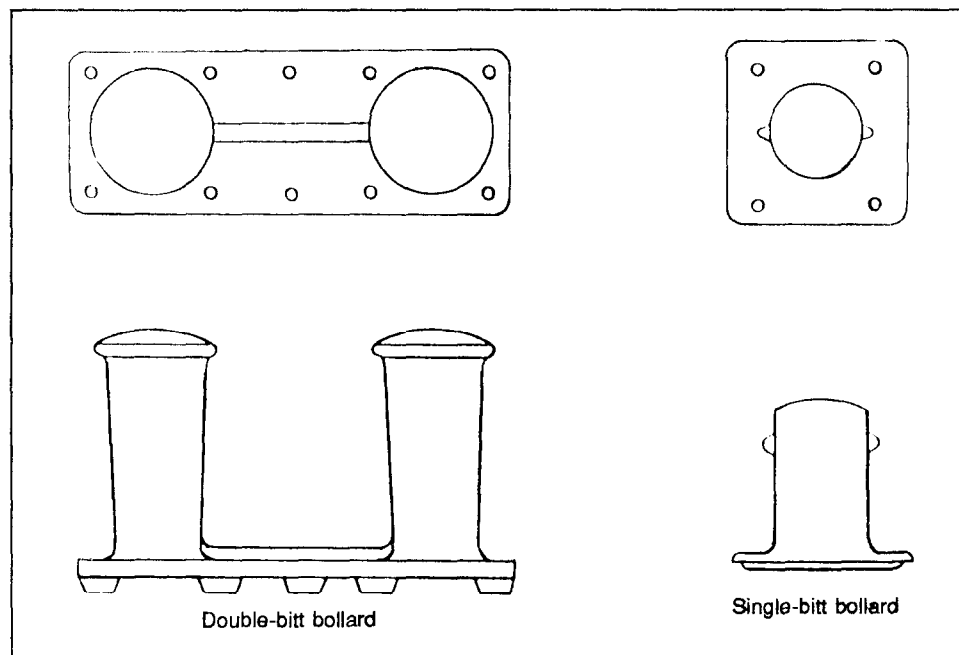

Figure 9-1. Single- and Double-Bitt Bollards

b. Corner mooring posts (Figure 9-2). Corner mooring posts are larger than bollards. They are fastened at the outshore corners of a pier, wharf, or quay. These posts are used to bring the ship into the pier or around a turning dolphin, as well as to secure lines. Once designed to take line pull loads of 50 tons, they are now designed for loads of up to 100 tons.

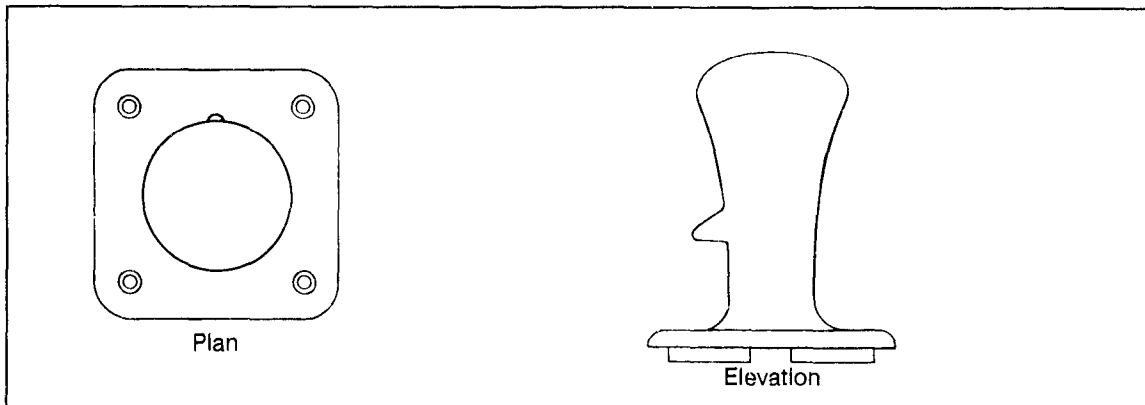

Figure 9-2. Plan and Elevation Views of a Corner Mooring Post

c. Cleats (Figure 9-3). Cleats are cast iron with arms extending from a low body. The base may be open or closed. They secure small ships, tugs, and work boats.

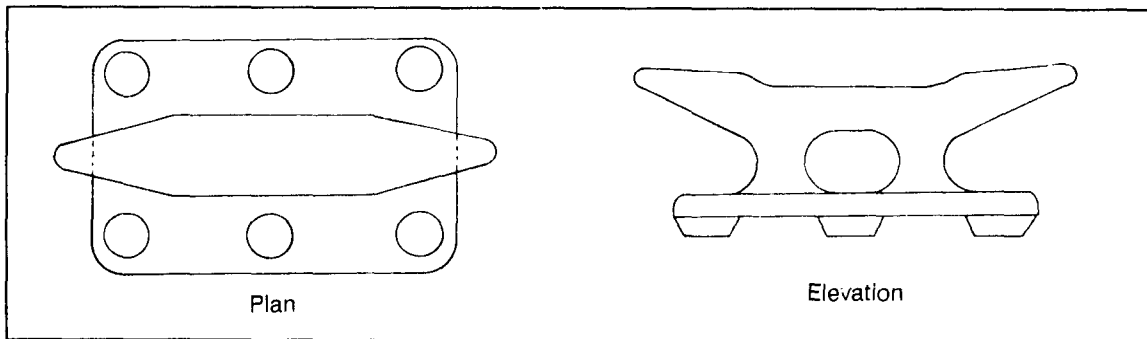

Figure 9-3. Plan and Elevation Views of an Open Wide-Base Cleat

d. Chocks (Figure 9-4). Chocks are usually timber braces. However, open or closed chocks are made of cast iron. They direct lines and snub lines when working a ship into or out of a berth. A closed chock may be used for a change in the vertical, as well as the horizontal, direction of the line.

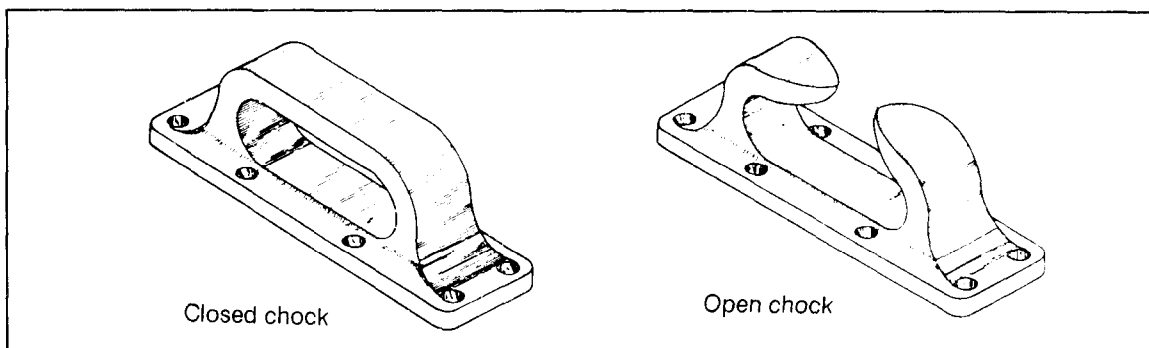

Figure 9-4. Chocks

e. Pad eyes (Figure 9-5). Pad eyes are metal rings mounted vertically on a plate to receive a ship's line. Spliced with thimble and shackle, they are used only for small craft.

f. Power capstan (Figure 9-6). Power capstans are vertical drums operating on spindles. They are used to pull long, large wire-rope lines, especially when the lines are attached to dolphins. Capstans operate electrically or by air.

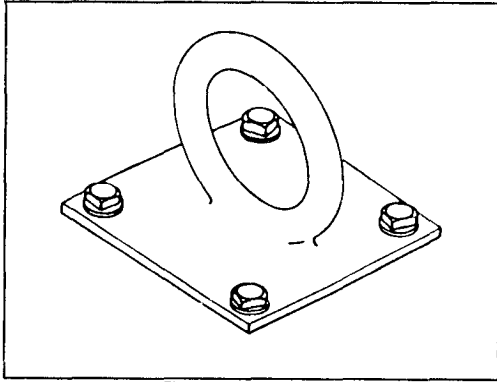

Figure 9-5. Pad Eye

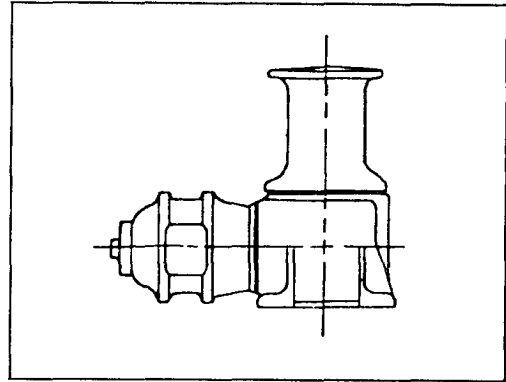

Figure 9-6. Power Capstan

Releasing hooks (Figure 9-7). Releasing hooks on the ends of mooring lines are attached to buoys, or to dolphins reachable only by service boats. Releasing hooks allow the lines to be detached from the anchors by tripping the hooks with small rope lines running from the releasing hook to the ship.

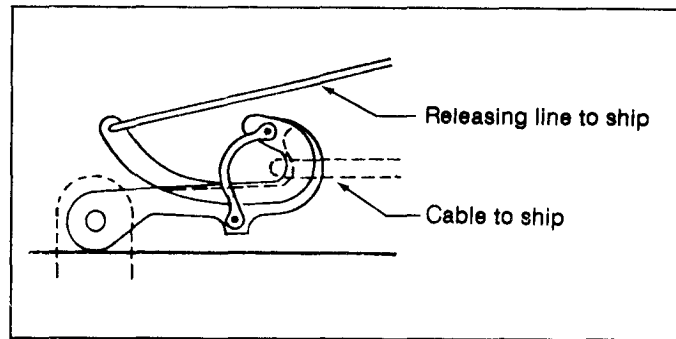

Figure 9-7. Releasing Hooks

INSTALLATION OF WHARF HARDWARE

a. Currently approved AFCS wharf or pier designs apply mostly to timber wharf or pier construction.

b. Concrete decks. Wharf or pier hardware for commercial concrete decks is positioned from 30 to 80 feet apart, depending on the type of hardware and ships to be accommodated. Fittings are fastened to the deck curb with galvanized bolts that pass through pipe sleeves set in the concrete. This technique allows removal of the bolts and accessories if necessary.

c. Steel decks. The decks of DeLong and Marathon-LeTourneau (M-L) self-elevating, spud-type barge piers are provided with mooring hardware, usually single- or double-bitt bollards. Bollards for spud-type barge pier decks are now designed for a 100-ton line pull and weigh 4.3 tons per assembly. Twelve such bollards, six per side, are usually specified for each of the large 300-foot units. The small 150-foot units carry from four to six bollards. Designs for these mooring units are available only upon request from the two manufacturing corporations: DeLong and Marathon-LeTourneau.

FENDER PILES AND CHOCKS

a. Use of timber. Timber is suitable for use as permanent or semipermanent wharf fenders in the TO. Fenders serve the following purposes:

(1) They cushion a wharf from the impact of ships and protect the outer row of bearing piles.

(2) They protect the hulls of ships from abrasion.

(3) The 3- or 4-foot extension of a fender pile above the deck of a wharf supplements wharf mooring hardware. They are not, however, used for warping a ship into or out of the berth.

b. Ease of replacement. Since fender piles are not part of the structural support of the wharf, they are easier to replace than bearing piles.

c. Common methods of protecting fender piles.

(1) A heavy replaceable timber wearing-ribbon is installed along a line of fender piles at the elevation which receives the heaviest abrasion.

(2) Floating logs or camels.

(3) Rope wrappings, particularly on corner fenders.

(4) Wales behind piling to absorb part of berthing forces during mooring (Figure 9-8).

(5) Wales in front of and behind the piling. Rear wales are connected to the wharf deck with short sections of cylindrical rubber fender. The placement of short sections makes a timber pile fender system more flexible. It can accommodate the larger berthing forces of container ships and is the most widely used type.

d. Fender piles for quays. Completely rigid structures include solid-fill quays. Sometimes these quays have their fender piles backed up with heavy springs to combine yielding and resistance.

e. Installation. Fender piles are driven at a slight batter, usually about 1:24. They stand beside each outside structural pile except on the extreme inshore wharf sections. In timber fendering with bolted sections of wales and chocks, the bolt holes should be drilled the same diameter as the bolt. All holes on the face of the fender should be countersunk. All fender hardware should be galvanized. Every third fender pile may extend 3 to 4 feet above the curb. The others are cut off flush with the top of the curb.

f. Chocks and wales.

(1) Chocks are timber braces placed between fender piles to hold the piles in position. The ends of the chocks should be firm against the piles.

(2) Wales may be used near the mean low water line where tidal currents are swift or tidal variations are great. Timber chocks are usually placed between fender piles and are bolted to the wales. They add rigidity to the line of fender piles. They serve as a continuous line backing at the top of some fender systems.

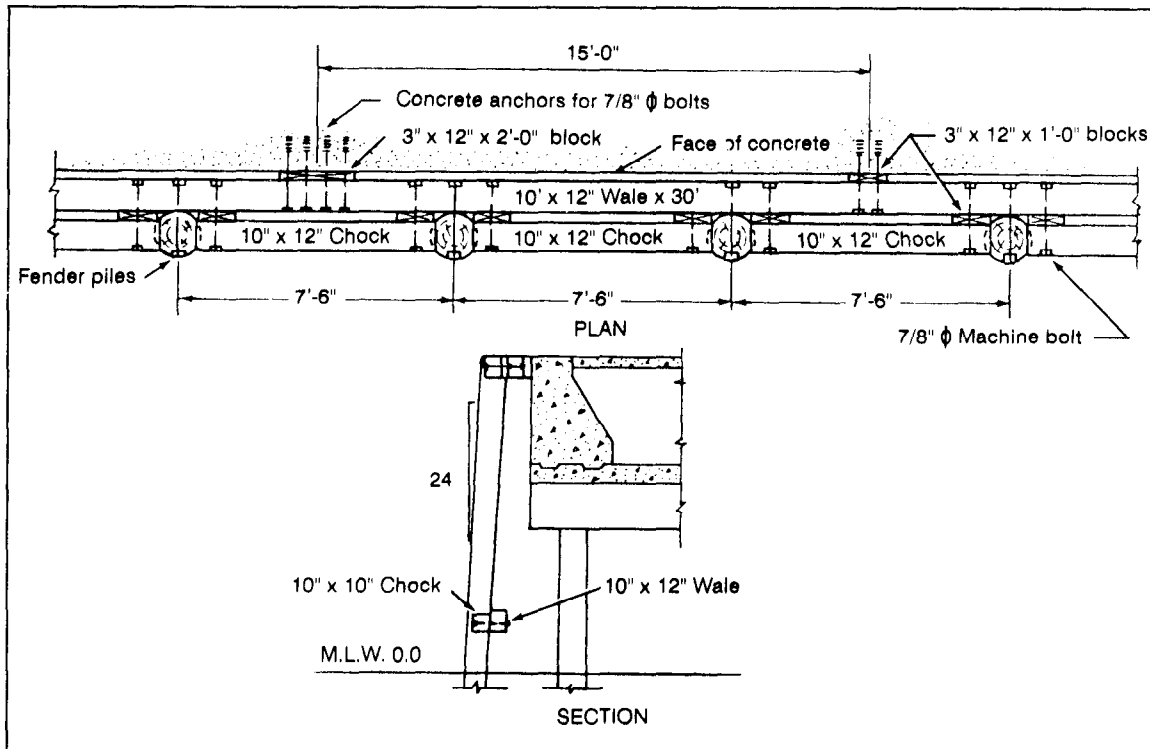

Figure 9-8. Wales

PILE CLUSTERS AND CORNER FENDERS

Pile clusters stand at the faces or corners of wharves or act as isolated dolphins. They must combine beam strength and rigidity with stability against the horizontal stresses of the piles. Therefore, individual piles making up the clusters must be joined so the cluster acts as a unit.

a. Corner fenders. Corner fenders are piles driven in clusters at the exposed corners. Bolted and lashed together, corner fenders allow ships to pivot in the corner while warping in and out of a berth. The corners of a timber wharf structure are strongly reinforced with layers of diagonal planking, laid one across the other. Diagonal batter piles reinforce this backing. The standard corner-fender cluster is made up of 10 piles battered to allow adequate spacing at the points. Timber connectors may be used with the bolts to tie the piles more firmly into a single rigid member. To avoid abraiding the hulls of ships and outside pile surfaces, heavy rope mats may be lashed to the clusters at the level of contact. Corner piles extend three to four feet above deck level to supplement mooring hardware.

b. Mooring piles.

* Mooring piles are clusters of three or more piles used to supplement or replace wharf mooring hardware. The top of the cluster is lashed.

* They are placed at intervals along the face of a wharf without bollards or other items of mooring hardware. A maximum of 3 piles of each cluster may extend 3 feet or more above the wharf deck (Figure 9-9).

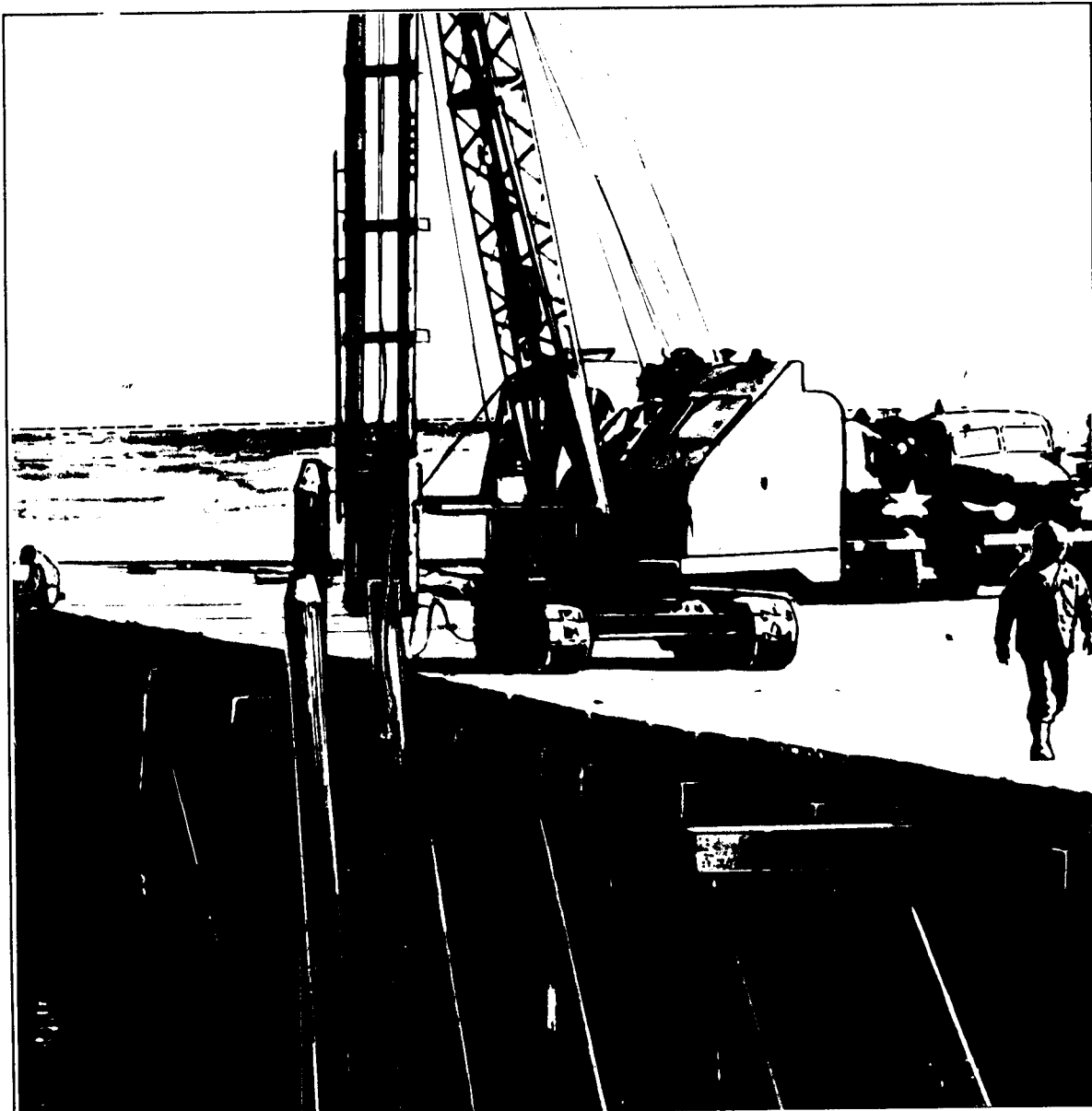

Figure 9-9. Mooring Piles

FLOATING LOG FENDERS (CAMELS)

a. Floating logs absorb part of the impact when a ship is berthed. They protect the surface of fender piles while the ship is tied up. The simplest type of fender is a single line of floating logs. Each log is secured by two or more lengths of 1/2-inch galvanized chain fastened to 3/4-inch eyebolts in the fender log and wharf pile. Some arrangements, such as loose steel collars around the wharf piles, permit the floating logs to rise and fall with the tide.

b. Floating clusters of logs or strongly constructed rafts are called camels. They absorb impact shock and protect fender piles from the sliding friction of a ship moving in the berth. Camels may breast a ship off the face of the wharf into water deeper than that at the face.

PILE MOORING DOLPHINS

a. General. Dolphins are independent marine structures for mooring ships. They consist of a group of timber piles bound at the top with cable or wire. The term dolphin also refers to any other structure that serves the same purpose. Successful designs include sheet pile cells, single large-diameter steel piles like those employed with the DeLong Barge, and clusters of small-diameter steel pipe.

b. Construction of timber pile cluster dolphins.

(1) Basic considerations. Normally driven small end downward, there are times when timber piles should be driven butt down. Factors influencing this decision are: length of pile, depth of water, and type of soil. Short piles driven into shallow water with a hard bottom may be driven with the butt end down. This allows a larger portion of the pile to absorb the bending moment stress. Another consideration is the displacement of soil when 19- and 30-pile dolphins are installed. Impervious, cohesive soils allow excess pore water pressures to rise very high. Pore water pressure affects the shear strength of the soil and may reduce the load capacity of a dolphin until the pressure has dissipated. Some soils take three months or longer to dissipate excess pore pressure.

(2) Construction techniques.

(a) The center of the cluster, called a king pile (Figure 9-10, page 9-8), may be a single pile or a cluster driven vertically and wrapped to act as a unit. The other piles are driven in one or more concentric rings around the king pile, each battered towards the center. The king pile is longer than the others for use as a mooring post.

(b) When the king pile is made of a cluster, it is wrapped with at least six turns of 1-inch galvanized wire rope stapled to each pile at each turn.

(c) Two wrappings of 1-inch galvanized wire rope are used for the pile cluster. One wrapping is located near the top of the cluster and another about two-thirds the distance above mean low water.

(d) The piles are chocked and bolted together 2 feet above mean low water to further ensure the cluster will act as a unit.

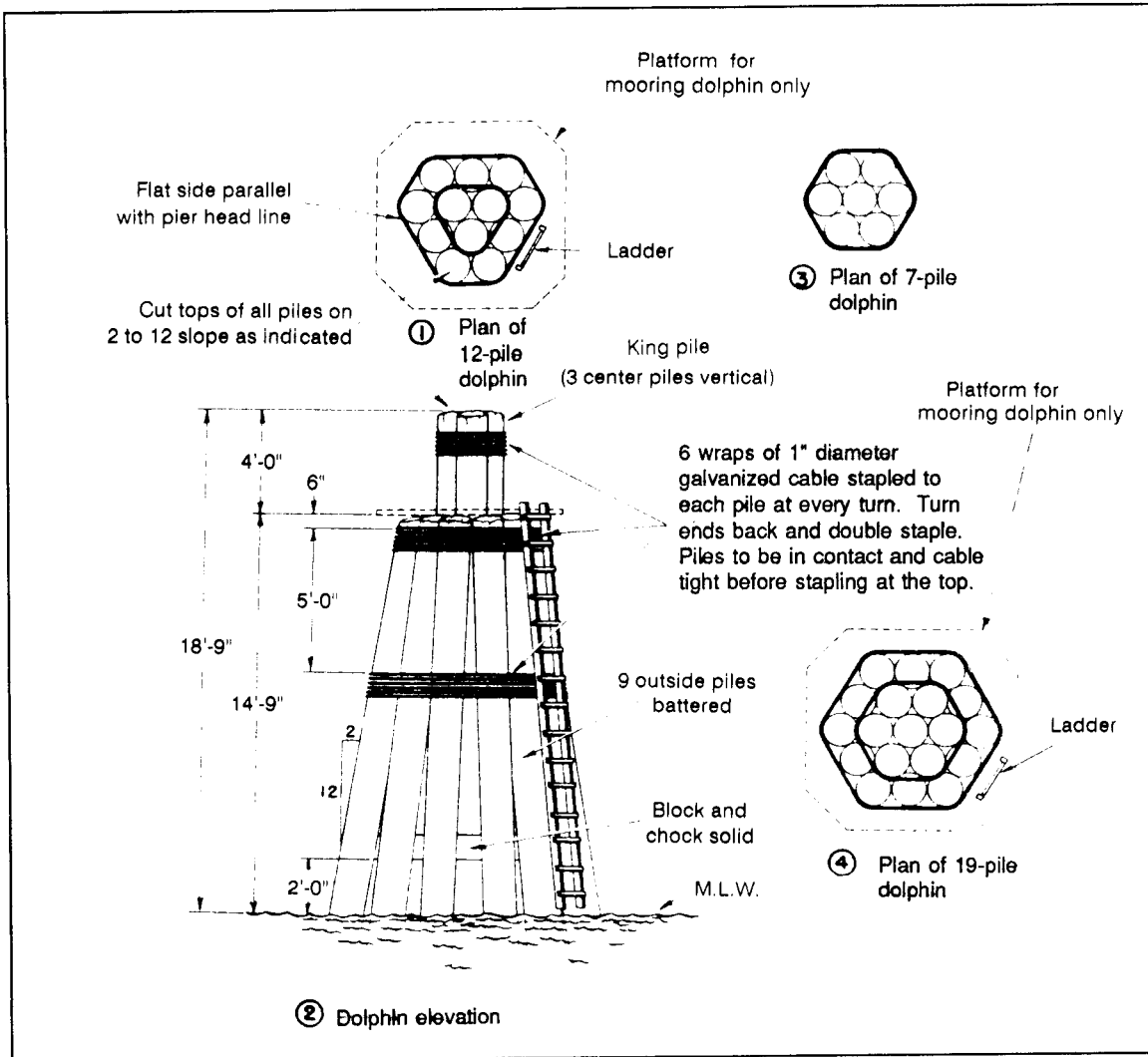

Figure 9-10. Timber Pile Cluster Dolphins

c. Uses.

(1) Dolphins sometimes extend the effective face of a wharf or jetty for mooring. A large cargo ship or tanker can discharge from a small wharf or jetty equipped with dolphins. However, the distance between extreme mooring dolphins must be at least as great as the length of the vessels.

(2) Dolphins may provide offshore moorings for ships worked by lighters. In such cases, they are installed well out of the harbor fairway.

(3) Turning dolphins warp or turn a ship around at the end of a pier.

(4) Dolphins serve as guide walls at ferry slips and at lock entrances.

(5) Dolphins can be used to keep vessels off structures not designed to accommodate their loads.

(6) Dolphins protect bridge piers from waterborne vessels, flood damage, and ice.

CHAPTER 10 FLOATING WHARVES

Both the US Army and Navy have floating equipment suitable for constructing floating wharves. The most promising equipment of each service is discussed below.

Section I. Army Equipment (Current TO&E)

The Army's floating bridge equipment was designed primarily for river-crossing operations. However, its rapid installation and large loading capacities make the equipment useful as floating causeways, rafts, ferries, and ramps used in ship-to-shore cargo transfer.

ALUMINUM PNEUMATIC FLOATING BRIDGE (M4T6)

a. Description. The M4T6 floating bridges and rafts (ferries) consist of aluminum balk decks on pneumatic floats. Figure 10-1 shows the structural assembly of an M4T6 float section. Manpower and equipment requirements for bridge and raft construction are discussed in FM 5-210.

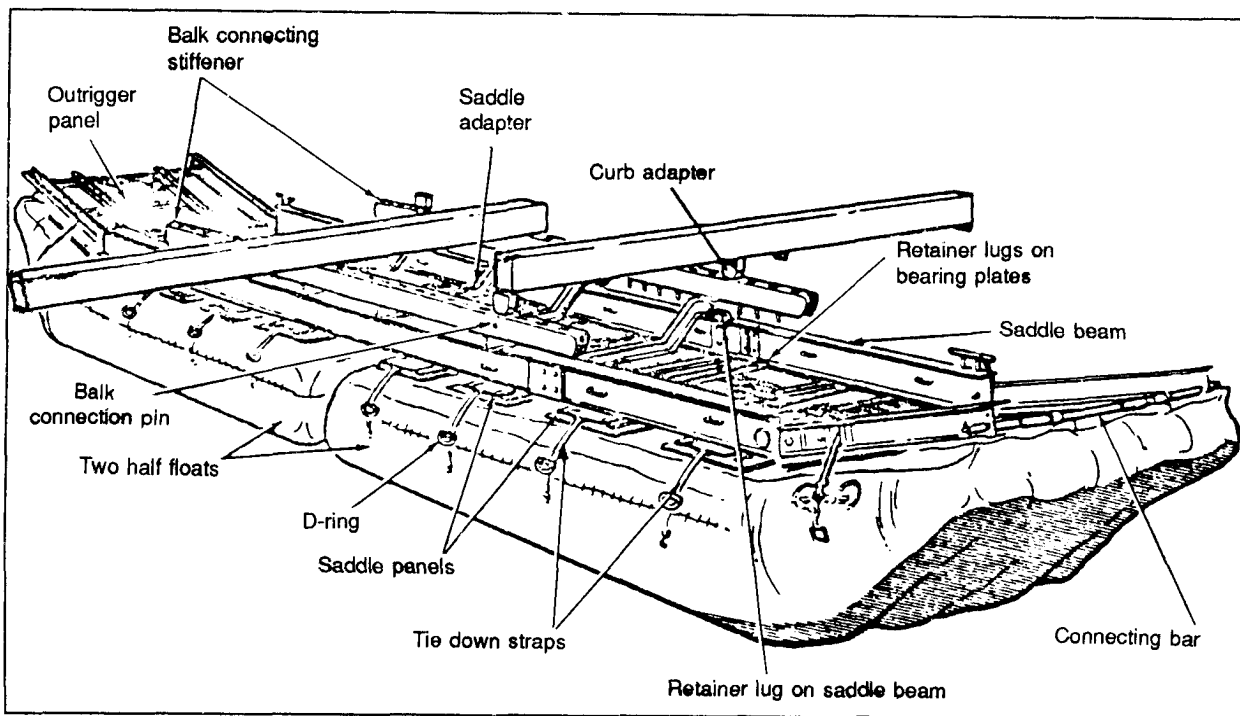

Figure 10-1. M4T6 Float Section

b. Port construction applications. Elements of the M4T6 may be used as causeways, lighters, and floating platforms for pile driving, dredging, and over-water crane operations.

c. Capabilities.

(1) Causeways. The M4T6 provides a one-lane roadway, 13 feet 10 1/2 inches wide. It can carry up to Class 50 wheeled loads in calm water. The loaded 5-ton tractor and 25-ton lowbed trailer combination is a Class 35 load. Rough water or strong currents may reduce the load capacity. Items such as tapered balk, raft ramps, and the 50-ton universal trestle may be used to make connections at the wharf and shore. A suitable anchorage system must be provided for all floating causeways.

(2) Lighters. Rafts from 87 to 103 feet long by 13 feet wide may be constructed to carry loads up to Class 60 in calm water. These rafts are powered by 19- or 27-foot bridge erection boats. For example, the completed four-float normal raft with an overhanging end ramp is 87 feet 1 inch long, and carries a Class 50 load in calm water when powered by one 27-foot bridge erection boat. Other raft capacities are listed in Table 10-1.

TABLE 10-1. Raft Classes, Dimensions, and Propulsion Requirements

Raft Construction	Overall Length	Wheeled Load Class in Calm Water	Propulsion Requirements*
4 float normal	87 ft 1 in	50	1
4 float reinforced	87 ft 1 in	50	1
5 float normal	102 ft 1 in	55	1
5 float reinforced	88 ft 1 in	60	1
6 float reinforced	103 ft 4 in	65	1
* Number of 27-foot bridge erection boats required.			

(3) Floating platforms. Rafts may also serve as floating platforms to support clam-shell or drag-line dredging, pile driving, and water crane and other construction operations. FM 5-210 details raft capacities.

d. Allocation.

(1) The engineer battalion of the armored, infantry, or mechanized division will receive four sets of either the M4T6 or Class 60 floating bridge when not equipped with the ribbon bridge.

(2) The corps engineer float bridge company will be issued five sets of either the M4T6 or Class 60 floating bridge when not equipped with the ribbon bridge.

(3) Bridge sets used in port construction come from depot stocks.

PNEUMATIC FLOATING STEEL (SUPERSTRUCTURE) BRIDGE (CLASS 60)

a. Description. Class-60 floating bridges and rafts (ferries) consist of flush-surfaced, steel-grid decks on the same 24-ton pneumatic floats as the M4T6. The deck panels are pinned together end-to-end to provide rigid connections. The deck can support a Class 65 vehicle load to approximately 10 floats with only minor deflection. See FM 5-210.

b. Port construction applications. Elements of the Class 60 float bridge equipment may serve like the M4T6.

c. Capabilities.

(1) Causeways. The deck width of the Class 60 float bridge is 13 1/2 feet between curbs (Figure 10-2). In calm waters it can carry up to Class 60 loads. As with the M4T6, it requires suitable anchorages and lighter loads in rough water.

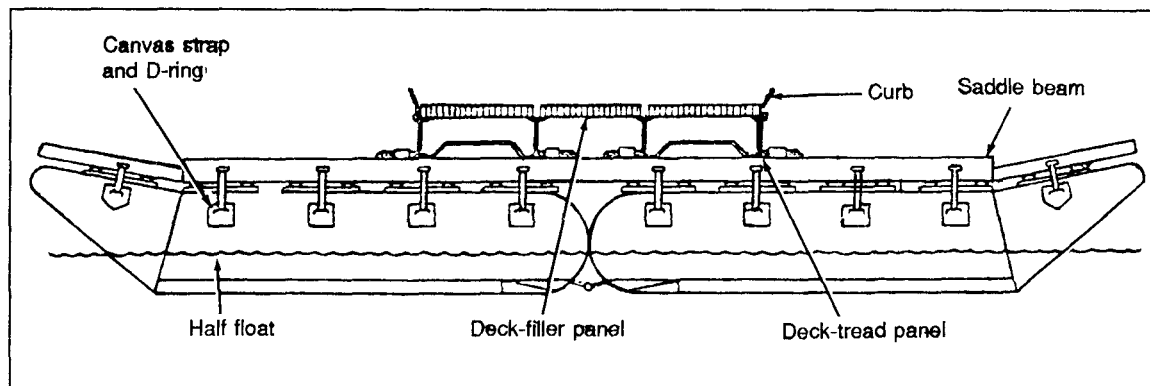

Figure 10-2. Causeway

(2) Lighters. The Class 60 raft is assembled in four- or five-float normal rafts or five- or six-float reinforced rafts. Table 10-2, page 10-4, gives the dimensions, classifications, and propulsion requirements (also see FM 5-210).

(3) Floating platforms. The discussion of the M4T6 used as a floating platform also applies to the Class 60 equipment.

d. Allocation. Same as the M4T6.

FLOATING BRIDGE (M4)

a. Description. The M4 floating bridge consists of aluminum balk decks supported by aluminum pontoons.

b. Port construction applications. As with the other floating bridge equipment, M4 floating bridges may be used in the port environment as causeways, lighters, and floating work platforms. See FM 5-210 and Table 10-2 for specifications.

TABLE 10-2. Class 60 Raft Classes, Dimensions, and Propulsion Requirements

Raft Construction	Overall Length	Length Available for Loading	Wheeled Load Class in Calm Water	Propulsion Requirement*
4 float normal	92 ft 5 in	51 ft	40	1
5 float normal	107 ft 5 in	66 ft	50	1
5 float reinforced	92 ft 5 in	51 ft	55	1
5 float reinforced (with one short deck bay)	83 ft 1 in	43 ft 9 in	60	1
6 float reinforced	92 ft 5 in	54 ft	65	1

* Number of 27-foot bridge erection boats needed to satisfy propulsion requirement.

c. Capabilities.

(1) Causeways. The roadway width of the M4 float bridge is 13 feet 10 1/2 inches. It can support Class 60 loads when constructed in normal configuration and Class 100 loads using reinforced construction (Figure 10-3). These classes apply to operation in calm water. They must be reduced for rough water or strong currents.

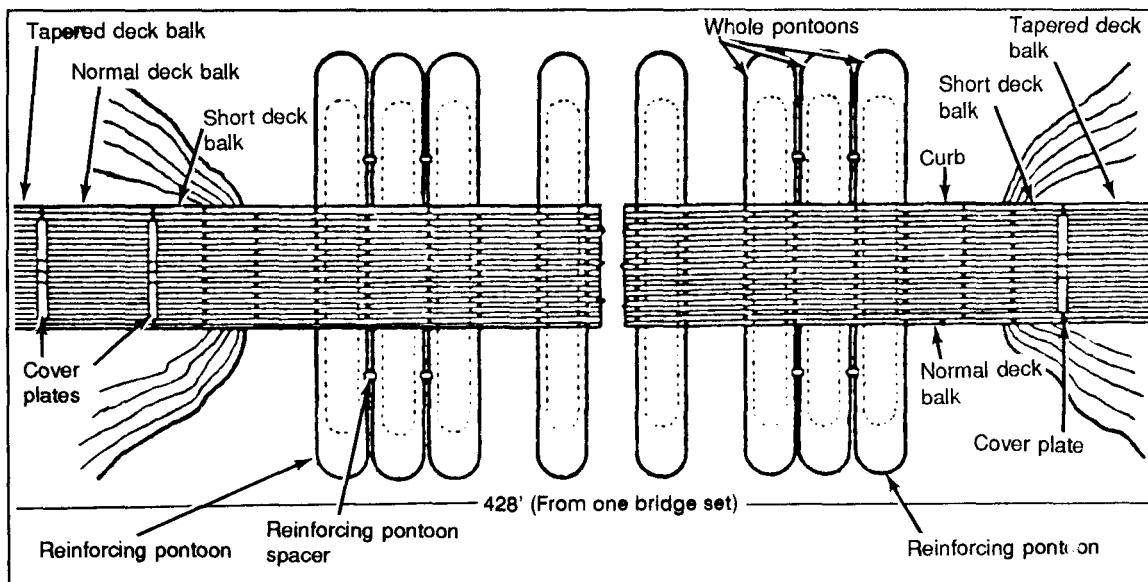

Figure 10-3. Causeway Using Reinforced Construction

(2) Lighters. The M4 may be assembled in 4-, 6-, and 7-pontoon configurations or in shorter rafts of 4 or 5 pontoons. Table 10-3 gives basic M4 characteristics.

TABLE 10-3. M4 Raft Classes, Dimensions, and Propulsion Requirements

Raft Construction	Overall Length	Wheeled Load Class in Calm Water	Propulsion Requirements
4 pontoon	87 ft 3/4 in	50	1
6 pontoon, reinforced	87 ft 3/4 in	70	1
7 pontoon, reinforced	87 ft 3/4 in	85	1
4 pontoon, shortened	73 ft 8-3/4 in	50	1
5 pontoon, shortened	73 ft 8-3/4 in	70	1

** Number of 27-foot barge erection boats needed to satisfy propulsion requirement.*

(3) Floating platforms. The earlier discussion concerning use as floating platforms also applies to M4 equipment.

d. Allocation. The M4 bridge is not normally issued to units as organic equipment.

Section II. Navy Equipment

Ruggedness, convenience of assembly, and flexibility make Navy pontoon gear useful as floating wharves, wharf approaches, floating dry docks for small craft, barges, and many other purposes. This gear uses specially designed, internally reinforced, welded steel cubes, officially called Navy lightered (NL) pontoons.

The Navy has used two series of pontoons widely: the T-series, currently being phased out, and the P-series, now in use. The two series are not readily interchangeable due to differences in width and bolt-hole spacing. This manual discusses only P-series pontoons.

P-SERIES PONTOONS

a. General. There are five types of P-series pontoons, designated PI through P5. All withstand an internal pressure of 20 pounds per square inch. All have decks designed for the American Association of State Highway and Transportation Officials (AASHTO) H-20 loadings--32,000 pounds/axle.

b. Uses. Pontoon units are usually configured in one of five ways. They are used as: pontoon barges and tugs, floating drydocks, bridge units, or pontoon wharves. These uses are discussed in more detail in the following section.

a. P1 Pontoon. The P1 pontoon (Figure 10-4) has a 5 foot 3/8 inch by 7 foot deck. The sides are 5 feet 3/8 inch high. The side, end, deck, and bottom plating are 3/16 inch thick. The P1 is the most common pontoon in the P-series. Every structure of the pontoon system uses it.

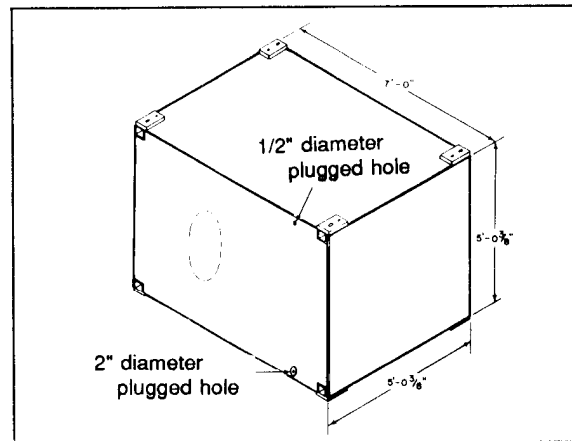

Figure 10-4. P1 Pontoon

b. P2 Pontoon. The P2 pontoon (Figure 10-5) has the same depth as the P1. But it has a 7-foot square deck and a straight-line sloping bow. The side, end, and deck plates are 3/16 inch thick, and the bow plate is 3/8 inch thick. The P2 pontoon is used on the bow and stern of various pontoon structures.

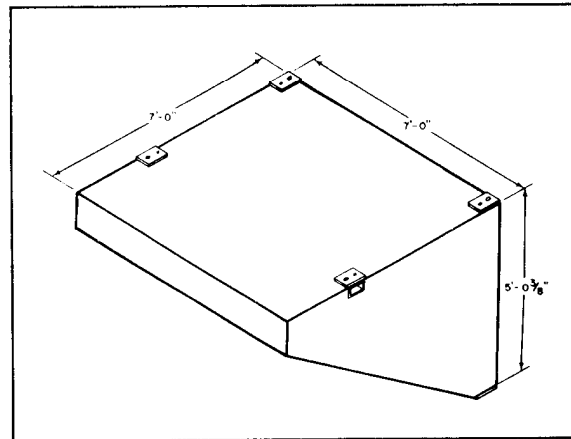

Figure 10-5. P2 Pontoon

c. P3 Pontoon. The P3 pontoon (Figure 10-6) has an inclined deck 5 feet 1 3/4 inches long and 7 feet wide. The deck slopes from 4 feet 11 3/8 inches to 3 feet 8 1/4 inches high. The bottom is horizontal. All plating is 3/16 inch thick. The sloping deck is fitted with five 1-inch square ribs 5 feet 5 inches long. They are evenly spaced and secured by welding. A covering of nonskid paint is applied between the cleats. The P3 is used with the P4 to form a sloped ramp for causeway ends and ramp barge bows.

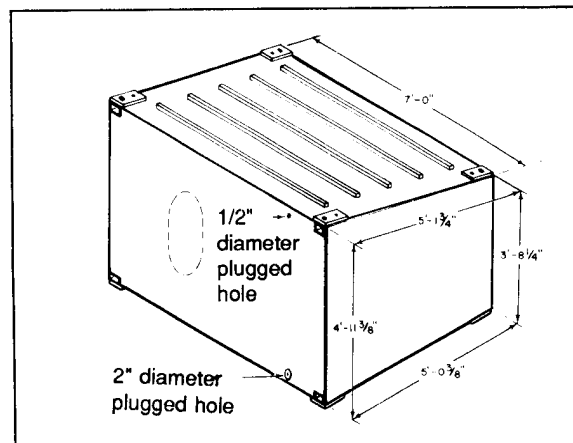

Figure 10-6. P3 Pontoon

d. P4 Pontoon. The P4 pontoon (Figure 10-7) has a deck 5 feet 1 3/4 inches long and 7 feet wide. The slope is the same as the P3 pontoon. The aft end is 3 feet 6 inches high; the forward end, 1 foot. The bottom is horizontal for 8 inches on the aft end, then slopes upward. The deck, side, and back plates are 3/16 inch thick. The bottom or bilge plate is 3/8 inch thick. Five evenly spaced, 1-inch square ribs are welded to the sloped deck. A coat of nonskid paint is applied between cleats. Used with the P3, the P4 forms a continuous ramp for causeway ends and ramp barge bows.

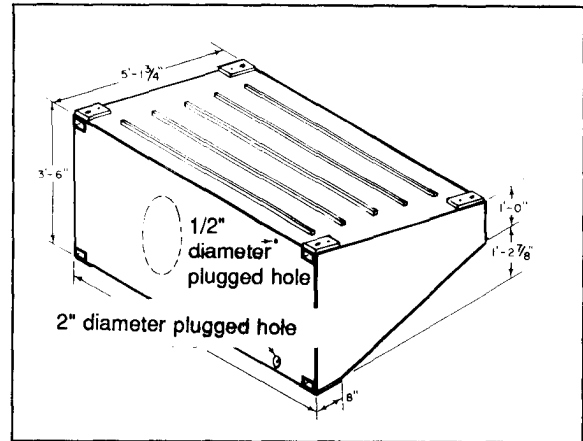

Figure 10-7. P4 Pontoon

e. P5 Pontoon. P-series 3 by 15 pontoon causeways are connected end-to-end by alternate P5M (male) and P5F (female) pontoons (Figure 10-8). As barge sections they serve wharves where end-to-end connection is required. These pontoons are constructed by welding hinge connectors to P2 pontoons. They are then assembled in male and female sequence, forming causeways of any required length. These pontoons may also be used to enlarge or extend wharf structures. The center of the P5F hinge is made from a 8-inch pipe. The center of the P5M hinge is made from a reinforced 6-inch pipe. When jointed, these two parts resist the torsion, compression, and vertical shear forces in the joint.

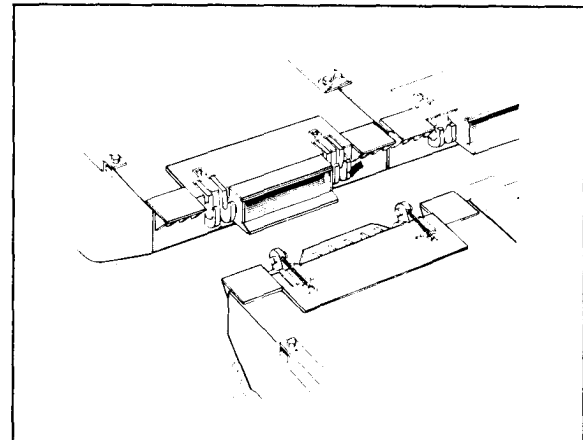

Figure 10-8. P5 Pontoon

USES FOR P-SERIES PONTOONS.

a. Pontoon barges. The standard barge units (3 by 7, 4 by 7, 3 by 12, 4 by 12, 5 by 12, 6 by 18, and 10 by 30) are constructed with P-series pontoons (Table 10-4, page 10-8). Use and limited fabrication details follow for each barge:

(1) 3 by 7 pontoon barge.

(a) Use. This pontoon barge is a general-purpose structure employed in lighters and ferrying. It can also be used as a towed cargo transport. The barge can be self-propelled with the addition of a propulsion unit on the end without fenders. Table 10-5 shows barge capacity and draft.

(b) Construction. Engineers can build 3 x 7 pontoon barges in strings assembled in water. The barge consists of three strings, of five P1 pontoons each with a P2 sloping bow pontoon at each end.

TABLE 10-4. Weights and Volumes of P-Series Pontoons

P-Series Pontoon Type	Weight (lb)	Volume (cu ft)
P1	2,060	175
P2	2,700	160
P3	2,200	138
P4	1,950	103
P5F and P5M	3,200	160

TABLE 10-5. Size, Capacity and Draft of P-Series Pontoons

Type	Approximate Weight* (tons)	Capacity (tons)	Deck Size (feet)	Light Draft (inches)	Loaded Draft (inches)
3 X 7	31.5	50	21 X 43	20	45
3 X 12	54.0	85	21 X 73	20	45
4 X 7	42.0	65	28 X 43	20	48
4 X 12	72.0	100	28 X 72	20	44
5 X 12	90.0	125	35 X 72	20	44
6 X 18	162.0	250	43 X 107	20	48
10 X 30	450.0	800	71 X 177	20	50

* Used pontoon structures will weigh more because of water accumulated in the pontoons.

(2) 4 by 7 pontoon barge.

(a) Use. This pontoon barge is similar in all respects to the 3 by 7 barge except it is one string wider. Although it is used chiefly for lighters, it is suitable for other transportation tasks as well (Table 10-5). When equipped with a propulsion unit, the barge can move at speeds of 4 to 6 knots, depending upon the load carried. It can ground and back off the beach in dangerous tides and surf.

(b) Construction. Pontoon string construction details are the same as for the 3 by 7 barge.

(3) 3 by 12 pontoon barge.

(a) Use. This barge, a ramp barge, is used for transporting cargo and equipment in amphibious operations. The sloping bow-end with ramps attached (Figure 10-9) permits beaching the barge under its own power, to unload tractors and equipment to form a causeway pier. Four of the barges can be side-loaded on a landing ship, tank (LST) for side-carry to the assault area, or the barge can be loaded in the well deck of a landing ship, dock (LSD) or deck-loaded on an LST. Table 10-5 shows size, capacity, and draft.

(b) Construction. Engineers can construct 3 by 12 barges by building and assembling the strings in the water. The entire structure can also be assembled and launched as a unit from a dock. The barge has three strings, each consisting of nine P1 pontoons with one P2 pontoon on the stern and one each of the P3 and P4 sloping-deck pontoons on the bow end.

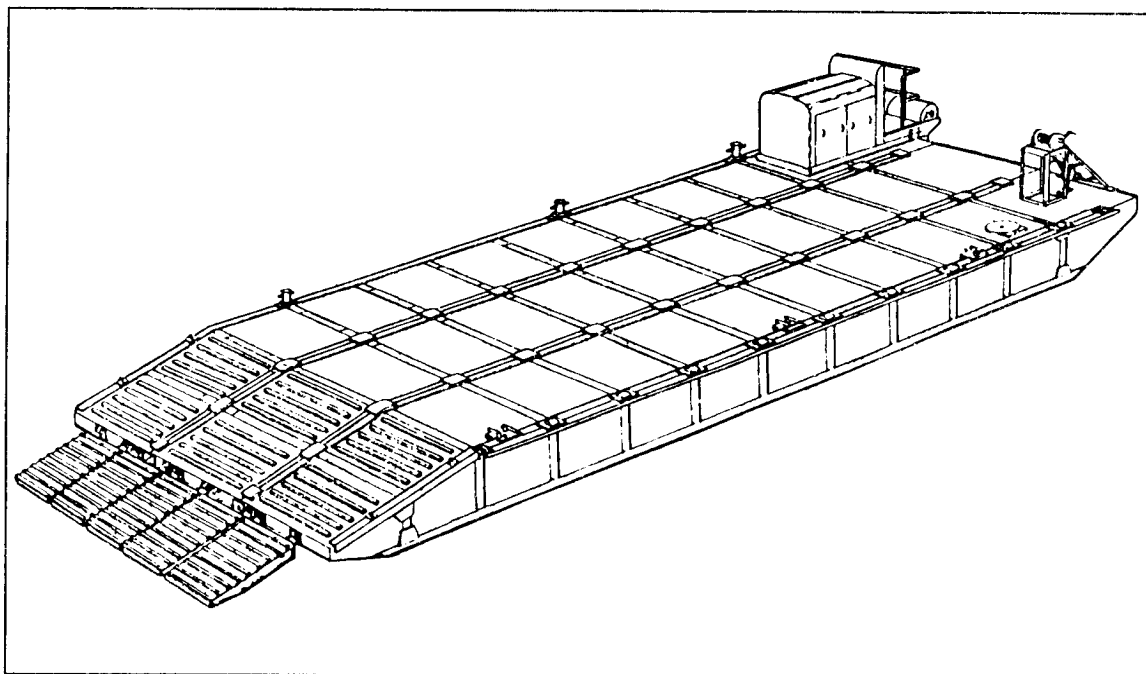

Figure 10-9. Sloping Barge with Ramp Attached

(4) 4 by 12 pontoon barge.

(a) Use. These barges resemble 4 by 7 barges in length and capacity. They also have the same accessories. A general-purpose lighter, the 4 by 12 barge is either towed or self-propelled when propulsion units are added. With accessories it converts to a gate vessel.

(b) Construction. Built and assembled in strings in water, the 4 by 12 barge has four strings of ten P1 pontoons with one P2 pontoon on each end.

(5) 5 by 12 pontoon barge.

(a) Use. This barge is one string wider than the 4 by 12 barge but is similar in all other respects. A crawler crane with a lifting capacity ranging from 20 tons at a 12-foot radius to 7 tons at 55 feet can be mounted to its deck. It can serve as a general-purpose structure or as a self-propelled lighter, after a propulsion unit is added. Figure 10-10 illustrates a typical 5 by 12 pontoon barge.

(b) Construction. Construction of the 5 by 12 barge (Figure 10-10) is the same as for the 4 by 12, except for the additional string.

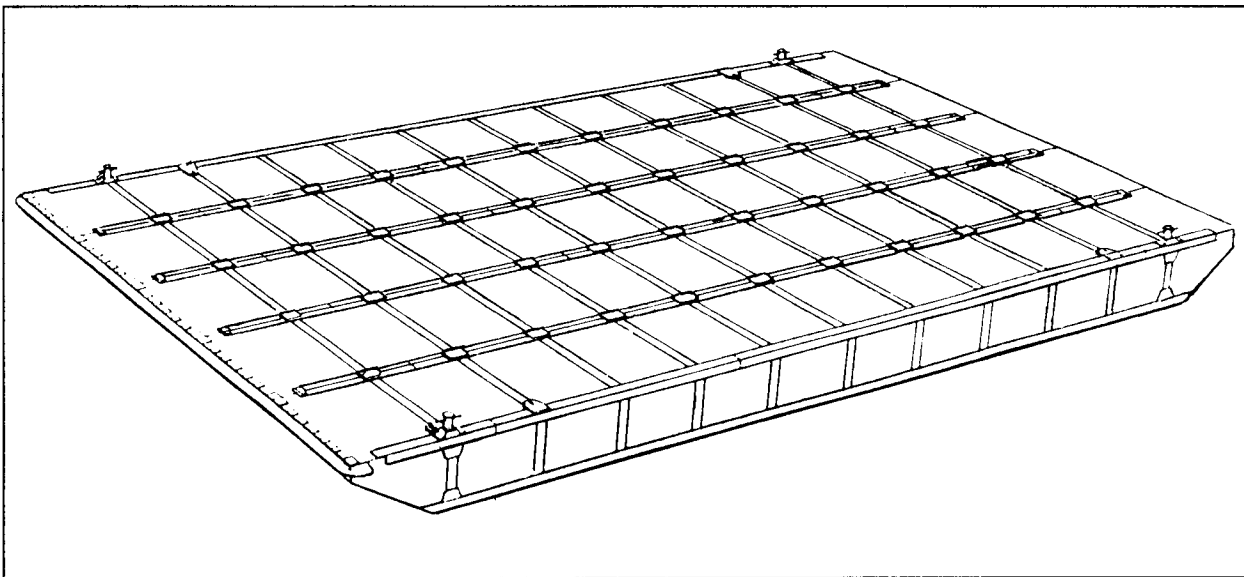

Figure 10-10. 5 by 12 Pontoon Barge

(6) 6 by 18 pontoon barge.

(a) Use. This is the second largest barge in the P-series pontoon system. With propulsion units, it can be used as a lighter, transporting loads up to 250 tons. Other accessories and equipment can convert the barge into a 1,500-barrel fuel storage barge. Installing heavy-duty hinges converts the barge into a wharf. As a barge it can be used for outfitting and repairing smaller structures placed on its deck. The barge comes equipped with a 750-pound mooring anchor, anchor hoist, and winch.

(b) Construction. Each of six strings is made of ten intermediate P1 rectangular pontoons and two sloping bow P2 pontoons (Figure 10-11). They are assembled, launched, and jointed in water. However, heavier angles are used centrally in the strings to compensate for greater forces imposed on larger structures.

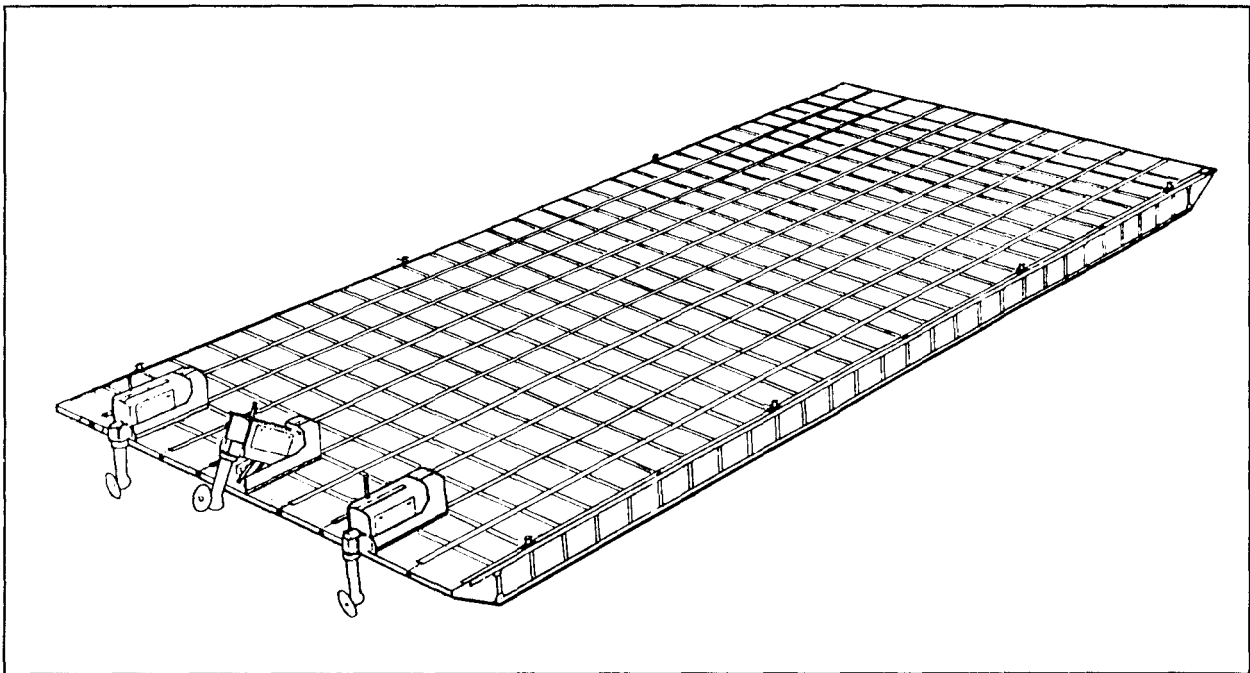

Figure 10-11. Assembled 10 by 30 Pontoon Barge

(7) 10 by 30 pontoon barge.

(a) Use. The largest barge in the pontoon system, it was developed for mounting a 100-ton derrick. The barge has other uses. With propulsion units attached, it can serve as a lighter to transport approximately 800 tons of cargo at one time from ship to shore or dock (Table 10-5, page 10-8). The barge can also serve as a pier or wharf. Heavy hinges allow it to act as an extension to an existing pontoon wharf.

(b) Construction. The barge is built from 10 strings, each made of 28 intermediate P1 rectangular pontoons and two sloping bow P2 pontoons. Erection procedures are similar to those used for other pontoon structures. All assembly angles are 8 by 8 by 12 inches.

b. Pontoon tugs. Tugs are barges equipped with outboard propulsion units and other accessories. P-series tugs are widely adaptable for towing, causeway tending, placing and retrieving anchors, salvage, assisting in the installation and recovery of fuel systems, and other services. The 3 by 4 pontoon tug (Figure 10-12) and the 3 by 14 warping tug are the most common.

(1) 3 by 4 pontoon tug.

(a) Use. This pontoon tug has one outboard propulsion unit mounted on the center string. That string is assembled forward of the outboard strings to provide protection at the stern for the propeller of the propulsion unit. The tug has a 150-pound mooring anchor and gear. The tug tows other barge assemblies that are not self-propelled.

(b) Construction. These pontoon tugs consist of three strings. Each string includes two P1 rectangular pontoons with P2 sloping bow pontoons on either end. The tug can be built of strings launched and assembled in the water or can be assembled and launched complete from a deck.

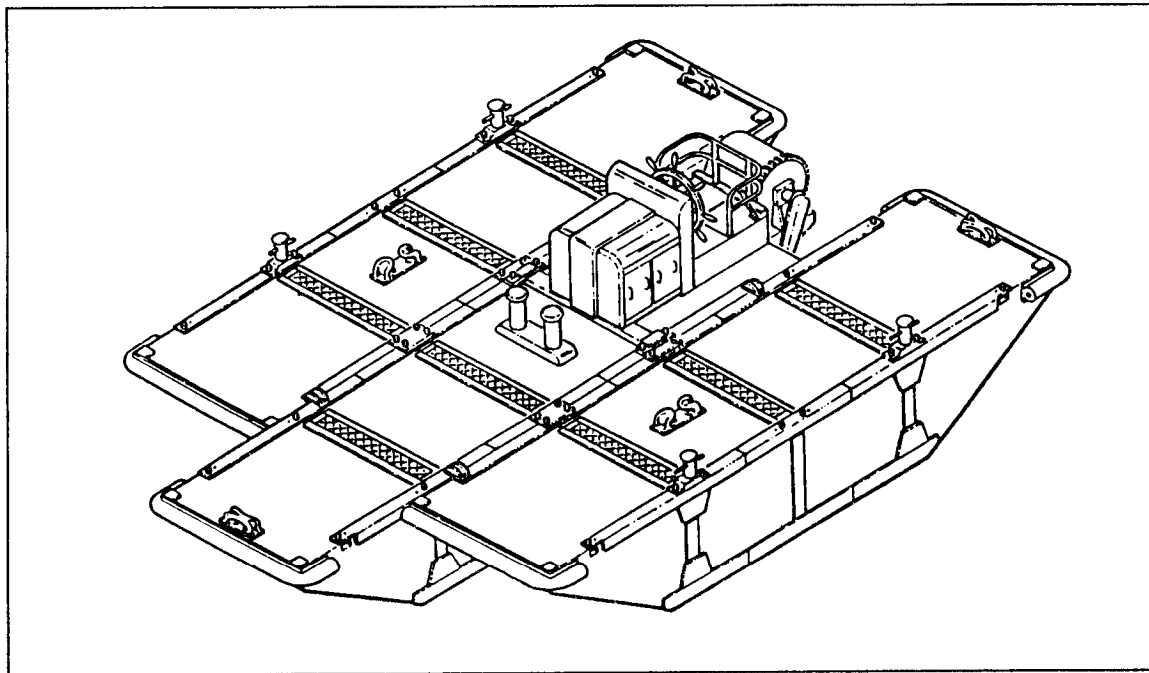

Figure 10-12. 3 by 4 Pontoon Tug

(2) 3 by 14 Warping Tug.

(a) Use. This warping tug is a barge adapted for LST side carry and equipped with two outboard propulsion units. The warping tug can be used to pick up small landing craft sunk in the surf or shallow water, salvage anchors, and install causeways. Other uses include placing and retrieving anchors used when establishing causeway piers, and installing standard tanker moorings for fuel systems (TM 520).

(b) Construction. This warping tug can be built from strings assembled in the water. It has three strings of 14 pontoons each. The port and starboard strings each include 12 rectangular P1 pontoons with one sloping bow P2 pontoon at each end. The center string is made up of 13 P1 pontoons with one P2 pontoon at the bow and an anchor housing attached to the stern pontoon. Figure 10-13 shows an assembled 3 by 14 warping tug with a warping tug A-frame.

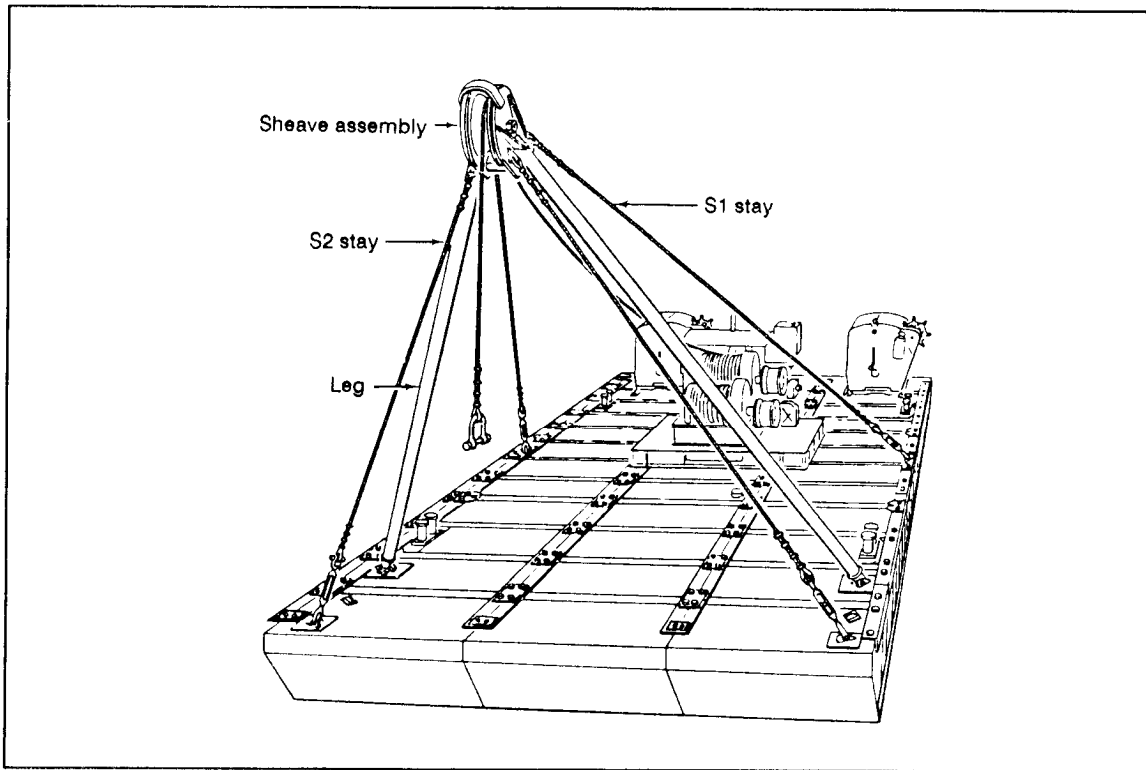

Figure 10-13. Assembled 3 by 14 Warping Tug with A-Frame

c. Floating drydocks.

(1) Floating pontoon drydocks consist principally of a main, wharf-like deck and vertical side towers constructed of P-series pontoon units. They are submerged by admitting a controlling amount of water into the deck pontoon and raised by expelling the water with compressed air. The tower pontoons act as stabilizers to keep the drydock level when the deck is under water. Drydocks require 18 feet of water to submerge the decks 12 feet, the maximum safe depth. They should be moored in sheltered, quiet water 18 to 20 feet deep. The area should have a smooth bottom, without large rocks or other obstacles.

TABLE 10-6. 4 by 15 and 6 by 30 Pontoon Drydock Data

Physical Characteristics	Size by Pontoons	
	4 by 15	6 by 30
Capacity (long tons)	100	400
Nominal length of deck (ft)	86	173
Nominal width of deck (ft)	29	43
Light draft (in)	28	25
Loaded draft (in)	52	52
Draft over deck (ft)	13	13
Approximate submerging time (min)	15	30
Approximate raising time (min)	20	35

(2) The Navy Advanced Base Functional Component Program has two sizes of pontoon drydocks. They are identified as the 4 by 15 (100-ton capacity) drydock and the 6 by 30 (400-ton capacity) drydock. Table 10-6 gives additional data on pontoon drydocks. Figure 10-14 shows a 4 by 15 pontoon drydock.

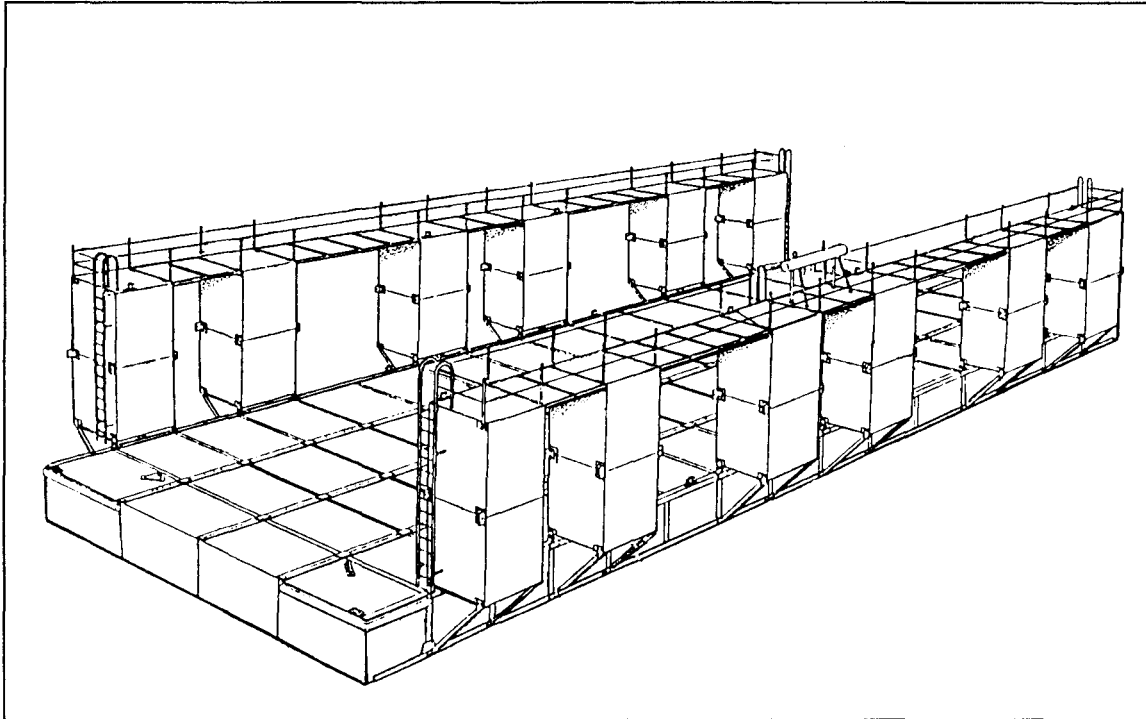

Figure 10-14. 4 by 15 Pontoon Drydock

d. Bridge units. Strings of pontoons may span a waterway or cross a swampy area. More often, bridge units connect pontoon wharves with the shore. Bridge units are unsuitable as unsupported bridges except in emergencies. P-series units classifiable as bridge units are as follows:

(1) 4 by 18 pontoon bridge. This pontoon bridge serves mainly in bridging from the shore to a pontoon wharf. The complete structure weighs 108 tons. The deck area is approximately 107 by 28 feet, with four strings of 16 rectangular P1 pontoons with P2 sloping bow pontoons at each end. Strings are assembled and launched, then joined in the water.

(2) 2 by 6 abutment. Although not actually a bridge unit, the 2 by 6 abutment is used at the shore ends of bridge units. It anchors these ends and serves as a ramp for loading or unloading ships. It has two strings of six P1 rectangular pontoons with a deck area of 35 by 14 feet. It weighs 18 tons and was developed for use as shipping and launch structures at advanced bases.

(3) 3 by 15 causeway (Figure 10-15). These causeway sections can serve as bridge units. They can be connected to other causeway sections or to wharves. They provide room for trucks and cranes. They also serve as piers to unload small craft carrying bulk cargo. Figure 10-15 shows a 3 by 15 causeway section.

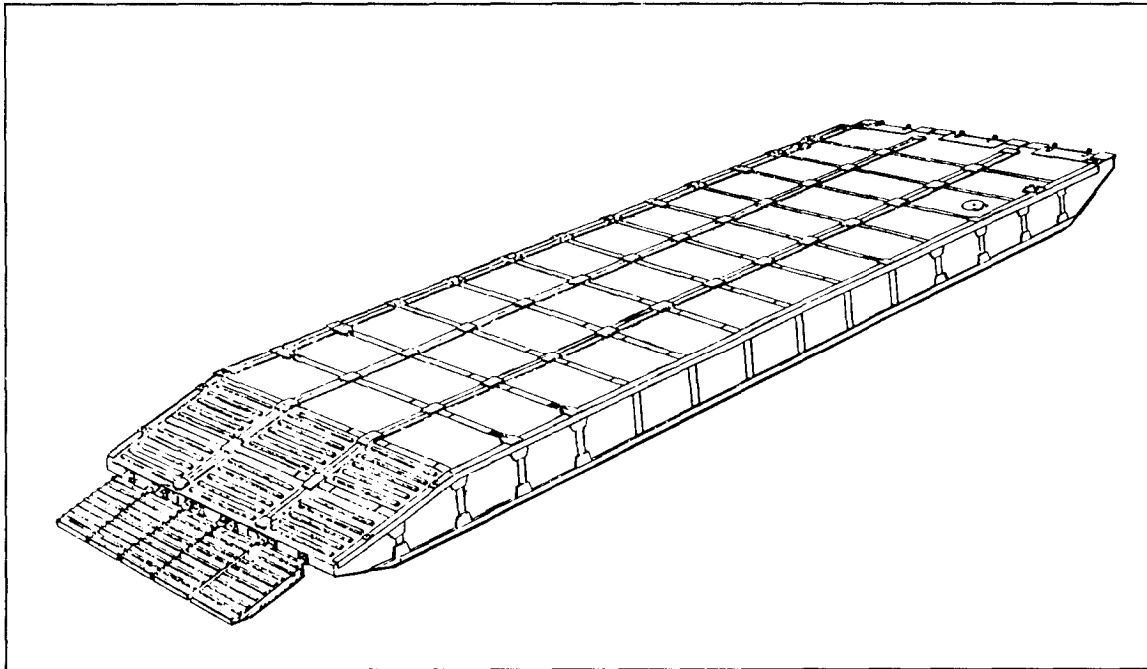

Figure 10-15. In-Shore Causeway Section

e. Pontoon wharves. Pontoon wharves are designed to serve general and/or break-bulk cargo requirements in the operational area. Connected to the shore by pontoon bridges, they are moored offshore in water deep enough for cargo vessels. Two sizes of wharves are standard within P-series equipment, 5 by 12 and 6 by 72 wharves. The bridges (causeways) connecting the wharves to the shore are an important part of the installation. Different arrangements are possible. Three such arrangements, each applicable to both 5 by 12 and 6 by 72 wharves, are shown by Figures 10-16 through 10-18. Each installation uses a 4 by 18 pontoon bridge connected to the wharf by heavy-duty hinges at the offshore end and to a 2 by 6 abutment unit filled with sand at the inshore end. Cable moorings anchor both the wharf and its connecting bridges to the shore. Cable is used to anchor any one of the three types of bridge-and-wharf assemblies shown. In each of these arrangements, the wharf is kept fixed by a series of encircling pile dolphins. The offshore location of the wharf depends on the slope of the sea bottom and the tidal range. If deep water lies a short distance out and the tidal range is small, the wharf may be close to the beach and may require only one section in each connecting bridge. Shallow water for some distance or a great tidal range may require two or more bridge sections between the wharf and the shore.

(1) 5 by 12 pontoon wharf. This pontoon wharf is five strings wide and twelve pontoons long. It has a deck area of 68 by 35 feet. Assembly procedures for the strings and wharf are the same as for other pontoon structures. Moorings to the shore are made with four 150-pound mooring anchors and eight 90-foot lengths of 5/8-inch anchor chain. Heavy-duty hinges connect the wharf to the shore bridges.

(2) 6 by 72 pontoon wharf. The 6 by 72 pontoon wharf is 431 feet long by 42 1/2 feet wide. It has four standard 6 by 18 barges joined (without propulsion units) longitudinally. These are connected to the shore with 4 by 18 pontoon bridges. The 6 by 18 barge units used to make the 6 by 72 wharf are modified by installing alternate P5F and P5M end-connection pontoons on the ends of the barge that connect with other barges.

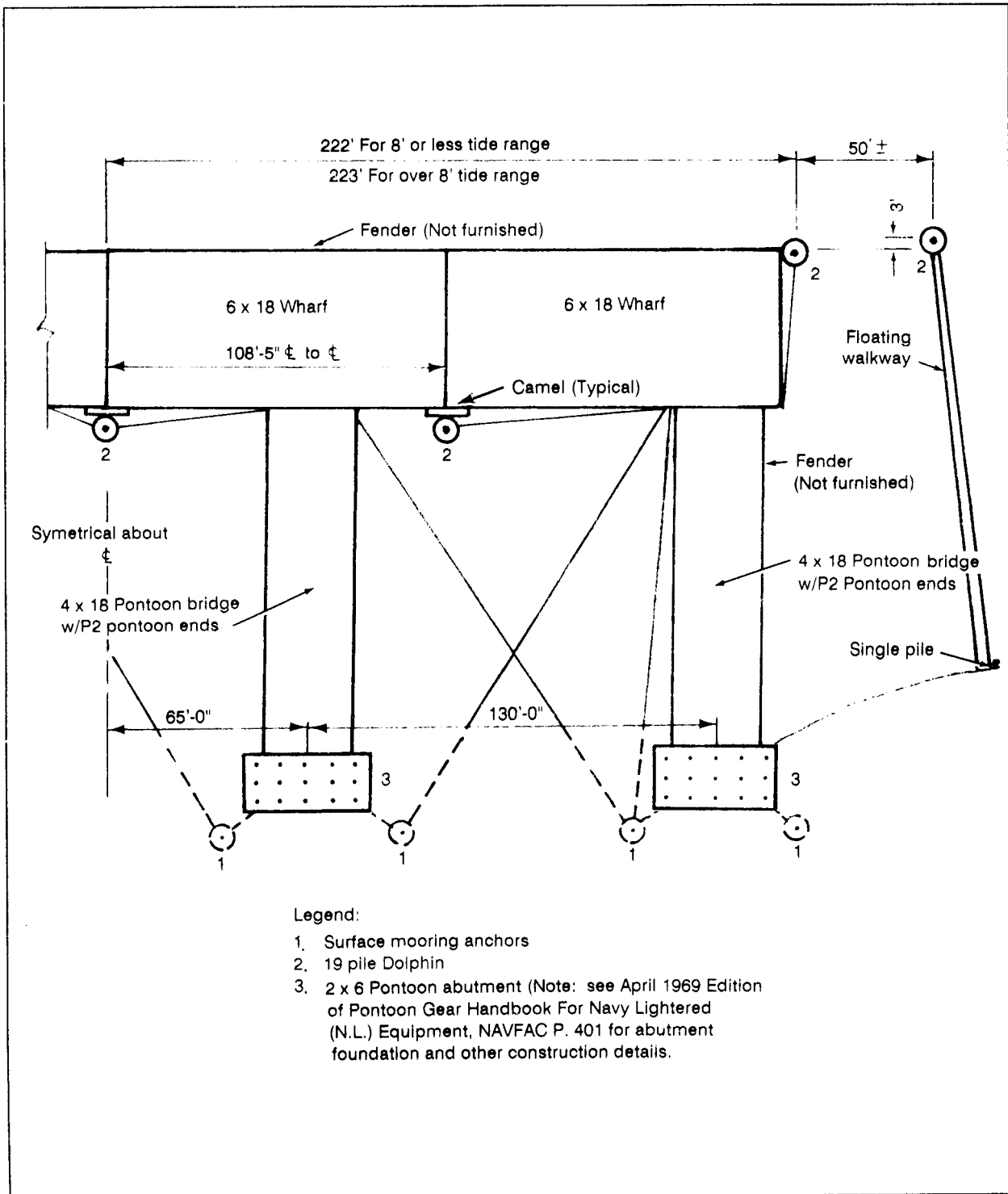

Figure 10-16. Causeway Arrangement 1 (with Pontoon Wharf)

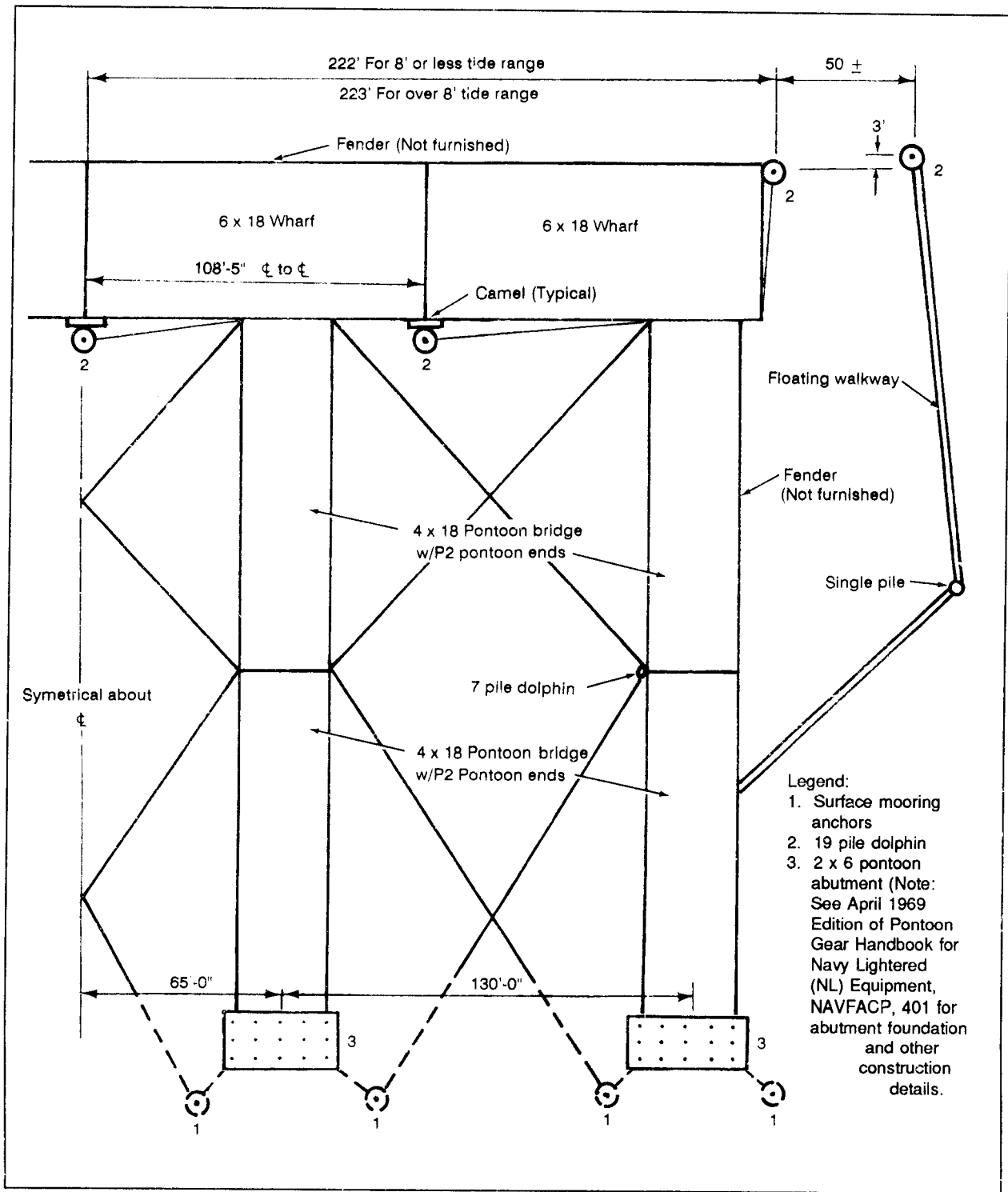

Figure 10-17. Causeway Arrangement 2 (with Pontoon Wharf)

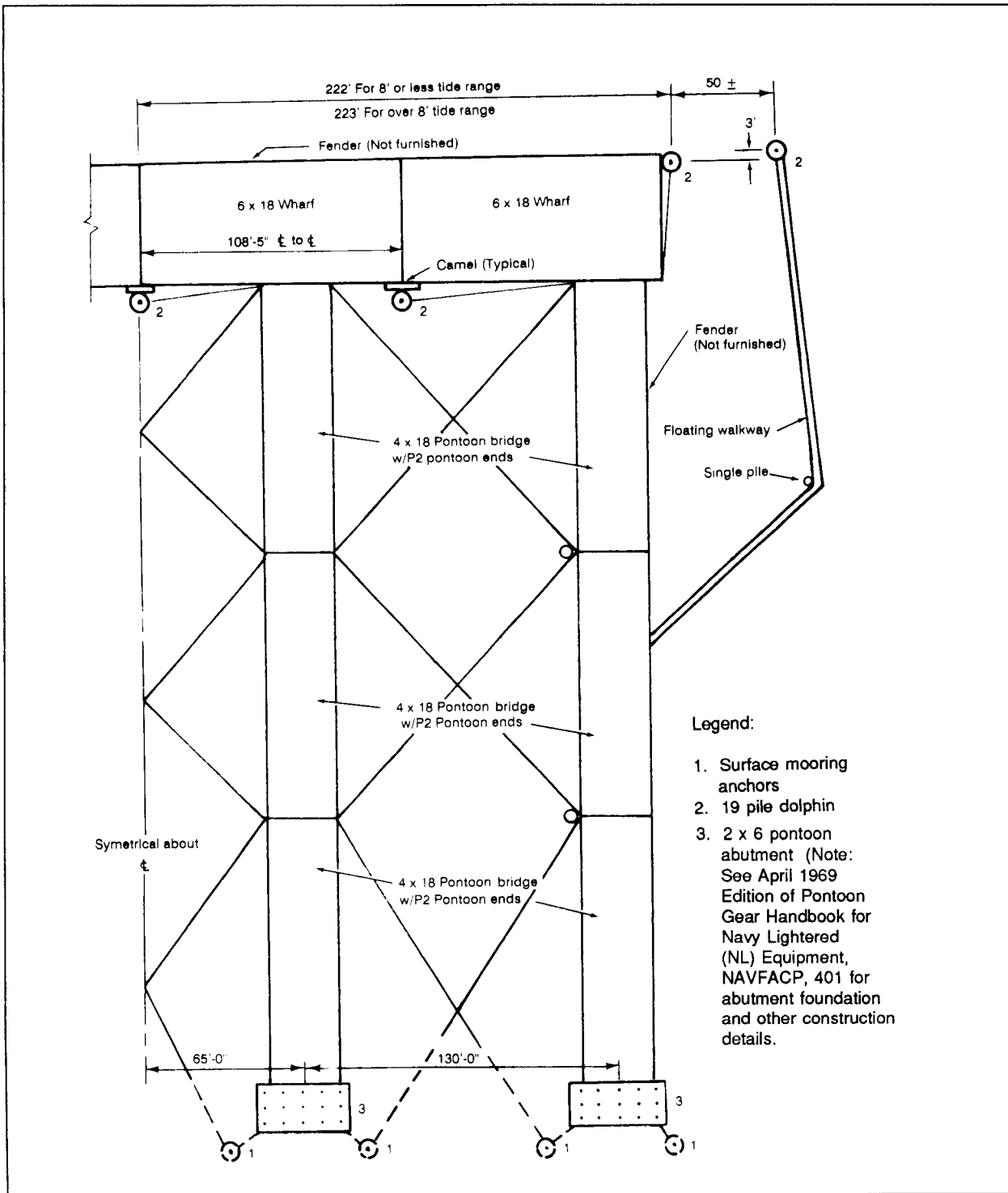

Figure 10-18. Causeway Arrangement 3 (with Pontoon Wharf)

CHAPTER 11 SELF-ELEVATING BARGE PIERS

Section I. DeLong Barges

BACKGROUND

a. The Army has two sizes of self-elevating barges. They are manufactured by the DeLong Corporation and are known as the "A" and "B" units of the DeLong system.

(1) The "A" barge is 300 feet long, 80 feet wide, and 13 feet deep. It is supported by ten 6-foot diameter caissons and ten 500-ton capacity jacks.

(2) The "B" barge is 150 feet long, 60 feet wide, and 10 feet deep. It is supported by six 6-foot diameter caissons and six 500-ton capacity jacks.

(3) In addition, two identical sizes from the Marathon-LeTourneau (M-L) Corporation have been recommended for adoption by the military.

b. Installation and erection procedures for "A" and "B" DeLong barges are outlined in the DeLong jacking systems manual, "Self-Elevating Barge." Therefore, this field manual omits them. It includes all other pertinent information, including fabrication method, design deck loading, supporting systems, operational requirements, past uses and basic considerations in site selection and shore connections.

TYPES

a. Barge. The "A" and "B" DeLong barges are honeycomb-like, welded-steel, box-girder structures consisting of plates and stiffeners. They support a uniform live deck-load of 500 to 600 pounds per square foot. The barges are divided into watertight compartments to maintain safe subdivision in case of towing accidents. Additional watertight compartments provide storage for fresh water and fuel. Each compartment can be entered from the deck through a manhole. The barge has a nonskid deck of 4 by 12 inch wood planking.

b. Caissons. Each caisson is essentially a welded steel pipe 6 feet in diameter and 140 feet long weighing 80 tons. The wall is normally 1 1/2 inches of American Society for Testing and Materials (ASTM) A-131 steel. To ensure lateral stability, a steel diaphragm is positioned 19 feet from the bottom end of each caisson to develop end bearing strength after sufficient penetration. Another diaphragm is fitted 40 inches from the top end. This allows the caisson to float. The load-carrying capacity of the pier and the depth of penetration of the caissons depend on both the foundation soils and the unbraced length of the caissons. Foundation soils of consolidated clays and nonplastic materials are best. Impenetrable, organic, or highly plastic soils are unsuitable.

c. Air jacks and controls.

(1) Air jacks. An air jack is a barrel-shaped steel cylinder approximately 10 1/2 feet high and 10 feet in diameter. It can raise 500 tons at a nominal rate of 12 feet per hour with a stroke of 12 inches. One jack is provided for each caisson well in the barge unit. The top of the jack is guided by four tie-rods anchored to the deck of the barge. The tie-rods are equally spaced around the air jack. Air jacks are secured to the deck using tie-rods during transit to minimize work at the preparation site.

(2) Controls. A master control panel (Figure 11-1) allows controls to operate simultaneously on all caissons. They can be operated individually by smaller control panels (Figure 11-1) connected by flexible hoses to the three-way valves on each jack. The control valves on each panel regulate the functions of the four major jack components as follows:

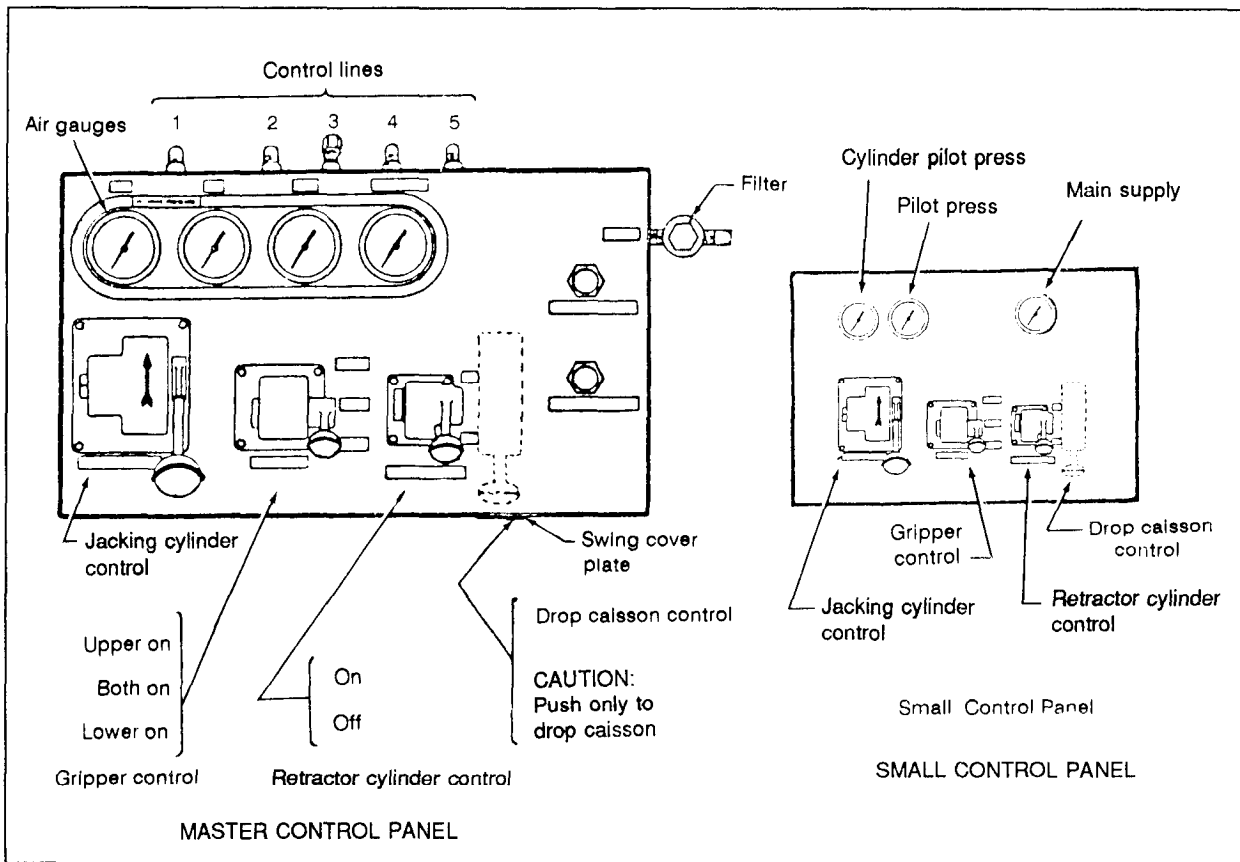

Figure 11-1. Control Panels

(a) The jacking control cylinders govern the jacking cylinders around the jack. When the control valve is "on," compressed air is admitted into the cylinder, causing the jack to lift.

(b) The retractor cylinder control regulates two retractor cylinders, spaced 180 degrees apart on the jack. When "on", this valve allows compressed air to enter the retractor cylinders, causing the jack to close.

(c) The upper and lower grippers are in the upper and lower portions of the jack. Each set of grippers has six rubber tubes inside the jack. Two controls regulate their function: the gripper control and the drop caisson control. The gripper control has three positions. In the "lower on" position, the lower grippers inflate and secure the lower portion of the jack to the caisson. The "both on" position secures the entire jack to the caisson. The "upper on" position secures the jack's upper half to the caisson. The "drop caisson" control overrides the gripper control and deflates both upper and lower grippers, allowing the caisson to drop through the jack.

d. Miscellaneous equipment.

(1) Shore connection span. Shore connection spans (Figure 11-2) are transported to the erection site by the barge units required for the pier or wharf. Each span is 79 feet long by 30 feet wide by 4 1/2 feet high. The span is of girder construction with four 4 1/4-foot girders supporting a 3/8-inch sheet steel deck. It is shipped split lengthwise into 15-foot sections.

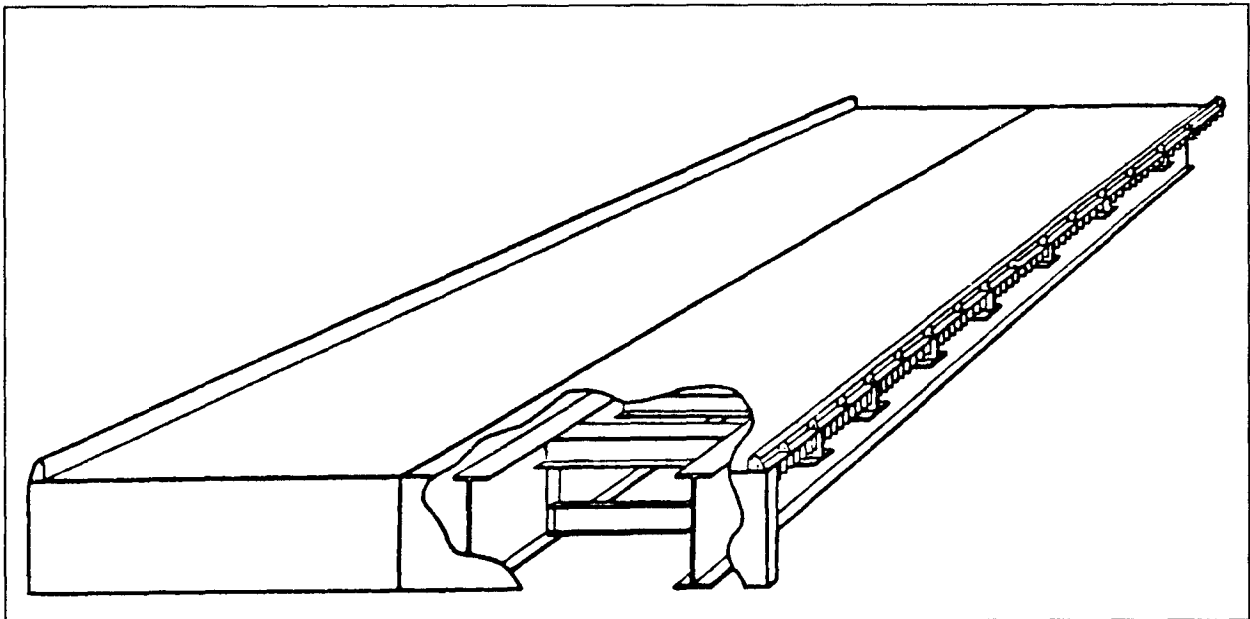

Figure 11-2. Shore Connection Span

(2) Compressors. Two 350-pound per square inch (psi), 400 cubic foot per minute (cfm) air compressors supply sufficient air pressure to operate and control the pneumatic jacks. The compressors should be secured as shown in Figure 11-3. They should be connected by flexible hose to a receiver tank inlet.

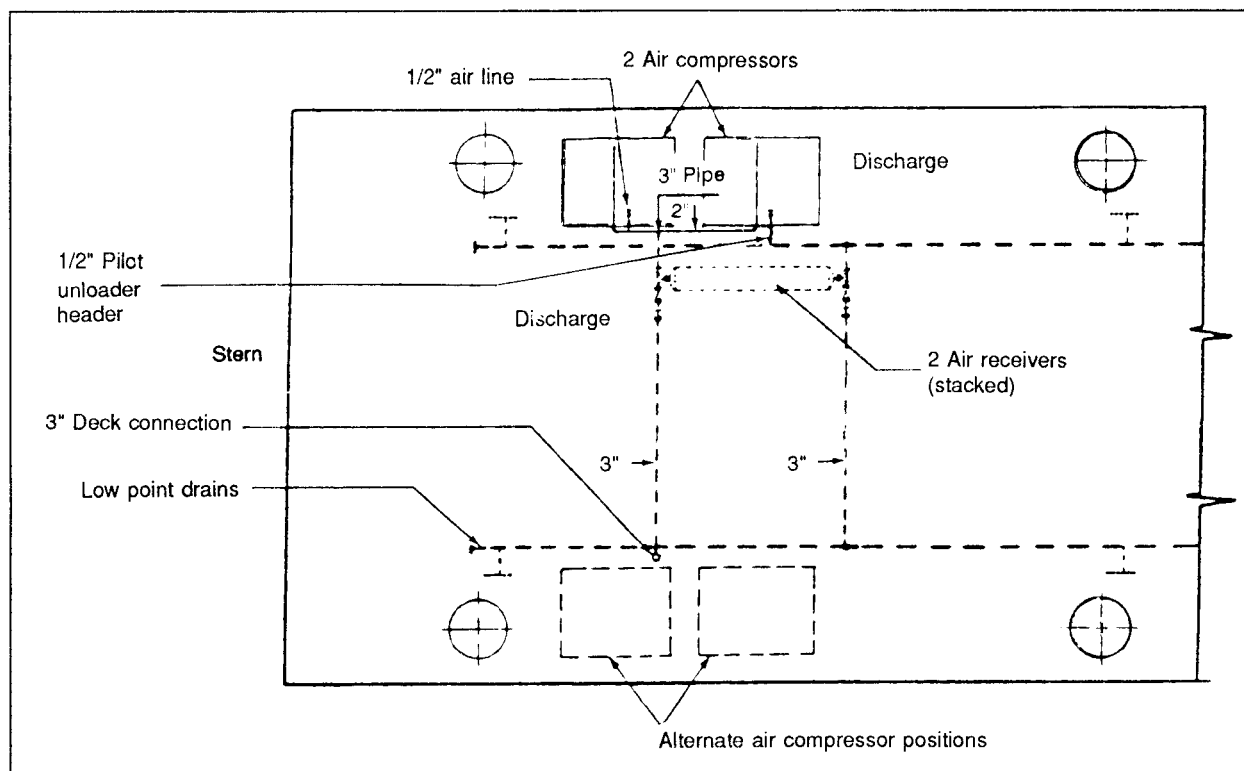

Figure 11-3. Compressor Positions

(3) Weld-off rings. Weld-off rings are pieces of steel tubing with a 10 3/4-inch outside diameter, a 1-inch wall thickness, and a 3-inch length. Eight weld-off rings per caisson are provided for semipermanent installations.

(4) Caisson covers. One steel caisson cover protects the cutoff caisson in a semipermanent installation and provides for each caisson-well in the barge unit.

(5) Fenders. The fenders for the "A" and "B" barges are made of 12 by 12 inch timbers and of 6 foot diameter steel hoops. One is provided per caisson.

e. Accessory equipment. Several items of useful equipment not provided with the barge unit include--

(1) Lifting cranes. The cranes listed below are necessary for erecting self-elevating DeLong barges.

(a) The self-elevating barge may be erected with one large barge-mounted crane. The crane should have a boom at least 200 feet long and a 75 percent tipping load rating exceeding 80 tons. The crane should also be capable of handling a boatswain's chair during lift. In addition, a smaller, at least 40-ton, barge-mounted crane may be used to hasten elevation.

(b) The above crane is not a military adopted item of material. Therefore, it may not be available at the site during construction. In this case, it becomes necessary to use at least two smaller barge-mounted cranes. They should each have a 100-ton capacity and 80-foot booms. Such cranes are available for issue from the Naval Ship Systems Command.

(c) Crawler-mounted cranes are useful in small lifting tasks, such as installing fenders and moving compressors and welding machines.

(2) **Welding apparatus.** If a large barge-mounted crane is not available, or a semipermanent installation is desired, welding equipment is necessary. Both oxyacetylene and electric-arc welding can be used in barge erection.

(a) Oxyacetylene welding equipment may be used. Only fusion welding with a low-carbon or high-strength steel rod is acceptable. A 300° Fahrenheit (F) to 500° F preheat is required with oxyacetylene apparatus.

(b) Electric-arc welding is preferable. It must be metal arc, using reverse polarity and 25-20 or modified 18-8 stainless steel shielded arc rods. No preheat is necessary.

(3) **Pile hammer specifications.**

(a) Able to work without shore connection.

(b) Six-foot diameter pile capacity.

(c) Rated striking energy of 120,000 foot-pound.

(d) Capable of sixty blows per minute.

(4) **Other floating equipment.**

(a) A 600-horsepower, 65-foot harbor tug must tow and position the self-elevating barge, especially if crossing open sea. In calm water, a 200-horsepower, 45-foot tug will suffice.

(b) An LCM is useful in positioning and hauling personnel and material between barge and shore.

(c) Various expedient floats, such as small rafts made from 55-gallon drums and small outboard motors, help speed elevation. They help particularly after the barge is jacked clear of the water.

SITE SELECTION FOR DELONG BARGE UNITS

a. **Tides.** Pier or wharf decks are usually positioned about 5 to 6 feet above mean high water. The mean tide range is the difference in height between mean high and mean low water. It is very important in selecting sites for piers or wharves.

b. Soil (foundation) conditions. Table 11-1 contains guidance in planning and site selection. If the erection site is in CONUS, data on offshore subsurface soil conditions is available through the US Geological Survey or from the appropriate Corps of Engineers district office. Outside CONUS, data, on subsurface soil conditions may be obtained from local sources, the theater army engineer; or military hydrology and hydrographic teams. All data should be checked by the engineer unit commander.

TABLE 11-1. Suitable and Non-suitable Soils for Erecting DeLong Barges

Types	Group Symbols	Suitability
Impenetrable surfaces	----	Unacceptable
Organic soils	Pt, OH, OL	Unacceptable
Fine-grained clays and silts, wet (mud)	MH, CH	Unacceptable
Fine-grained clays and silts, partly consolidated	ML, NH, CL-CH, CL-CM	Marginal
Fine-grained clays and silts, dry	ML, CL	Acceptable
Sand or sand with silt and clay	SW, SP, SM, SC	Acceptable
Gravel or gravel with silt and clay	GW, GP, GM, GC	Excellent

NOTE: Table based on weight of barge loaded to capacity

c. Wave action. Waves under 3 feet high cause little problem when dropping the caissons. Waves from 3 to 5 feet high require care to ensure that the barge stays in position. Waves over 5 feet high require extreme caution to ensure that the barge remains in place with equipment stowed securely. More time is needed to erect these barges in bad weather.

d. Shore accessibility. Ships must be able to dock under all tide conditions. Shore accessibility comes first in site selection. The depth of water at low tide must be at least 50 feet at the construction site. A distance of up to 1,000 feet between the shore and the end of the wharf or pier is desirable. Local bathymetry may help shorten selection time.

e. Approaches. Site selection should also consider onshore road networks. Construction of a new approach from the road net to the shore connection is expensive. However, the approach and the road net should have the following characteristics:

- * Straight for at least 150 feet back from the shore connection to avoid vehicles turning onto the connection.
- * Less than 10 percent grade at the shore connection.
- * At least two lanes (23-foot) travel width (41-foot clearance width), regardless of the connection width.
- * Constructed to withstand deterioration in wet weather.

f. Barge arrangements. There are many practical combinations of barges. Figures 11-4 and 11-5 illustrate some of the most promising arrangements.

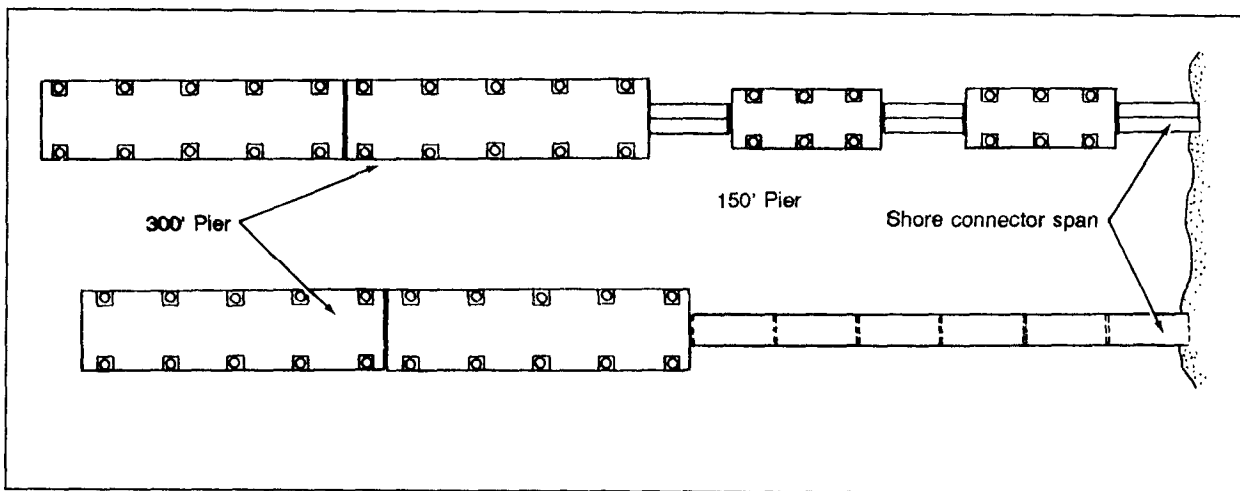

Figure 11-4. Finger Piers

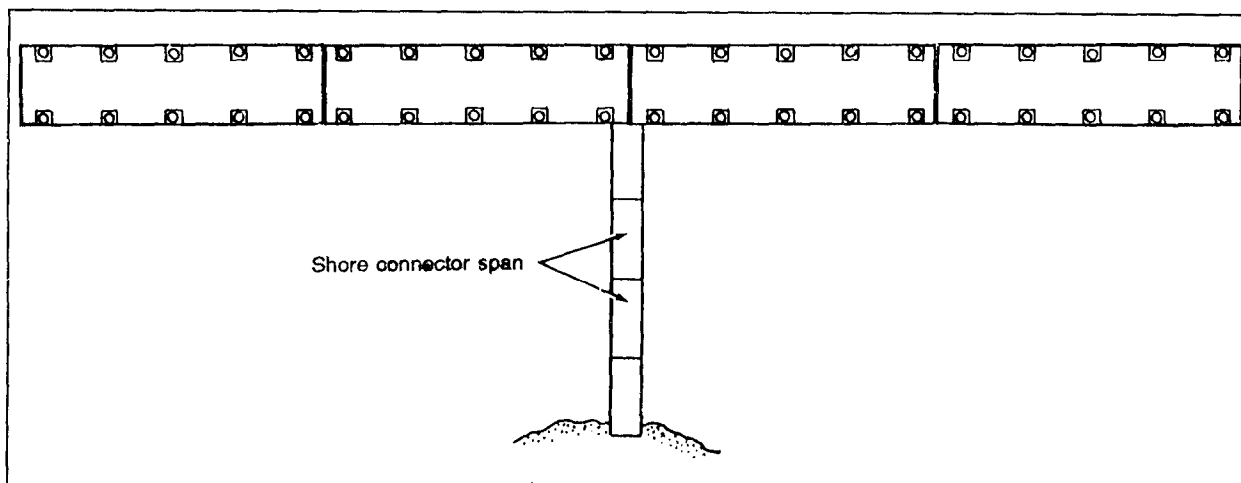

Figure 11-5. T-Type Marginal Wharf

PAST USES OF DELONG BARGES IN MILITARY CARGO HANDLING

a. Platforms for floating cranes. A large off-load crane mounted on a floating DeLong barge is one of the best methods for offloading container ships under an open sea of 5- to 6-foot waves and 28-knot winds.

b. Construction of general and/or break-bulk cargo piers. The live-load design of DeLong barges allows them to be used as general and/or break-bulk cargo piers. Barges are jacked to the desired elevation. Grippers within the jacks are inflated to 350 psi. The shutoff locks and isolation valves are closed.

c. Construction of container ports. Modified DeLong barges were used as a military container-handling facility in Camh Ranh Bay, Vietnam. The individual barges of this facility accepted the wheel loads of the container gantry crane. This type gantry crane weighs approximately 1,000,000 pounds and has design wheel loads of about 100,000 pounds on 5-foot centers. The gantry at Camh Ranh Bay had a lifting capacity of 27.5 tons.

LIMITS OF DELONG BARGE PIERS IN CONTAINER-PORT CONSTRUCTION

- a. **Erection time.** Each DeLong barge requires from 24 hours to 8 days for installation, depending on terrain and crew efficiency.
- b. **Structural integrity.** DeLong barge pier design takes a 500- to 600-pound per square foot live load. Modern military container ports need a minimum 1,000-pound per square foot live load. Unmodified DeLong barge piers cannot meet modern container port structural requirements.
- c. **Container-handling capability.** If modified DeLong barges are used to construct a temporary installation, cranes must boom up and down to keep from striking individual caissons. The top of the caissons severely affects the off-loading performance of most container-handling cranes. The barge is also jacked to the desired elevation. Grippers within jacks are inflated to 350 psi. Shut-off locks and isolation valves are closed.
- d. **Relocation.** Temporary installations made with DeLong barges are not easily moved. Semipermanent installations are much more difficult because caissons are driven to refusal, cut off, and then welded to the larger gantries. Seldom is it feasible to relocate them.
- e. **Foundation limitations.** Suitable foundations are limited to consolidated clays and nonplastic materials.
- f. **Shore-connection spans.** Shore-connection spans provided with DeLong barge piers do not possess the structural integrity for handling containers.
- g. **Fender systems.** Historically, fender systems provided with DeLong barges have not operated as desired. Damage has occurred to both vessel and pier. Expedient systems using old tires have been more successful in limiting damages.

Section II. Fenders for Barge Units

PURPOSE OF FENDERING

A fender system protects both the vessel and the docking facility from damage caused by contact between the two during docking. Berthing forces are critical because the loading centers on a small part of the facility. However, situations may occur when a ship is retained at a pier under environmental conditions too dangerous to risk berthing. A ship approaching from an angle of 10 degrees may come in contact with as little as 10 to 30 linear feet of the fender. After mooring, the same ship will normally have about one-half its length resting against the fender.

FENDER DESIGN

- a. Fender design for marine structures requires working technical knowledge of the--
 - (1) Size and berthing velocities of ships.

- (2) Magnitudes of surge and wave action.
 - (3) Hull configurations of ships and other vessels using the facility.
 - (4) Allowable force and deflection of pier or wharf structure.
 - (5) Soil conditions.
 - (6) Velocity and direction of winds.
 - (7) Tidal variation.
 - (8) Velocity and direction of currents.
 - (9) Availability and cost of materials, skilled labor, and equipment.
 - (10) Skill and experience of pilots.
 - (11) Approach difficulty.
 - (12) Availability of tugs.
 - (13) Amount of list that will occur in vessels, especially floating cranes and derricks.
 - (14) Willingness of operating personnel to maintain mooring lines.
 - (15) Presence and activity of marine borers and other causes of gradual deterioration.
 - (16) Facility design and lift.
- b. This large number of factors means that a single standard design for all sites is not appropriate.

FORCES FROM WINDS AND CURRENTS

Table 11-2, page 11-12, shows some of the forces from winds and currents acting on ships. This table shows the importance of mooring a ship parallel to strong currents. Wind and current forces are normally static. But when they combine with surge forces, they can impose large roll and surge movements on a vessel. In this situation, a highly resilient fender system may tend to amplify movement of the vessel. Large movements can quickly damage the pier, ship, and fender. Engineers should change the natural frequency of the ship and its mooring system so that it is out of phase with the combined waves and surge. Some remedial steps are:

- a. Hold the ship against the pier with a tugboat or constant-tension winch.
- b. Relocate or reorient the facility.
- c. Install mooring buoys or dolphins outboard of the pier face.

- d. Move bow and stern anchors to the outboard sides of the ship during berthing maneuvers.
- e. Change to more or less elastic bow, stern, and breasting lines or install elastic snubbers or dampeners in the mooring lines.
- f. Add or remove fender units.
- g. Place mooring dolphins inboard of the pier face if there is significant pier movement.

RECOMMENDED TECHNIQUES FOR FENDER DESIGN

Fender system designs must conserve energy. The port construction engineer must determine the amount of energy added to the system. Then he must devise a means to absorb the energy within the force and stress limitations of the ship's hull, fender, and pier. One method for devising a fender system to absorb this energy includes--

- a. Determining the energy delivered to the pier upon initial impact (Table 11-3, page 11-13). The selection of a design vessel should be based on recommendations from the Military Traffic Management and Terminal Service and the Military Sealift Command.
- b. Determining the energy that can be absorbed by the pier or wharf and consider distribution of loading. For structures that are linearly elastic, the energy is one-half of the maximum static-load level times the amount of deflection. Allowance must also be made for other vessels moored at the pier. A rigid structure can absorb no energy.
- c. Subtracting the energy that the pier will absorb from the effective impact energy of the ship to determine the energy the fender must absorb.
- d. Selecting a fender design that can absorb the energy determined above without exceeding the maximum allowable force on the pier. Consider that the thickness of the fender will affect the lifting capacity of the ship's gear and dock cranes.

Section III. Shore Connections

Self-elevating, spud-barge, pier units are usually erected as finger piers and, to a lesser degree, as marginal wharves. Since each must be in water deep enough to accommodate modern shipping, they require shore correctors. The following equipment may satisfy these requirements:

- a. DeLong Barge Wharf or Pier. One or more of the DeLong "B" units (150 by 60 by 10 feet) may connect the "A units (300 by 80 by 13 feet) to shore. This method jacks the connecting units to the same elevation as the wharf or pier (5 to 6 feet above mean high water). They would be less susceptible to weather than most floating connections.

b. **Military bridging.** Several military floating bridge units, including amphibious river crossing equipment, are described in Chapter 10. Because of its rapid installation (FM 5-210) and large loading capacities, this equipment can provide shore connections for most types of offshore ports.

c. **Navy pontoon gear.** Shore connections for many offshore wharves or piers may be provided with the P-series Navy pontoon gear outlined in Chapter 11.

d. **Other connections.** Pile-supported approaches or earth and rock fill causeways may be used when shore conditions, time, equipment, and material permit.

TABLE 11-3. Energy to be Absorbed by Fenders

Vessel	Length ft	Beam ft	Draft, ft		DWT (long tons x 1,000)	Velocity, ft/sec		Energy, ft-kips		Velocity, ft/sec	Energy, ft-kips	
			Light	Deep		Sheltered	Moderate	Sheltered	Moderate			Exposed
Assault Ships												
LHA	820	106	---	26.0	---	0.30	91.7	163.00	0.40	0.60	366.70	
LPD 4	570	84	17.0	22.0	7.0	0.30	40.3	111.96	0.50	0.70	219.50	
LPA 249	564	76	22.0	27.0	6.1	0.30	48.2	133.86	0.50	0.70	262.40	
LKA 113	575	82	15.1	25.5	14.0	0.30	31.0	104.10	0.55	0.80	220.30	
LSD 36	555	84	15.0	19.0	5.5	0.30	31.1	110.12	0.55	0.70	169.60	
LST 1179	518	68	11.5	15.0	3.5	0.35	25.5	74.88	0.60	0.90	168.50	
Roll-on/Roll-off												
Comet	500	78	25.0	29.0	6.5	0.30	49.9	138.73	0.50	0.70	271.90	
Sealift	540	83	19.5	29.0	12.1	0.30	57.2	158.80	0.50	0.70	311.20	
Admiral Callaghan	694	92	19.5	27.0	13.5	0.30	60.5	168.00	0.50	0.70	329.30	
General Cargo												
C-2	455	63	15.0	27.0	9.7	0.30	40.4	135.80	0.55	0.80	287.40	
C-3	492	70	16.0	29.0	12.7	0.30	52.1	144.69	0.50	0.70	283.60	
C-4	564	72	20.0	33.0	14.0	0.30	66.3	184.16	0.50	0.70	361.00	
Tankers												
T-2	524	68	14.0	30.0	16.5	0.30	64.5	179.23	0.50	0.70	351.30	
T-5	656	86	16.5	35.0	23.6	0.30	99.7	224.22	0.45	0.60	398.60	
MSTS	595	84	14.5	32.5	25.5	0.30	86.9	195.52	0.45	0.60	347.60	
AOR 2	659	96	21.0	35.0	25.0	0.30	86.6	194.87	0.45	0.60	346.40	
Universe Ireland	1135	175	26.0	79.0	326.5	0.20	497.5	1119.66	0.30	0.40	2984.70	
Barge Transports												
LASH	860	107	20.0	37.0	44.0	0.30	161.5	219.83	0.35	0.50	443.60	
Seabee	875	106	17.5	32.0	27.0	0.30	112.2	199.48	0.40	0.55	374.00	
Break-Bulk Freighter												
VC-2	455	62	15.5	29.0	10.6	0.30	46.1	127.91	0.50	0.80	327.40	
Mariner	563	76	18.0	30.0	12.9	0.30	59.4	164.94	0.50	0.70	323.30	
Gulf Banker	495	69	18.5	30.0	11.0	0.30	50.3	139.81	0.50	0.70	274.00	
Freighter/Container												
Seamaster	572	82	21.0	30.5	12.8	0.30	62.5	173.60	0.50	0.70	340.30	
Santa Lucia	560	81	20.0	30.0	12.7	0.30	59.1	164.23	0.50	0.70	321.90	
Wolverine Mariner	564	76	21.5	32.0	12.7	0.30	65.7	182.61	0.50	0.70	357.90	
Challenger	560	75	20.0	31.5	13.5	0.30	60.8	168.80	0.50	0.70	330.80	
Container with Crane												
Pacific Trader	544	70	21.0	32.0	12.2	0.30	68.1	190.59	0.50	0.70	373.60	
American Liberty	700	90	21.0	32.0	19.0	0.30	87.3	196.45	0.45	0.65	409.87	
Container without Crane												
Portland	523	72	22.0	31.0	9.7	0.30	58.6	162.64	0.50	0.70	318.80	
Oakland	685	78	19.0	30.0	17.0	0.30	89.9	200.00	0.45	0.65	414.80	
Jacksonville	524	68	19.5	31.0	11.6	0.30	68.5	190.34	0.50	0.70	373.10	

NOTE: Table data obtained from WES Technical Report H-73-9.

CHAPTER 12

EXPEDIENT CONSTRUCTION

GENERAL

a. Standard port designs allow delivery of cargo. Nonstandard expedient construction port designs must serve as substitutes when engineers lack time or resources to construct or rehabilitate standard ports. The engineer has only his ingenuity. This chapter does not focus on prescribed construction methods. It provides engineers with expedient replacement or repair concepts.

b. The modern container port may need expedient construction repairs. Lack of port expertise and marine construction equipment will complicate this problem. Rehabilitation of damaged ports to their original condition would be impossible. The alternative is to develop repairs which can be completed in the shortest possible time, while minimizing requirements for sealift shipping and worktime. Many of the concepts discussed in this chapter have not been tried or proven in either commercial or military container ports. Most details discussed in this chapter are shown graphically in Appendix A.

EXPEDIENT CONSTRUCTION EQUIPMENT

Expedient construction equipment consists of the following:

a. Launchers or tugboats with shorelines to haul and hoist loads during waterfront construction.

b. Floating cranes made by erecting a derrick or installing a crawler- or truck-mounted crane on a regular barge, LCM, pontoon cubes, or a barge fabricated from military floating bridge units.

c. Rafts for pile-bent bracing may be built on the job, using oil drums, heavy timbers, spare piles, or local material.

d. Floating dry docks for small craft made from Navy pontoons.

e. Light barges, floating wharf approaches, and small floating wharves made from steel oil drums.

EXPEDIENT PIERS OR CAUSEWAYS

Expedient piers or causeways include the following:

a. DeLong piers provide quick and lasting off-load capability.

b. Marathon-LeTourneau barge piers erected quickly (50 feet per hour) reproduce or upgrade existing pier facilities.

- c. Bailey bridges and standard military float bridging make expedient causeways or pier supports.
- d. Navy P-series pontoons offer excellent light cargo off-load capability.
- e. Hulls of capsized or sunken vessels can provide substructures for piers or causeways.

EXPEDIENT REPAIR CONCEPTS FOR PILE FOUNDATIONS

An expedient foundation is a fabricated base, transferring loads from the pile to the ocean floor. This base distributes pile loads over a large area. The bearing capacity of the soil supports the load. A worst-case soil bearing capacity is 2,000 lb/sq.ft. Expedient pile foundations serve where no previous pile existed, or where the existing foundation cannot be used because of damage. The entire foundation can be assembled before lowering it to the ocean floor. This speeds the repair process and cuts diver time underwater.

a. Steel beam foundation.

(1) Concept: Steel wide-flange beams used to form an expedient foundation for pile repair (Figure 12-1).

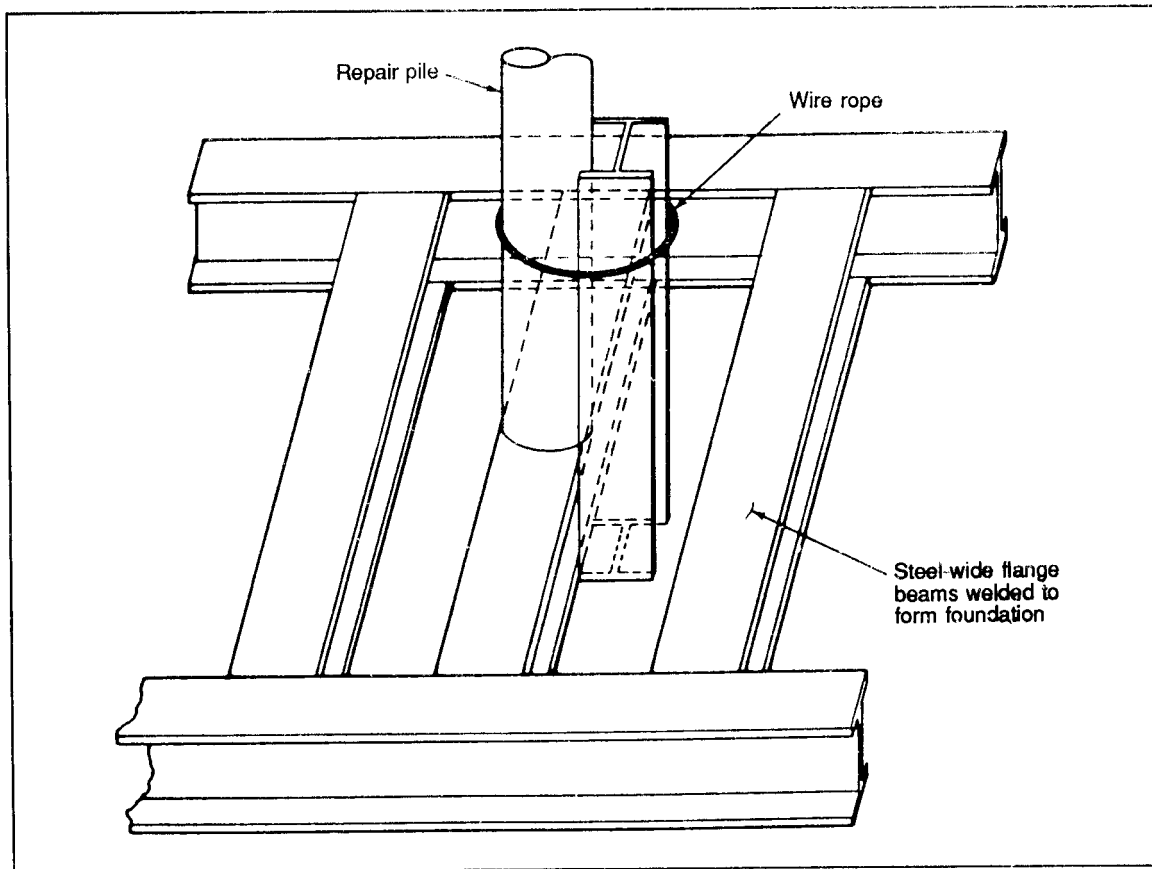

Figure 12-1. Steel Beam Foundation

(2) Description: Pile placement may be required where a site has no pile or where a driven pile is damaged and cannot serve as a foundation. Here, expedient foundations can be built from steel wide-flange beams that distribute the pile loads to the ocean floor. The beams are welded together, and the repair column is placed on top. A worst-case soil bearing value of 2,000 lb/sq.ft. is assumed. This value and the pile loading determine the total area of steel beams required in contact with the ocean floor. Placement of this foundation requires a level area clear of debris. This requirement and the likely settling of the foundation mean one should use this method only if the base of the existing pile cannot serve as a foundation.

b. Concrete foundation.

(1) Concept: 55-gallon steel drums used as concrete forms to build an expedient foundation for pile repair (Figure 12-2).

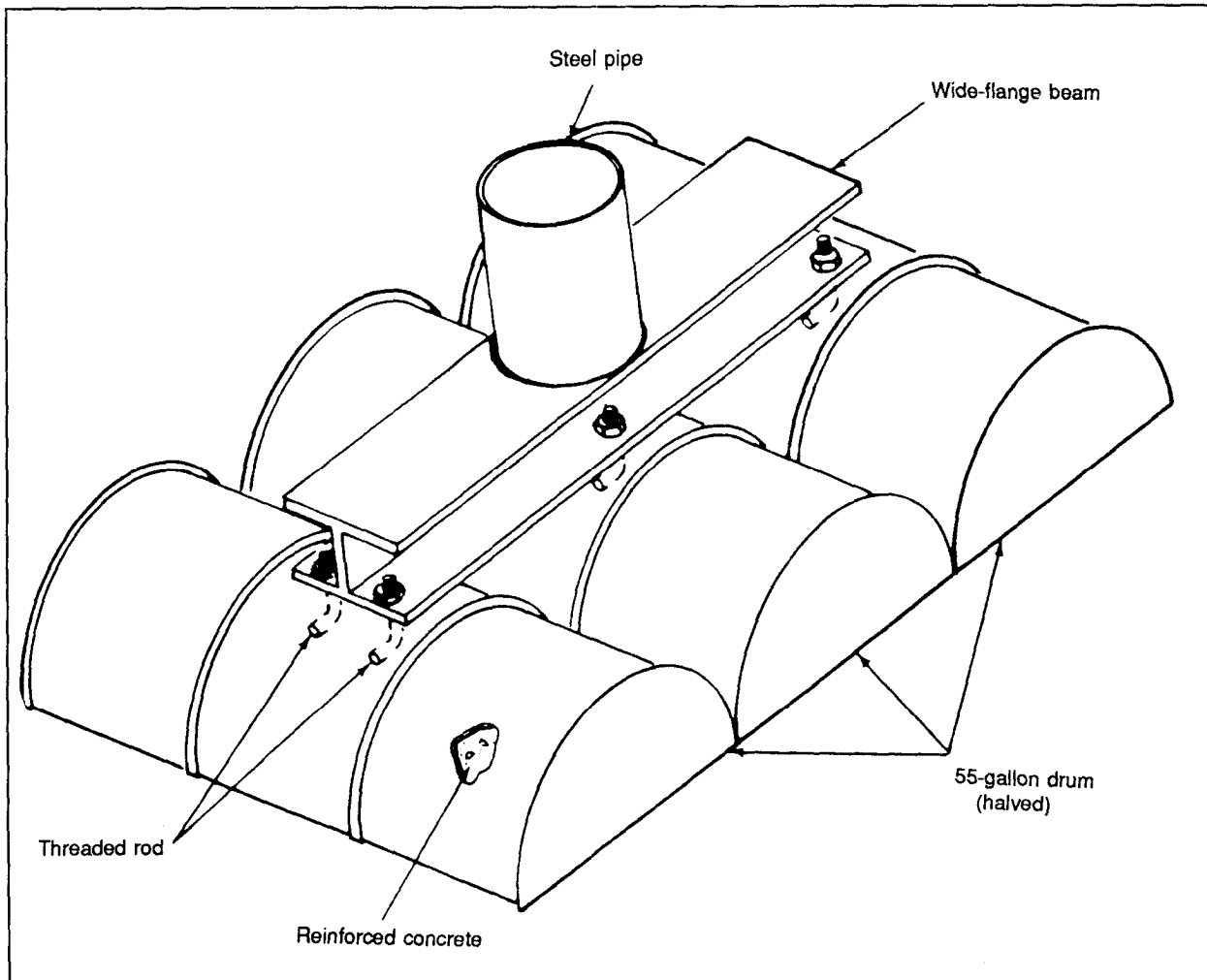

Figure 12-2. Concrete Foundation

(2) Description: This technique is used if the base of the pile being repaired cannot serve as a foundation or when the foundation is new. The 55-gallon steel drums are halved lengthwise and filled with reinforced concrete. A threaded rod is embedded in the concrete of each foundation member to attach the individual forms together. A steel wide-flange beam is attached to the threaded rods. This beam distributes the load, evenly, to each of the individual foundation members.

c. Container-floor or steel-plate foundation.

(1) Concept: A flat steel plate or the floor of an ISO container used as a foundation for a pile repair (Figure 12-3).

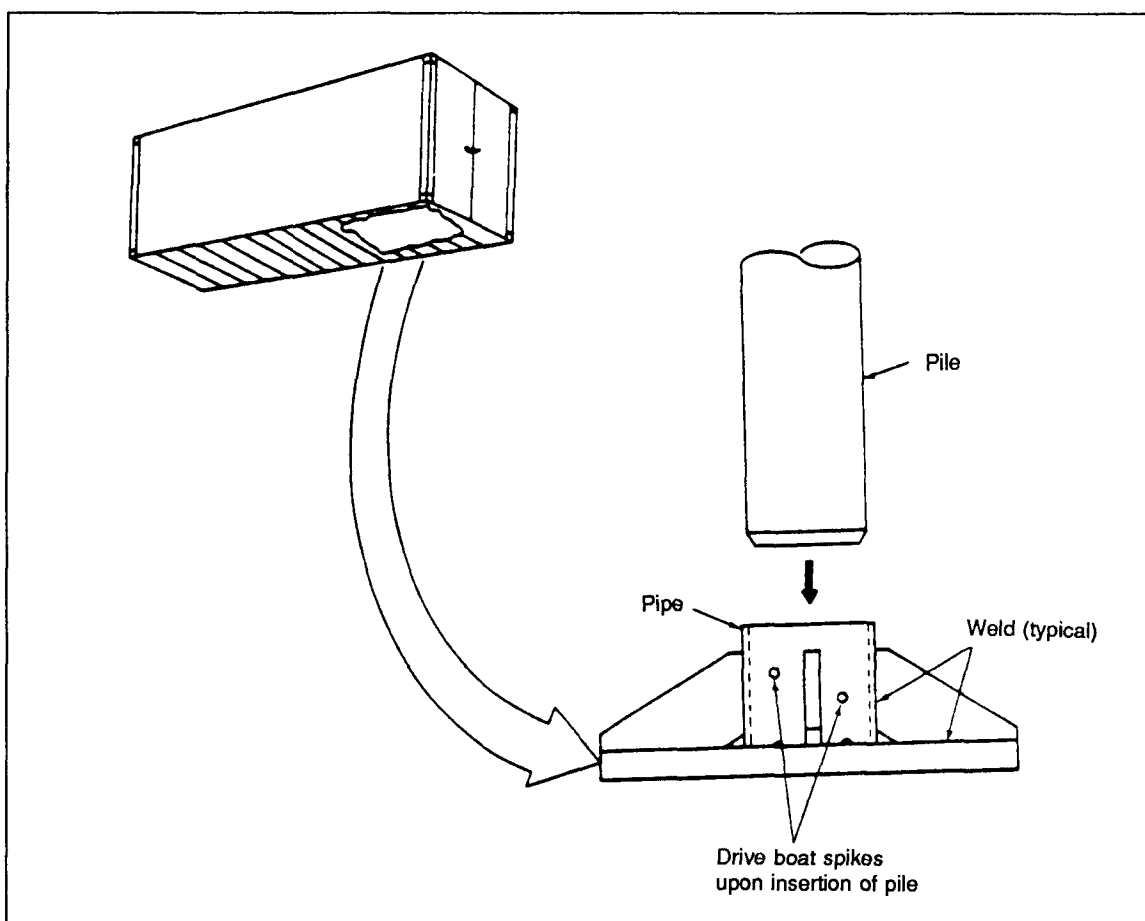

Figure 12-3. Container-Floor or Steel-Plate Foundation

(2) Description: An expedient pile foundation can be made using steel plate or a portion of an ISO container floor. This foundation permits the transfer of the pile loads to the ocean floor. A steel pipe is attached to the center of the foundation. Gussets, to resist bending, run from this pipe to the outer edges of the plate. This foundation requires a large level area at the point of application, and should be used when the base of the pile cannot be used or is not there.

d. Rubble foundation.

(1) Concept: Rubble and high-early-strength concrete used to provide a pier pile foundation (Figure A-1).

(2) Description: An expedient pile foundation can be formed using steel scraps, concrete debris, and large rocks. The sea floor is excavated at the foundation site. The rubble is placed in the resulting cavity, partially filling it. The repair column is placed on top of the rubble and braced in position. The hole is then filled with additional rubble, and high-early-strength concrete is pumped into the rubble to consolidate the foundation. This expedient foundation distributes the load from the pile to the ocean floor.

REPAIR CONCEPTS FOR PILE-SUPPORT STRUCTURES

a. The decision on whether to repair or replace is made on a case-by-case basis. Several questions must be answered before deciding to repair or replace:

(1) Is the pile repairable? (For example, is it split lengthwise, has it been extensively damaged by marine borers, is it severely splintered?)

(2) Are repair materials available?

(3) Is the pile stub accessible, and can it be removed with the equipment available?

(4) Is a pile driver operator available to drive the replacement pile?

(5) Will the proposed repair withstand the anticipated load?

(6) Do operational requirements allow the time needed for pile replacement?

b. The following section describes repair concepts that supply strength equal to the original undamaged pilings. Figure A-2 identifies structural elements of a pier or wharf with a damaged pile. Figure A-3 presents several cross-sectional pile shapes and the corresponding area formulas used for calculations. Table 8-1, page 8-10, assumes the maximum load per pile to be the actual loading for each size and type of pile listed. Equating like loads can determine equivalent pile sizes, or diameters for steel, wood, or concrete piles (Figures A-4 and A-5). All pile replacement concepts use this method of equivalency to determine the minimum-sized column required. Using this method, designers do not need to know deck-load capacities to repair the support structure.

(1) Wood columns.

(a) Concept: A single wood column used to replace an existing wood, concrete, or steel pile on a foundation (Figure A-6).

(b) Description: This repair uses, as a foundation, the undamaged portion of the existing disabled pile embedded in the ocean floor. In this way, the frictional resistance developed from driving the original pile can still transfer the vertical loading of the column to the ocean floor. A wood column placed on top of this foundation is used to bridge the distance to the pile cap. Marine borer or mechanical damage can make this portion of the pile useless as a foundation. An expedient foundation can be built using concepts in Chapter 4. The bracing pattern shown in Figure A-6 is typical. It resists lateral loads from mooring, wind, current, and wave forces.

(2) Bundled wood columns.

(a) Concept: A bundle of wood columns to replace an existing wood, concrete, or steel pile on a foundation (Figure A-7).

(b) Description: As examined in the single wood column concept, this repair uses the undamaged portion of the existing disabled pile as a foundation. If material for a single column replacement is not available, several smaller-diameter wood columns may be used. These columns will be bundled together in groups of two, three, or four members. Steel band strapping, spaced every foot of column length, is used to hold the separate members together. The bundled column then bridges the gap between the foundation and the pile cap. Bracing is required. A steel bearing plate is also required to transfer the load from the pile cap to the column, and from the column to the foundation.

(3) Steel columns.

(a) Concept: A steel column used to replace an existing wood, concrete, or steel pipe on a foundation (Figure A-8).

(b) Description: This concept also uses the bearing capacity of the base of the damaged pile. It uses a steel column of sufficient strength to transfer the deck loading to this foundation. The strength of the steel column member depends upon its cross-sectional area and shape. The shape determines the member's ability to resist buckling for a given column length. Bracing is required to resist lateral forces.

(4) Welded steel rail columns.

(a) Concept: A steel rail used to form a column and replace a damaged wood pile, concrete, or steel pile on a foundation (Figure A-9).

(b) Description: Three sections of steel rail can be welded together to form a column. This column has improved strength characteristics resulting from its configuration. The column runs between the pile cap and the undamaged portion of the original pile. The common 115 pounds per yard rail, serves for column lengths of 37.7 feet or less. Bracing is required to resist lateral forces.

(5) Reinforced concrete pile repairs.

(a) Concept: Reinforced concrete is used to repair a damaged section of a wood, concrete, or steel pile (Figure A-10).

(b) Description: This method repairs a damaged pile that is still intact from the sea floor to the pile cap. This method repairs split or broken timber piles, cracked or chipped concrete piles, or mechanically damaged steel piles. Steel reinforcement is placed around the repair area, and a form is placed to contain the concrete. If "Sea Form" fabric forms are not available, culvert pipe, oil drums, or corrugated roofing can make expedient forms. The damaged part of the pile is then encased in concrete for alternate forms (Figure A-11).

(6) Container used as a pile replacement.

(a) Concept: Stacked ISO containers used to replace a pier pile (Figure 12-4).

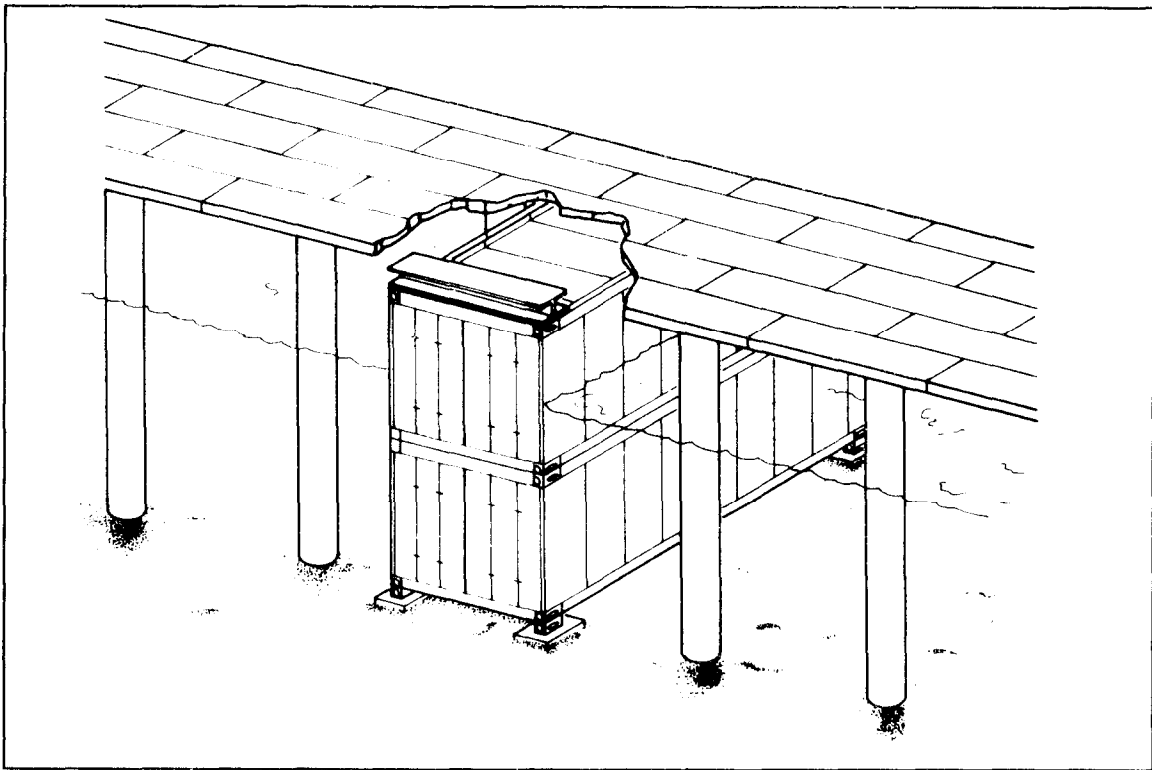

Figure 12-4. Container Used as Pile Replacement (Support Structure)

(b) Description: This repair uses the corners of an ISO container as a column. If the repair requires a column of greater length, up to five containers can be stacked. Only the corners of these containers can support a substantial load. A beam is used to span the distance from corner to corner.

c. The corners must be placed on individual foundations to minimize the are of ocean floor to be cleared of debris. These foundations must have a total area equal to the minimum foundation area, as required in Chapter 4. The containers must be made level for proper load distribution by shimming the foundation footings. Lightening holes in the sides, tops, and bottoms of the containers lessen the effect of water forces (current or wave) acting on these surfaces.

TRUSSES

a. Timber truss.

(1) Concept: A timber truss used to replace a damaged pile using two neighboring undamaged piles (Figure A-12).

(2) Description: The truss members run from the pile cap to adjoining undamaged piles. The truss repair is actually two trusses, which are attached on both sides of the adjoining piles to transfer the load. These neighbor piles support a greater load. The rating of the affected area of the pier must be lowered to two-thirds of its initial load capacity. The truss members are sized to meet tension and compression forces, and to resist buckling. This method can replace timber or steel pipe piles. Figure A-13 shows the connection of a truss to the pile cap, and Figure A-14 shows the connection of the truss to the pile.

b. Steel truss.

(1) Concept: A steel truss used to replace a damaged pile using two neighboring undamaged piles (Figure A-15).

(2) Description: Same as for a timber truss connection to the pile (Figure A-16) and a connection to the pile cap (Figure A-17).

BRACING AND CONNECTING METHODS

Bracing in the repair area resists lateral loads from mooring, wind, current, and wave forces (Figures A-18 through A-21). Transverse bracing is typically 4 by 8- or 4 by 10-inch timbers. Bracing is applied diagonally and attached to each pile with a single 3/4-inch bolt. Transverse bracing has a vertical spread from the low water line to the lower edge of the cap.

Figures A-22 through A-28 show suggested connecting methods. The final connection depends on the logistics of the particular repair and on the replacement pile and connecting material available. Figures A-22 to A-25 show connecting methods which serve as column to base or cap connections, and Figures A-26 through A-28 present ideas for column to base connections.

a. Bracing Method 1.

(1) Requirements:

- (a) Connection area must be free of loose debris.
- (b) One bolt is used per connection.
- (c) Galvanized steel fasteners are preferred, but threaded rods may be used.

(2) Procedure:

- (a) If using a timber pile, drill through the diameter of the pile.
- (b) If using a steel pipe pile, drill or torch a hole through the diameter of the pile.

(c) Attach the brace to the pile with a bolt, nut, and washers.

b. Bracing Method 2.

(1) Requirements:

(a) Connection area must be free of loose debris.

(b) One bolt is used per connection.

(c) Galvanized steel fasteners are preferred, but threaded rods may be used.

(2) Procedure:

(a) Drill or torch a hole through the beam flange.

(b) Attach the brace to the pile with a bolt, nut, and washers.

c. Bracing Method 3.

(1) Requirements:

(a) Connection area must be free of loose debris.

(b) One brace bracket is used per connection.

(c) Galvanized steel fasteners are preferred, but threaded rods may be used.

(2) Procedure:

(a) Drill two holes in each steel flatbar, 1 1/4 inch from each end.

(b) Attach the brace to the pile using the brace bracket, bolts, nuts, and washers.

d. Bracing Method 4.

(1) Requirements:

(a) Connection area must be free of loose debris.

(b) One concrete anchor is used per connection.

(c) Bracing Method 3 is the preferred method of connecting a brace to concrete.

(2) Procedure:

(a) Drill a hole in the concrete pile.

(b) Attach the brace to the pile with the concrete anchor using a flat washer.

e. Connecting Method 1.

(1) Requirements:

(a) The diameters of both spliced connections must be the same.

(b) Bolts must fit snugly along the sides of the column and base.

(c) If either the column or base is a steel pipe, a 1/4-inch steel plate must be placed between the column and base or cap.

(d) Galvanized steel fasteners are preferred, but threaded rods may be used.

(2) Procedure:

(a) Drill holes in the steel plates to allow bolts along both sides of the base and the repair column.

(b) Place the repair column directly between the base and cap.

(c) Loosely connect the two plates by installing four bolts along only one side.

(d) Slip the plates over the area to be spliced, and insert the four remaining bolts through the plates.

(e) Tighten the bolts evenly and torque the nuts to 100 foot/pounds to complete the splice.

f. Connecting Method 2.

(1) Requirements:

(a) The diameters of both spliced connections must be the same.

(b) Steel channel or I-beam sections may be used as splicing members.

(c) If either the column or base is a steel pipe, a 1/4-inch steel plate must be placed between the column and base or cap.

(d) Galvanized steel fasteners are preferred, but threaded rods may be used.

(2) Procedure:

(a) Drill holes in the splice members and column through the center to accommodate the two 3/4-inch bolts. First, drill two holes through the column at least 6 inches from the column end and 6 inches apart then drill two holes in the splice members to match the column holes.

(b) Loosely bolt the splice members to the column.

(c) Position the column directly between the base and cap, with the splice members loosely over each side of the base and cap.

(d) Torque nuts to 100 foot/pounds to align the column, base, and cap and to complete the splice.

g. Connecting Method 3.

(1) Requirements:

(a) The diameters of both spliced connections must be the same.

(b) If either the column or base is a steel pipe, a 1/4-inch steel plate must be placed between the column and base or cap.

(c) Galvanized steel fasteners are preferred, but threaded rods may be used.

(2) Procedure:

(a) Drill clearance holes through the center of each 3/8- by 2-inch steel flatbar to accommodate the 3/4-inch bolts.

(b) Drill two holes through the column at least 3 inches from the column end and 3 inches apart.

(c) Place the 3/4-inch bolts loosely through the steel flatbar, the column, and the flatbar on the other side of the column.

(d) Install the steel angle sections lengthwise along the column between the flatbar and the column. Tighten the bolts to hold the angles in place.

(e) Weld flatbars to angles.

(f) Loosen bolts.

(g) Place the column directly between the base and cap, with the splicing members loosely over each side of the base foundation.

(h) Torque nuts to 100 foot/pounds to align column, base, and cap and to complete the splice.

h. Connecting Method 4.

(1) Requirements:

(a) Welded angles must fit snugly along the sides of the base foundation or pile cap.

(2) Procedure:

- (a) Drill clearance holes for two 3/4-inch diameter bolts through the shorter leg of one of the steel angles (#1), 3 inches from each end.
- (b) Lay the steel angle #1, holes down, on the steel plate, aligning the edges of the angle with the edge of the plate. Mark the location of the two bolt clearance holes.
- (c) Drill the two bolt clearance holes in the steel plate.
- (d) Drill and counter-bore holes in the steel plate for the drift pins.
- (e) Weld steel angle #1, without holes, to the steel plate.
- (f) Weld the second steel angle (#2) to the steel plate.
- (g) Center the plate on the end of the repair column and the drive drift pins through the plate into the column.
- (h) Position the repair column directly between the base pile and cap.
- (i) Bolt the remaining steel angle (#1) to the bottom of the steel plate to complete the splice.

i. Connecting Method 5.

(1) Requirements:

(a) Must be able to closely align the repair column to the base foundation to match bolt holes and install bolts.

(b) Preferably all fasteners are galvanized steel.

(2) Procedure:

(a) Drill four 1-inch diameter holes in the corners of the top steel plate, 1 1/2 inches in and 1 1/2 inches down from each corner.

(b) Drill four 1-inch diameter holes in the corners of the bottom steel plate to match the holes in the top plate.

(c) Center and weld the steel pipe sleeve to the bottom plate.

(d) Center and weld the steel pipe column to the top plate.

(e) Center the bottom plate over the base pile.

(f) Place the column directly between the base and cap, align bolt holes, and install the four 3/4-inch bolts and nuts.

(g) Torque the nuts to 100 ft-lb to complete the splice.

i. Connecting Method 6.

(1) Requirements:

(a) Make splice below the ocean floor.

(b) If either the column or base is a steel pipe or the repair column diameter is greater than the base pile diameter, a 1/4-inch steel plate must be placed between the column and base.

(2) Procedure:

(a) Place the repair column through the culvert pipe.

(b) Place and hold the repair column directly over the base pile.

(c) Lower the culvert pipe over the splice area and bury the bottom 2 inches into the ocean floor.

(d) Hold the repair column in place by inserting four metal wedges between the culvert pipe and the column.

(e) Pump concrete into the space between the culvert pipe and the pile to complete the splice.

k. Connecting Method 7.

(1) Requirements:

(a) Make splice below the ocean floor.

(b) If either the column or base is a steel pipe or the repair column diameter is greater than the base pile diameter, a 1/4-inch steel plate must be placed between the column and base.

(2) Procedure:

(a) Position the repair column directly above the base foundation and hold it in position.

(b) Concentrically locate the sheet metal form around the repair column and base, and bury the bottom two inches into the ocean floor.

(c) Place band clamps around the sheet metal form.

(d) Hold the repair column in place by inserting four metal wedges between the metal form and the column.

(e) Pump concrete into the space between form and piles to complete the splice.

EXPEDIENT REPAIR CONCEPTS FOR PIER AND WHARF DECKING

a. **Steel Plate Concept.** Steel plates can quickly cover the damaged area of a pier. A 2-inch steel plate with a yield strength of 60 kips per square inch can bridge a gap of 8 feet for a Caterpillar (Cat) 988 Forklift with a fully loaded container. An 8-foot wide plate can resist the load. No edge support is provided in repairing a rectangular gap (see Figure A-29). If the crater is round and 8 feet in diameter, the plate requires some side support and only one wheel could be in the center of the hole. The other must be on the undamaged surface of the pier. It might be possible to support one wheel of a fully loaded Cat 988 in the middle of an 8.4-foot crater with a 1-inch, 60-kips per square inch (ksi) steel plate. The raised edge of the plate will not cause operational problems for container handling vehicles.

(1) An 8-foot width of plate may resist the load of a container-handling vehicle. Sometimes the loads will be carried by two separate plates (see Figure A-29) with lower material stresses. Loads may also be carried by the edge of the plates, but with higher material stresses. The 8-foot effective width is used for preliminary sizing during the design phase.

(2) Plate repairs are attractive because of their simplicity and easy installation. Ten 1,000-pound steel plates can be selected from a stack, loaded onto a truck, unloaded, and placed in 1.5 hours. An 8-foot by 10-foot, 2-inch steel plate weighing 6,400 pounds could be used to repair the 8.4-foot diameter craters specified in the original scenario. At least six such repairs could be made in a 9-hour day. Instead of cranes, a large vehicle could drag the plate to the installation site since friction is slight between steel and concrete. The plate may be secured against sliding at the repair site by anchoring it to the undamaged deck with anchor bolts. Attaching rods to the plate and allowing them to protrude down through the open area in the deck and bear against the edges of the crater will also prevent slippage. Holes in the plates should be provided on 12-inch centers for bolts, attachments, and handling aids.

(3) Steel plates will deflect before ultimate failure. Personnel observing the deflection are warned of impending overload. Small overloads will cause permanent distortion of the plate, but not complete collapse. Plates, bent by handling or overload, may be placed so that it arches up. They may, however, fail in fatigue after being bent several times. Two-inch thick, 60-ksi plates offer sufficient moment resistance to be useful. Little field modification is required to install plates, fabricating high-strength plates is not a problem. Two-inch thick, 60-ksi plates span gaps up to 8 feet for heavy container handling equipment, up to 18 feet for the 1,000 lb/ft² loading, and up to 23 feet for the HS 20-44 loading. Maximum deflections will be approximately 2, 10, and 13 inches respectively.

(4) Two-inch thick, 60-ksi plates are not available as a standard product. However, high-carbon proprietary steels are available in the 50- to 80-ksi range. ASTM A514 Quenched and Tempered 100-ksi steel is available as a standard product. The A514 can be welded with some difficulty and has reasonable toughness and ductility. An 8-foot effective width of plate which is 2-inch, 100-ksi steel plate will span a gap of 13 feet with a Cat 988 or 250-ton truck crane, 23 feet for a 1,000 lb/ft² load and in excess of 30 feet for the HS 20-44 load. Maximum deflections are 10, 27, and more than 30 inches respectively. A gap spanned by 100-ksi, 2-inch steel plate will be limited by deflection criteria rather than bending failure. If one steel plate does not offer sufficient resistance, another one may be stacked on top, doubling the resistance.

b. Erector-Set Concept. A larger moment-carrying capacity may be created by separating the tension and compression areas of a flexural member. Repair modules may be made with wide flange steel beams which are sandwiched by 1-inch steel plate (Figures A-30 and A-31). The assembly may be bolted together to develop the composite strength of the whole module (Figure A-32). The following parts are required:

(1) Top and bottom plates 8 by 40 feet, 1-inch thick with holes drilled on 4-inch centers for 1-inch bolts over the entire area. These will act as tension and compression flanges.

(2) Wide-flanged, rolled sections with corresponding holes in the flanges. These will provide shear resistance between the tension and compression flanges.

(3) Some type of transverse stiffening member is necessary to ensure that the entire section width acts together.

(4) One-inch diameter bolts.

(5) Special clips or cages which will hold the nuts in place while the bolts are being turned. The nuts may be inaccessible during certain stages of construction.

(6) Twenty 4-inch wide by 1/2-inch thick plates with a bolt hole pattern to match the other components. These will be used to splice the 1-inch plates.

(7) End ramps for nonflush repairs. These may be made from materials salvaged in the TO.

(8) Angle iron with matching hole patterns to create boxes.

(9) A shim package for matching the repair components to the existing structures. All components will be packed into containers or assembled into racks compatible with the containers.

(10) The repair components can be configured in several different ways:

(a) The modules may be laid on top the deck over the damaged area and ramps provided to accommodate vehicles (Figure A-33, Type A).

(b) The deck may be sawcut to accept the modules so their tops will be flush with the deck. The modules will be supported by bearings attached to the bottom of the deck or to the pile caps (Figure A-33, Type B).

(c) Steel beams may be attached to the plate so they protrude only through the damaged area. The repair will be supported where the plate overlaps the undamaged portion of the deck (Figures A-34 and A-35).

(d) A combination of steel beams and plates may be assembled to create an expedient pile cap. A steel beam will be clamped on either side of the undamaged portion of the pier cap. If extra strength is needed, a plate will be bolted on the top and bottom of the two beams. A shim package is necessary to provide proper spacing so the holes in the plates and the beams line up (Figures A-36 and A-37).

(e) Any of the previously mentioned repairs could be supported by piling. An appropriate attachment could be made to the bottom of the module to distribute the load.

(f) Placement of beam and plate elements could be optimized, so the repair provides the correct amount of moment, shear resistance, and transverse stiffness where it is needed most (Figure A-38).

(g) The steel beams could be used as piling, if necessary.

(h) Heavy angle plates assembled to form rubble boxes for gravity retaining walls could be used for expedient quay wall repair (Figure A-39).

(11) The advantages of the “erector set” concept involve versatility. The components may be assembled in any configuration with adjustments made for unforeseen circumstances. Engineer units will also find other uses for the components.

(12) The disadvantages to the “erector set” concept involve assembly problems. Bolting consumes most of the assembly time. Misalignment of bolt holes is an inevitable problem. However, steel erection crews have a variety of techniques and tools available to remedy misalignment problems. The use of a different fastening system, possibly copied from another expedient military device, might speed the assembly.

c. **Steel Beam Mat Concept.** A continuous mat of steel beams laid side by side may also be used as a bridge. The weight of a container-handling vehicle is shared by at least four beams because the wheels are wide enough to bear on at least two beams each (Figure A-40). The flanges of the beams will be about 1 foot wide. Scheduled time and workhours are one-third the “erector set” full rectangular repair module concept because the beams must only be bolted together enough to prevent lateral instability and shifting. One bolt per square foot is used to estimate manhours and schedule time. This concept is not as flexible as the “erector set” concept for forming alternative repair configurations.

d. **Steel Beam and Timber Deck Concept.** Timber or laminated wood could be used to provide a deck for an expedient repair. Wood may be the material of choice because of its availability within the TO. Army construction troops find this concept compatible with the construction methods and materials which they know best. This repair is constructed as follows:

(1) Remove unsound concrete and rebar from the edge of the crater.

(2) Drill bolt holes for the beam hangers through the deck with a pneumatic jackhammer or diamond coredrill.

(3) Position beams under the slab. This could be done with some difficulty by passing them through the opening with a crane. An alternative is to float them into position.

- (4) Install bolts and bearing plates to secure the beams.
 - (5) Cut the timbers to fit snugly into the damaged areas.
 - (6) Install "J" bolts to secure the timbers to the beams. "J" bolts are routinely used by railroads to secure timber ties to steel stringers.
 - (7) Cover the repair with layers of plywood to protect the protruding bolts from damage. The result is a flush repair that will not hinder container handling.
 - (8) Disadvantages are that the edges of the crater must be cleaned, underslinging the beams is difficult, and no preassembly is possible. Several different operations and several different components are required to make the repair. The repair must be custom-built, which requires more supervision.
 - (9) Another alternative was developed to answer objections to the previous alternative. Panels may be prefabricated and transported to the repair area and laid on top of the deck over the repair area with access ramps provided. If time permits, a flush repair may be provided by attaching bearing assemblies to pile caps or to the bottom of the deck. These panels may be preassembled and stockpiled before they are needed. Preassembly may occur in back areas while clean up and cutting proceed on the wharf.
- e. **Steel Beam and Steel Bar Grate Concept.** Steel bar grate is occasionally used as a deck material on draw bridges. It could replace timber decks for expedient repair purposes. An equivalent repair made with bar grate instead of timber will handle the same or more shipping tonnage and less shipping cubage. Bar grate has only one-way structural resistance, and composite action cannot develop between the bar grate and supporting beams. Bar grates can carry container-handling vehicles over 2- to 6-foot spaces between supporting beams.
- f. **Prestressed Concrete Girder Concept.** Prestressed concrete slabs and box beams are most useful when custom-made for a specific wharf and stored nearby. After a prestressed girder has been cast, it is impossible to trim it in the field. The beams must be handled carefully. They will crack if they are not set and lifted properly. If a precasting plant is available near the port, prestressed beams could be cast and cured in seven days. If high-strength concrete is used, the beams cure to the required strength sooner. Given favorable circumstances, beams may be ready for use 24 hours after casting.
- g. **Railroad Flatcars Concept.** Railroad flatcars are designed to carry trucks used in intermodal (piggyback) service. A typical piggyback, 9-foot wide flatcar is 90 feet long and spans 66 feet between truck centers. The cars should be taken off their trucks and mounted on bearing assemblies that simulate truck centers. The cars would rest on the undamaged portion of the deck. End ramps would be necessary. Container-handling vehicles might also be accommodated if two railroad cars are laid side by side, and the vehicle is driven with one wheel on each railroad car.
- h. **Sheet Pile Concept.** Sheet piling may be driven to form a sheet the shape of the crater in the deck. This cell could be filled with suitable rubble to the level of the finished deck. Time to construct such a cell could, however, be excessive.

EXPEDIENT MARINE RAILWAY CONSTRUCTION

Marine railways consist of inclined groundways extending into the water, cradles moving on ground-way tracks, wheels attached to the cradles, roller trains not attached to the cradle or the track, hoisting machinery, and chains or cable for hauling the cradles into and out of the water. The railways are used to haul ships out of the water for repairs. In the TO, large commercial marine railways require excessive time and skilled personnel support. They are expensive and unsuitable for expedient military construction. An example of an expedient military marine railway for small craft is a string of Navy pontoons equal in length to the railway required. Rails are bolted to the pontoons which are, in turn, towed to a foundation and sunk in place.

MARINE LIFTS

Another substitute for commercial marine railways, in addition to Navy pontoons, is the marine lift. Building a marine lift, also called a vertical lift or elevating platform, does not involve the extensive or expensive underwater work involved in building marine railways. The lift has a movable platform supported in a slip between rows of piles or columns. The hoisting gear, resting on these supports, raises or lowers the cradle or platform. In operation, the vessel is floated into position over the platform and lifted vertically to the desired elevation, where it is repaired in place. A separate cradle on wheels can be rolled to another position. Some marine lifts can transfer vessels from their lifts to desired repair locations using a wheeled carriage and rail-transfer system. The transfer may be both longitudinal and sideways. This permits quick movement of vessels to specialized repair areas.

APPENDIX A EXPEDIENT CONSTRUCTION DETAILS

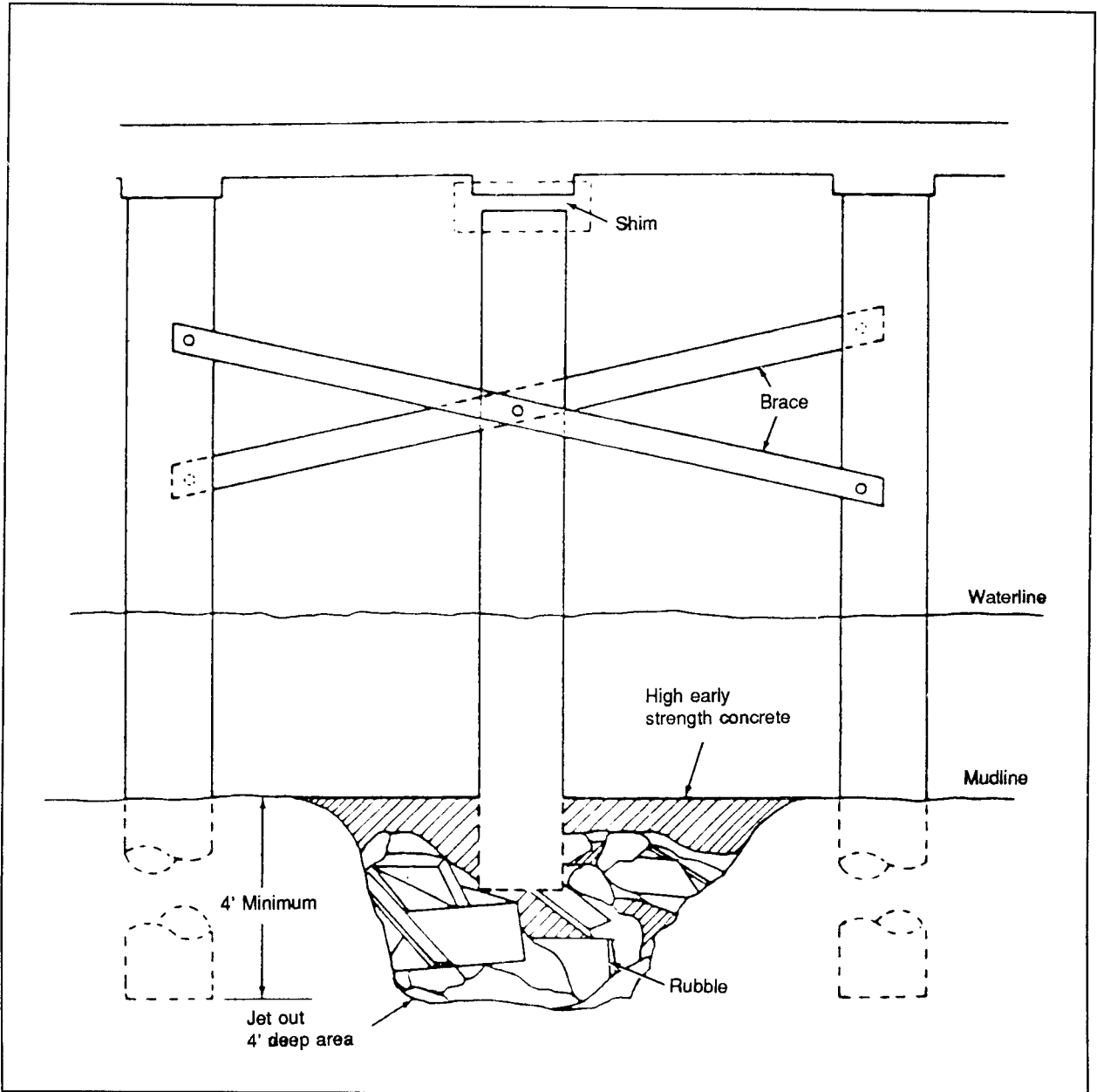

Figure A-1. Rubble Foundation

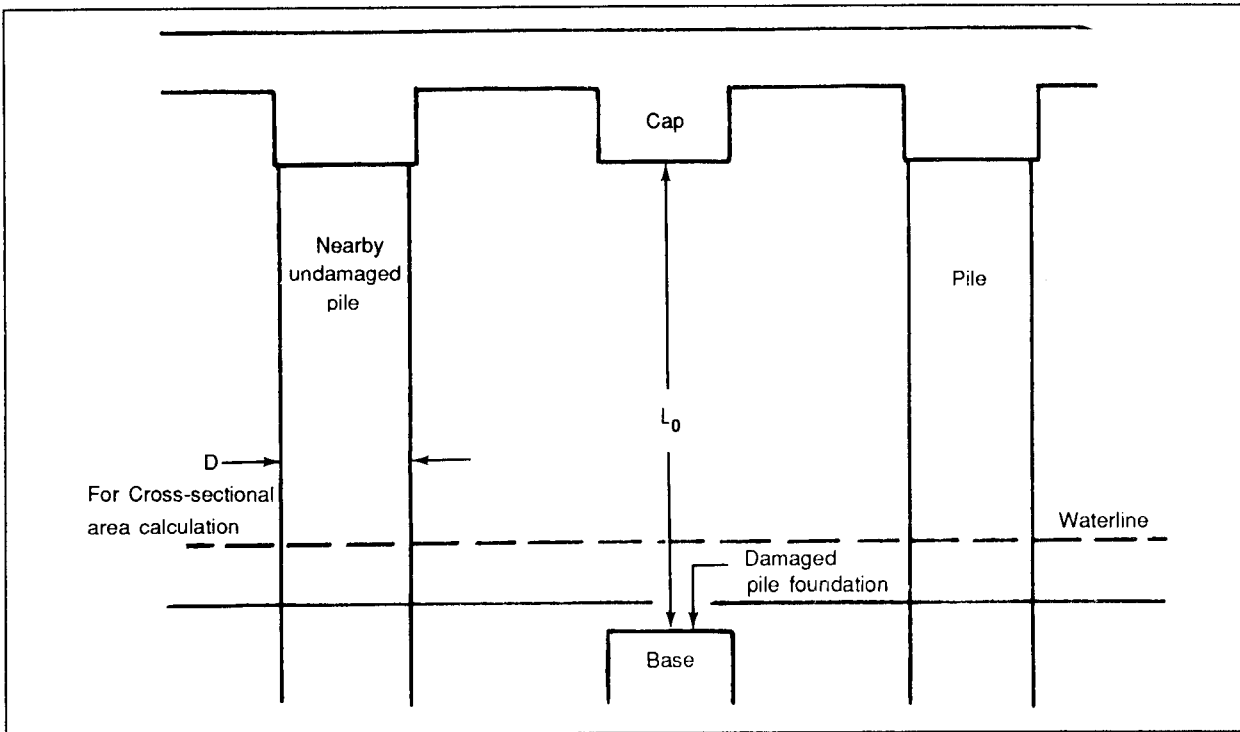

Figure A-2. Structural Elements of Pier or Wharf with Damaged Pile

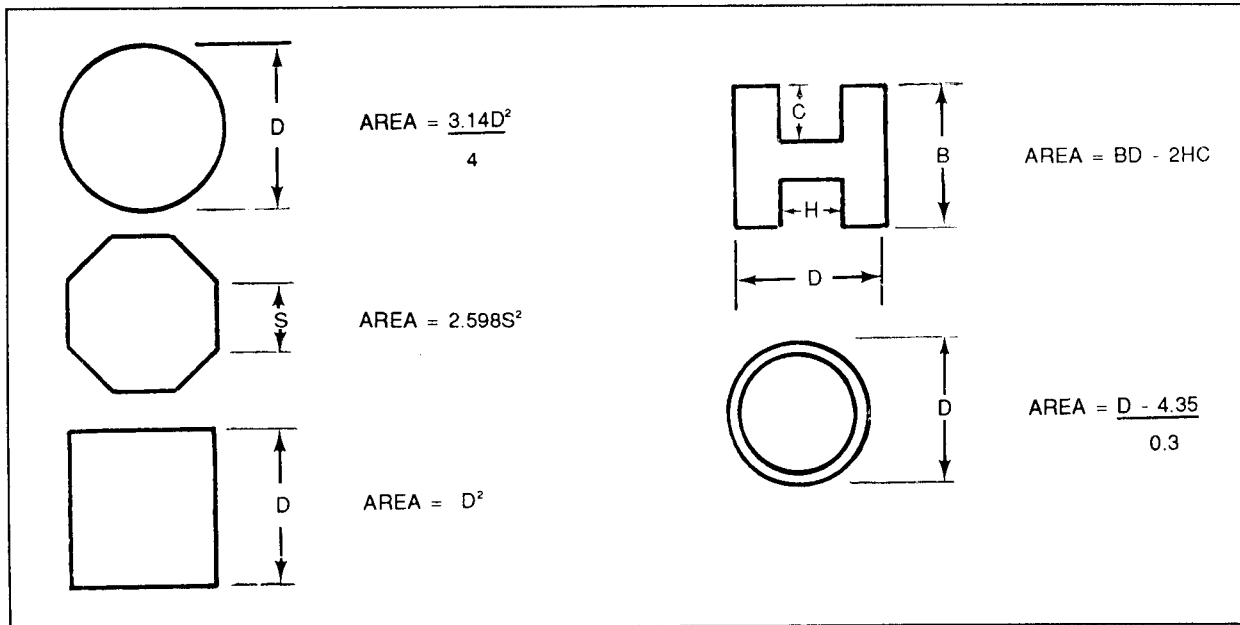

Figure A-3. Cross-Sectional Area Formulas for Adjacent Pile

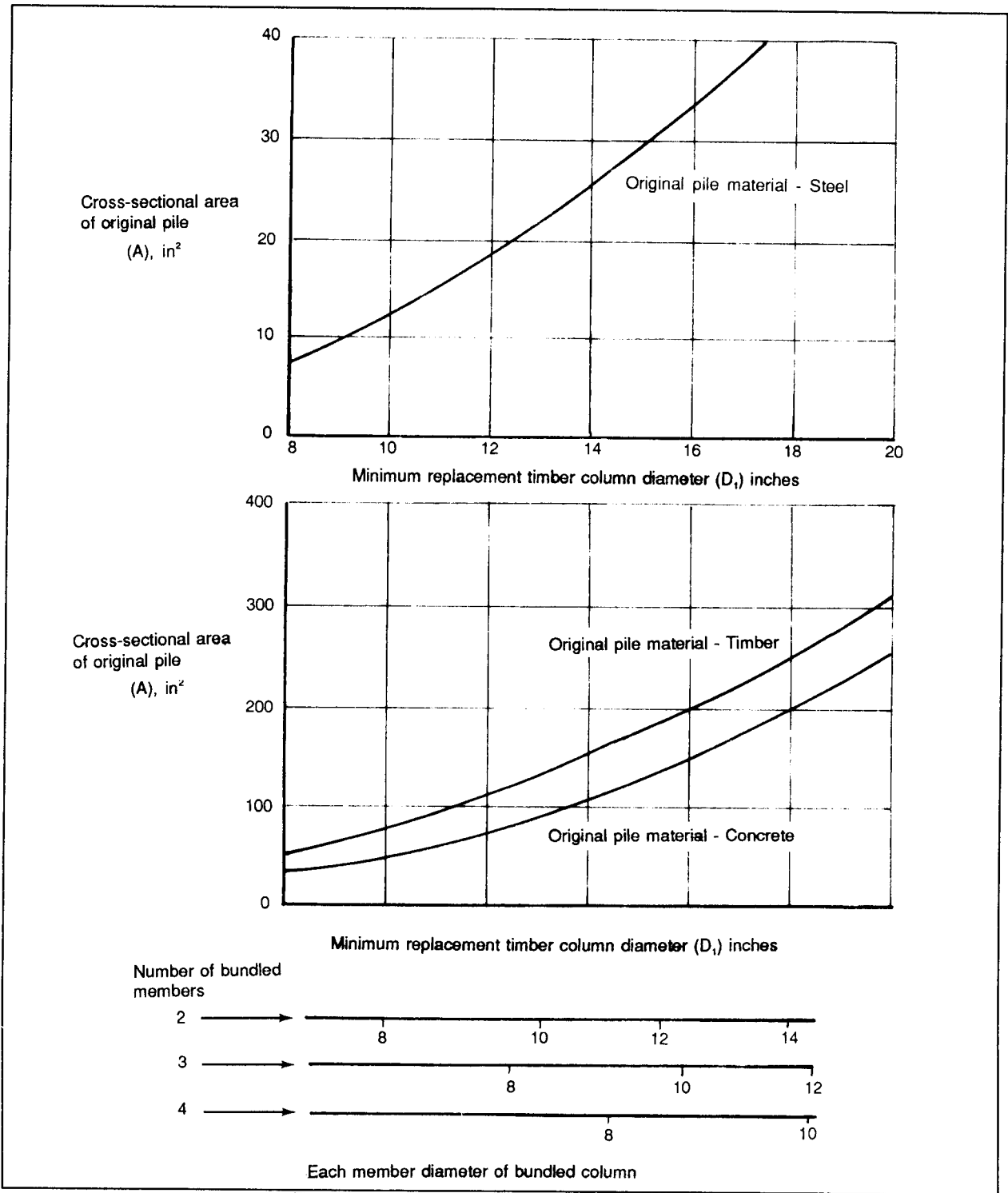

Figure A-4. Replacement Timber Diameter Determination

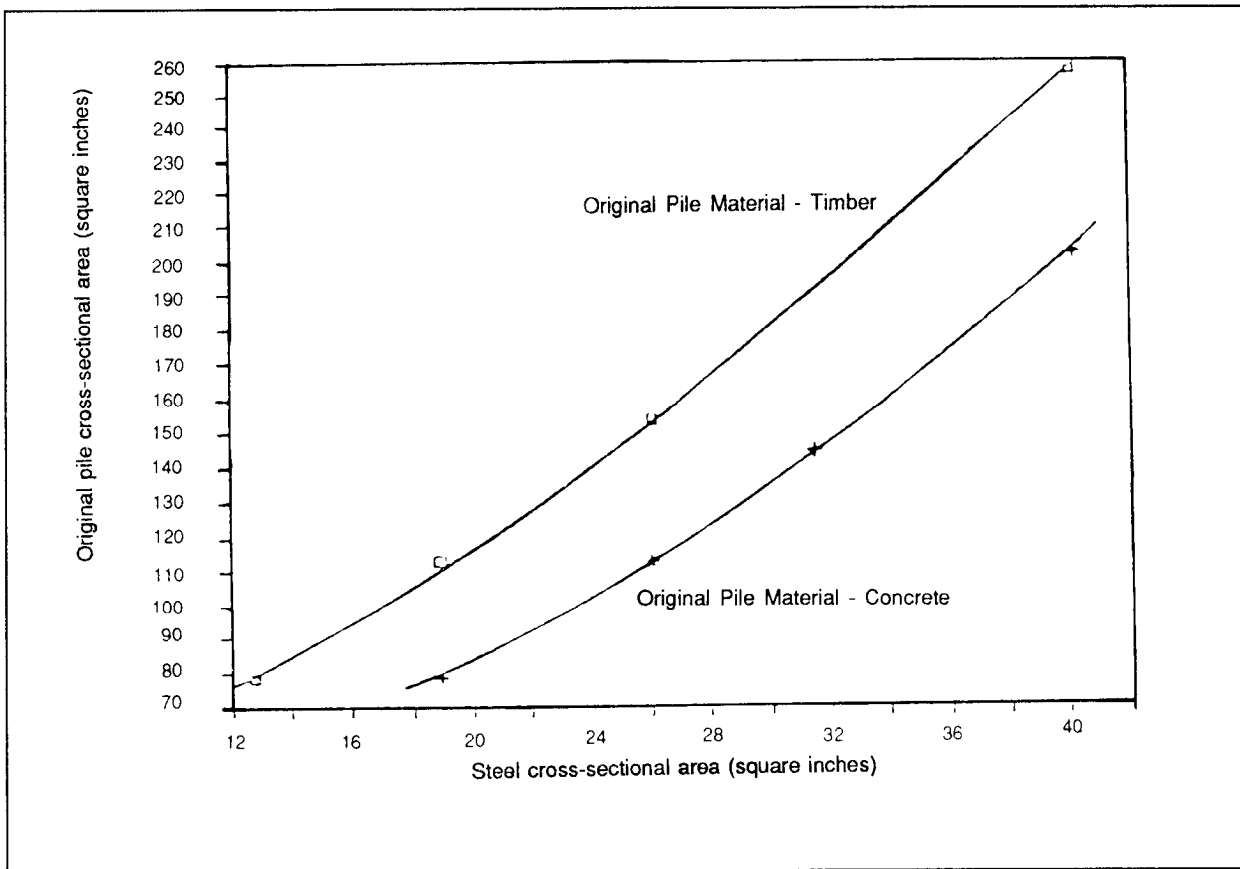

Figure A-5. Equivalent Steel Cross-Sectional Area

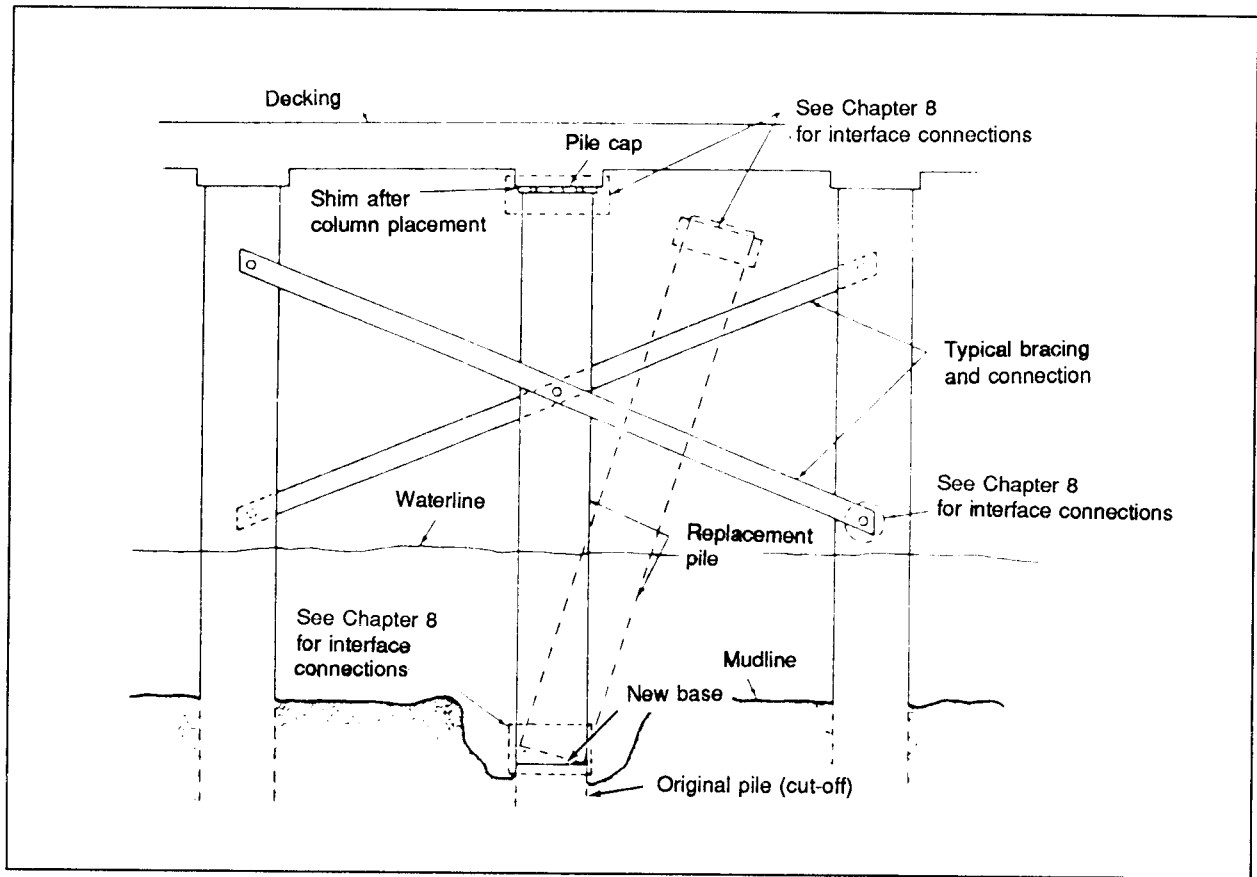

Figure A-6. Wood Columns

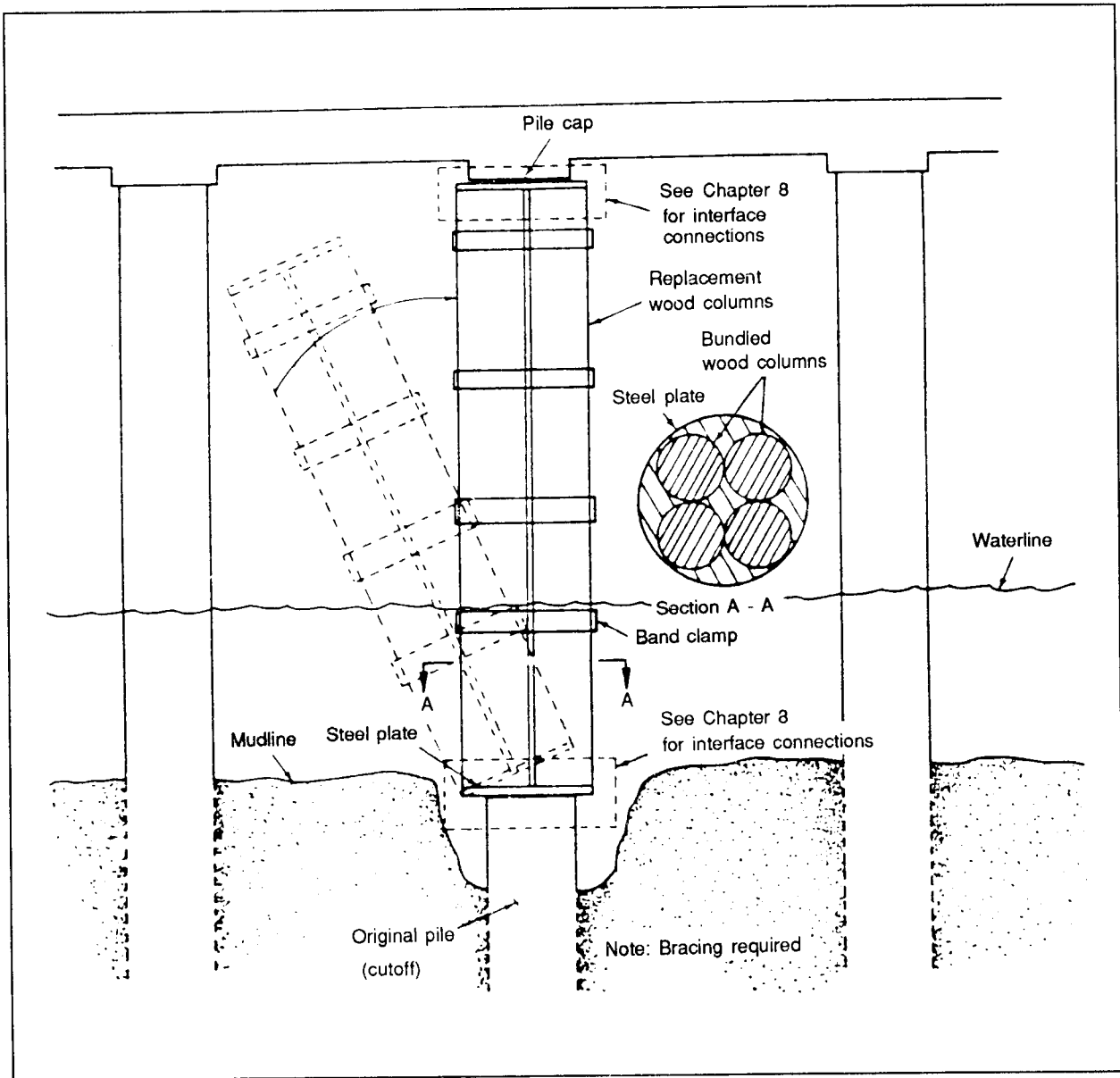

Figure A-7. Bundled Wood Columns

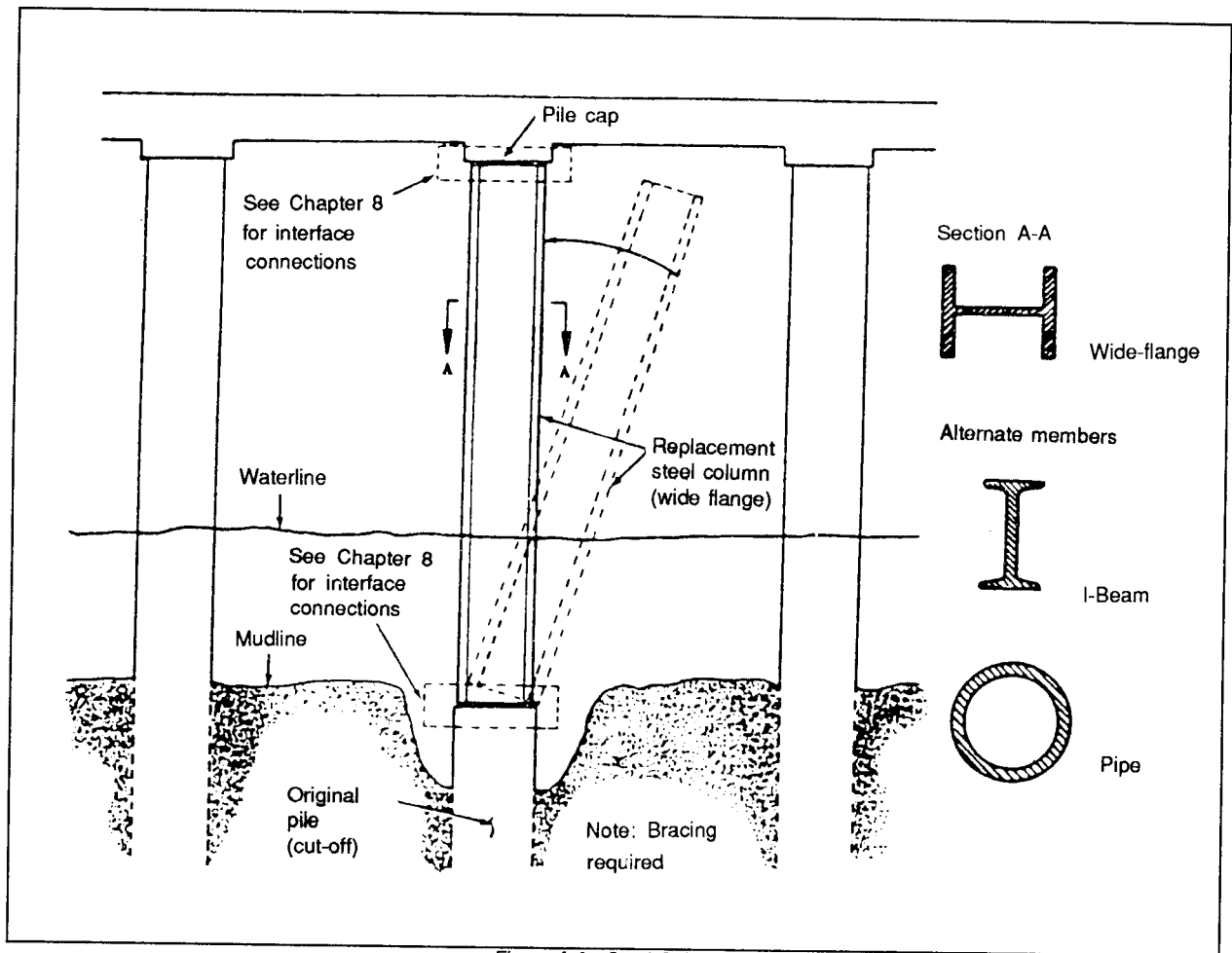

Figure A-8. Steel Columns

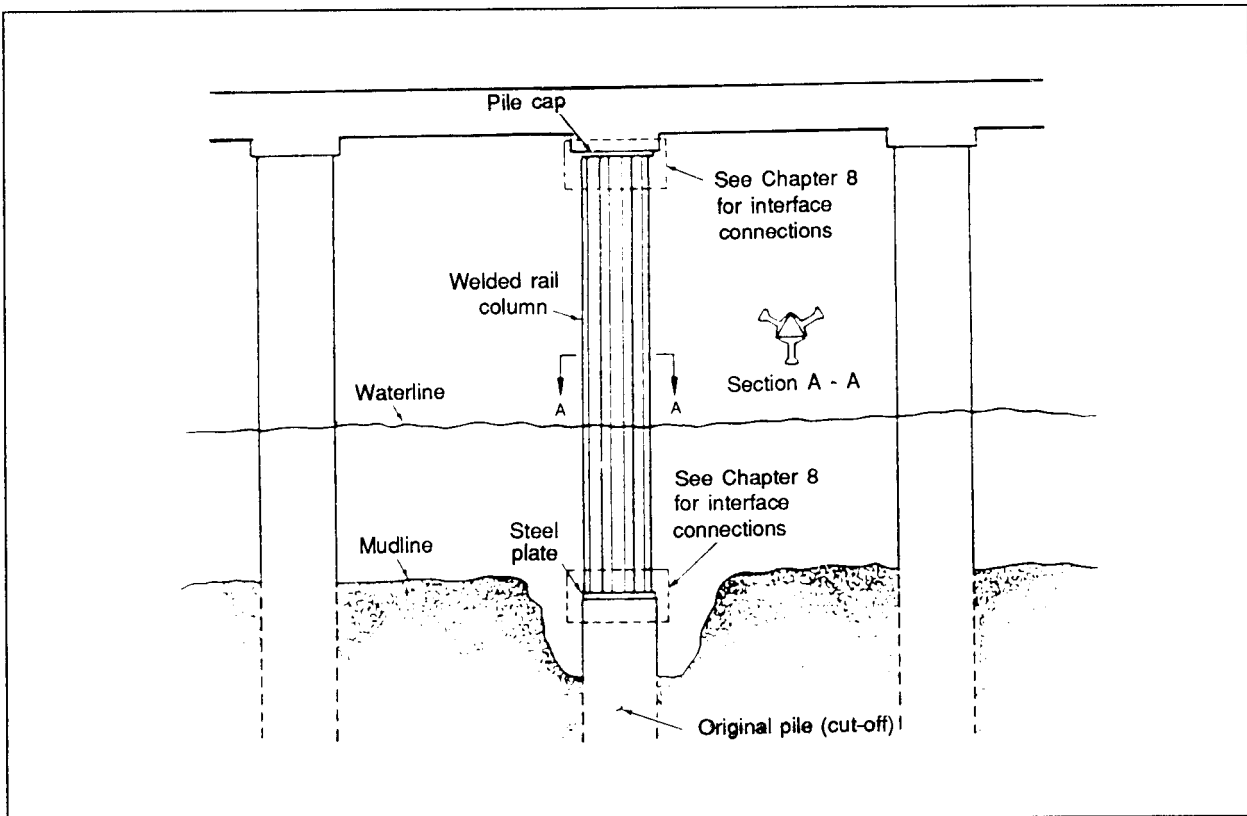

Figure A-9. Welded Steel Rail Column

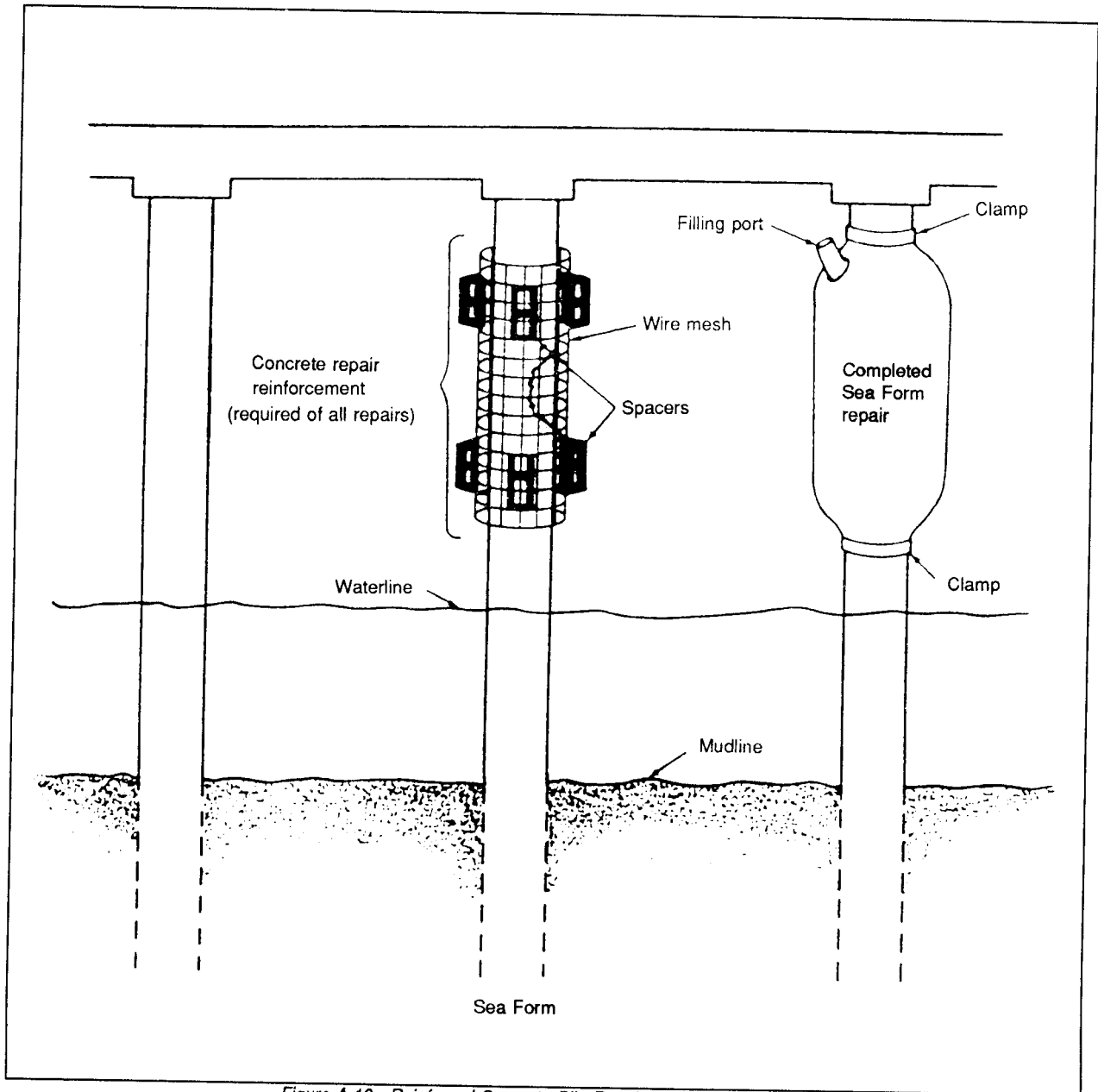

Figure A-10. Reinforced Concrete Pile Repairs Using "Sea Forms"

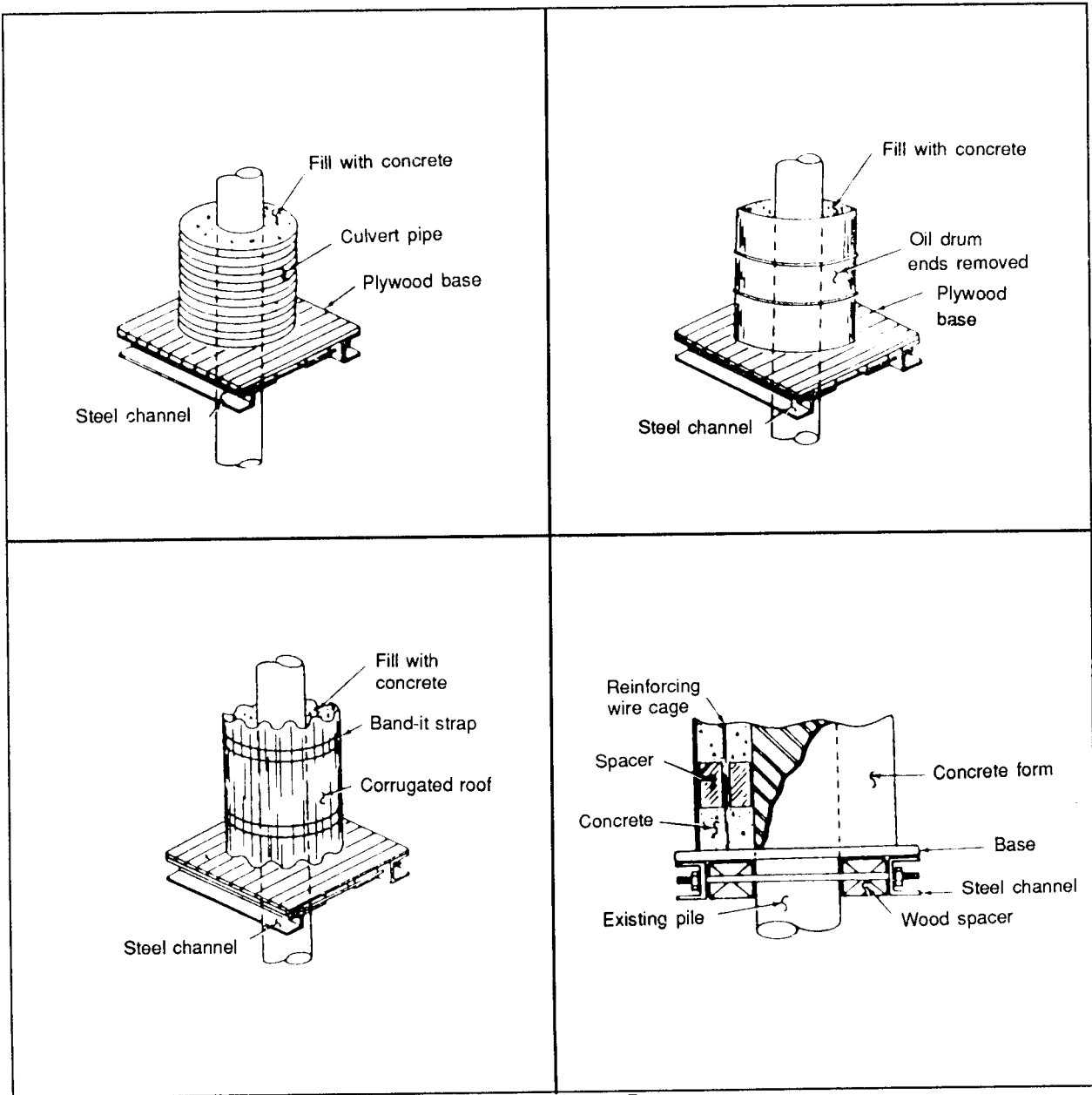

Figure A-11. Alternate Forms

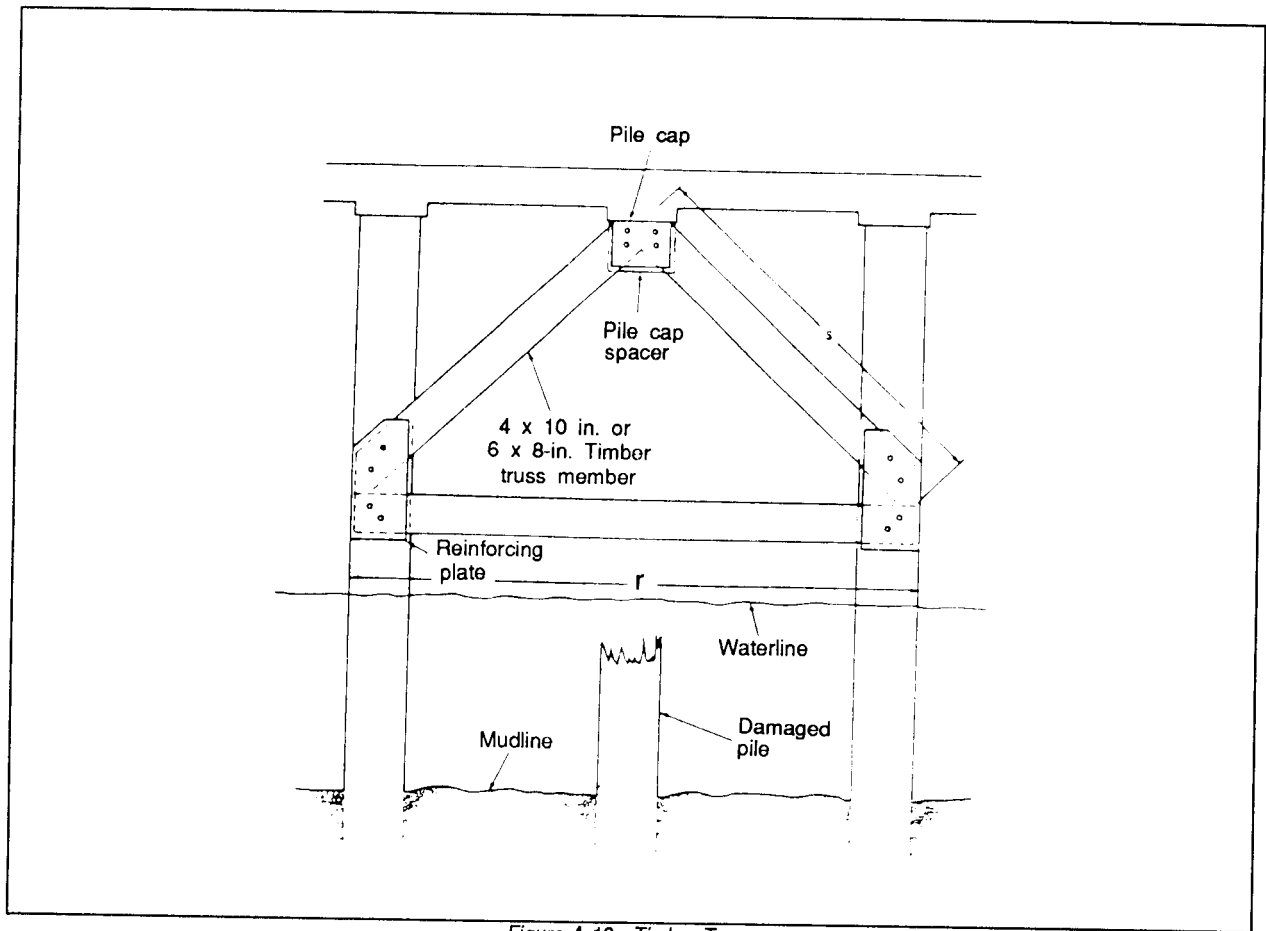

Figure A-12. Timber Truss

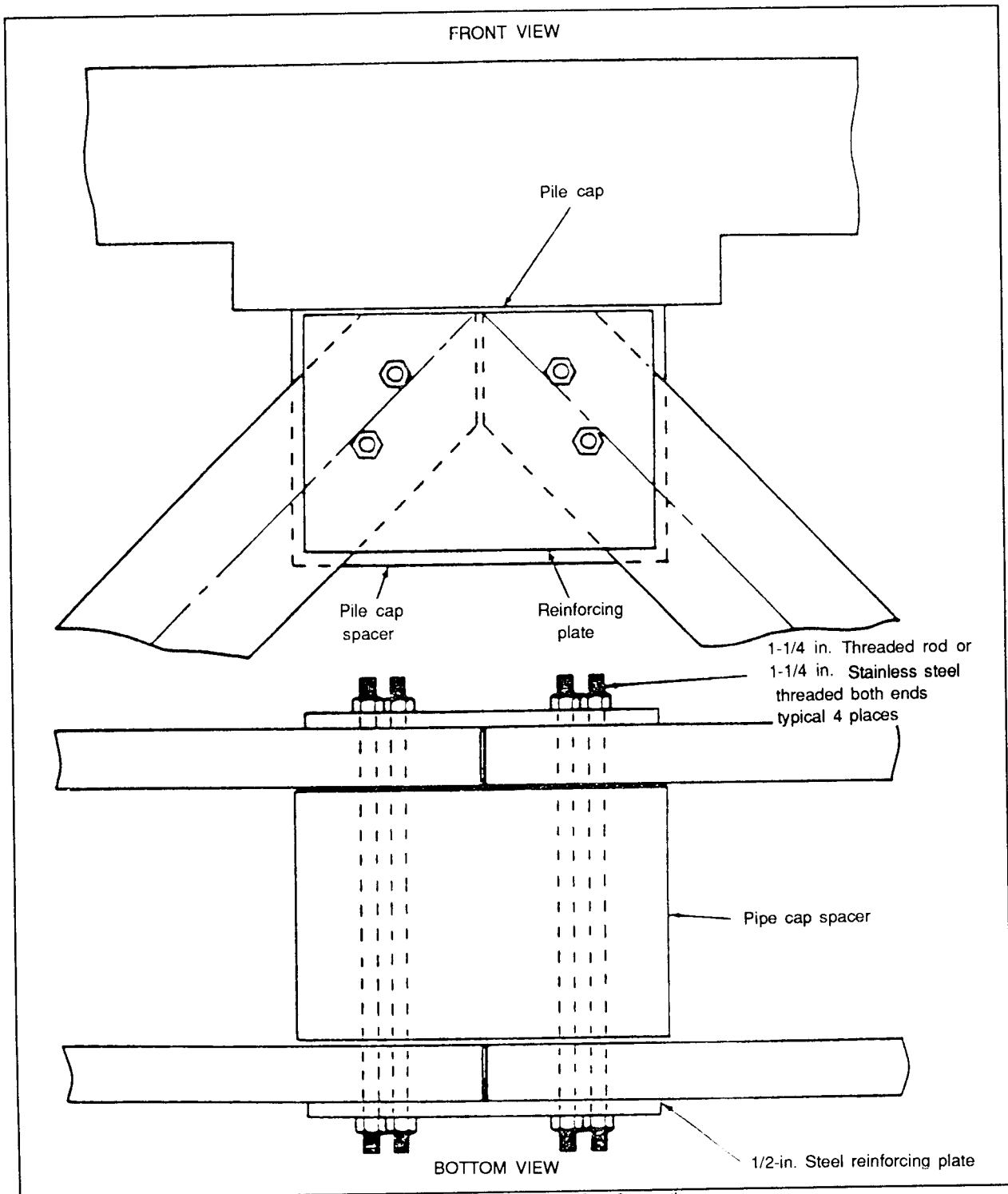

Figure A-13. Timber Truss Pile Cap Connection

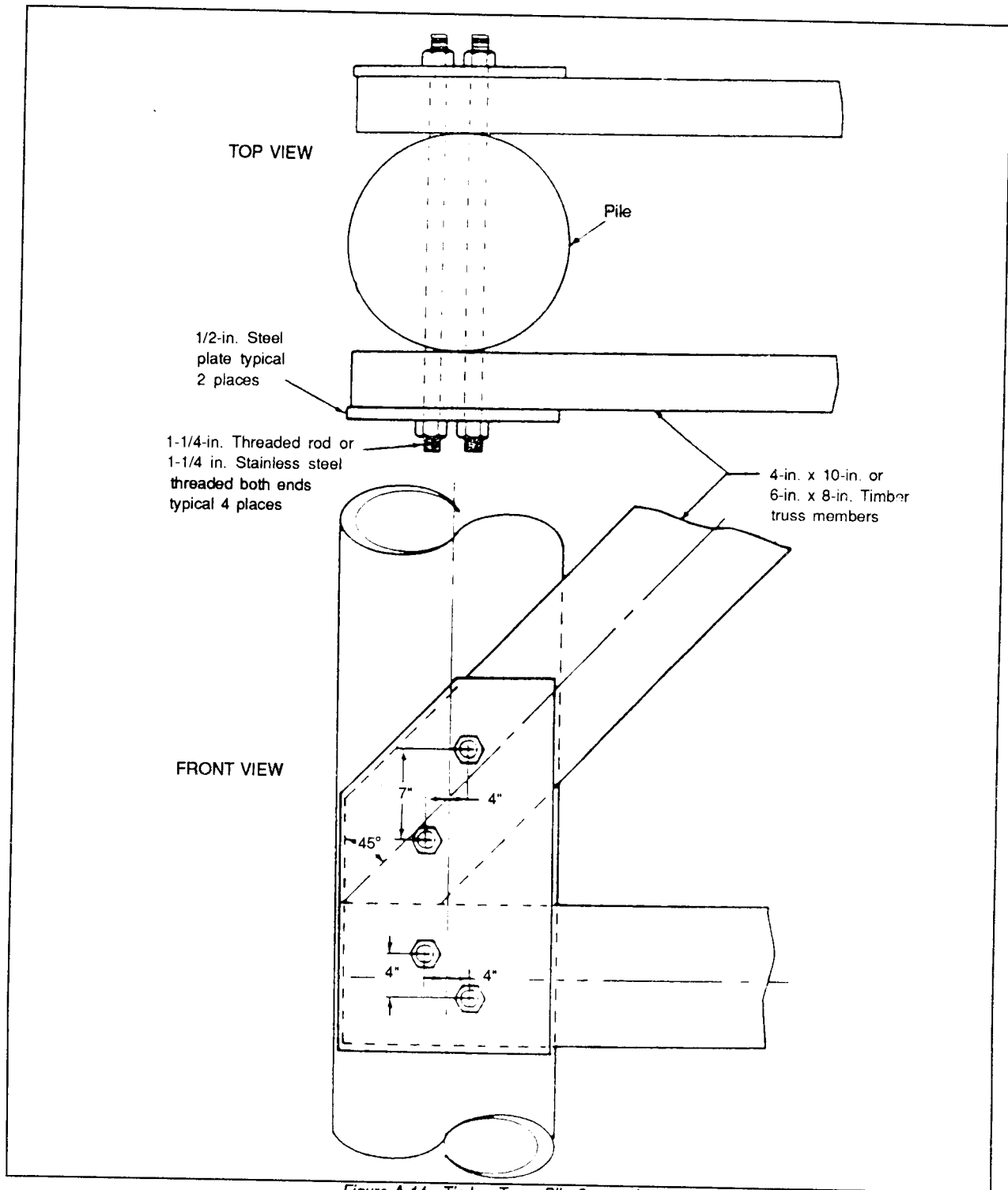

Figure A-14. Timber Truss Pile Connection

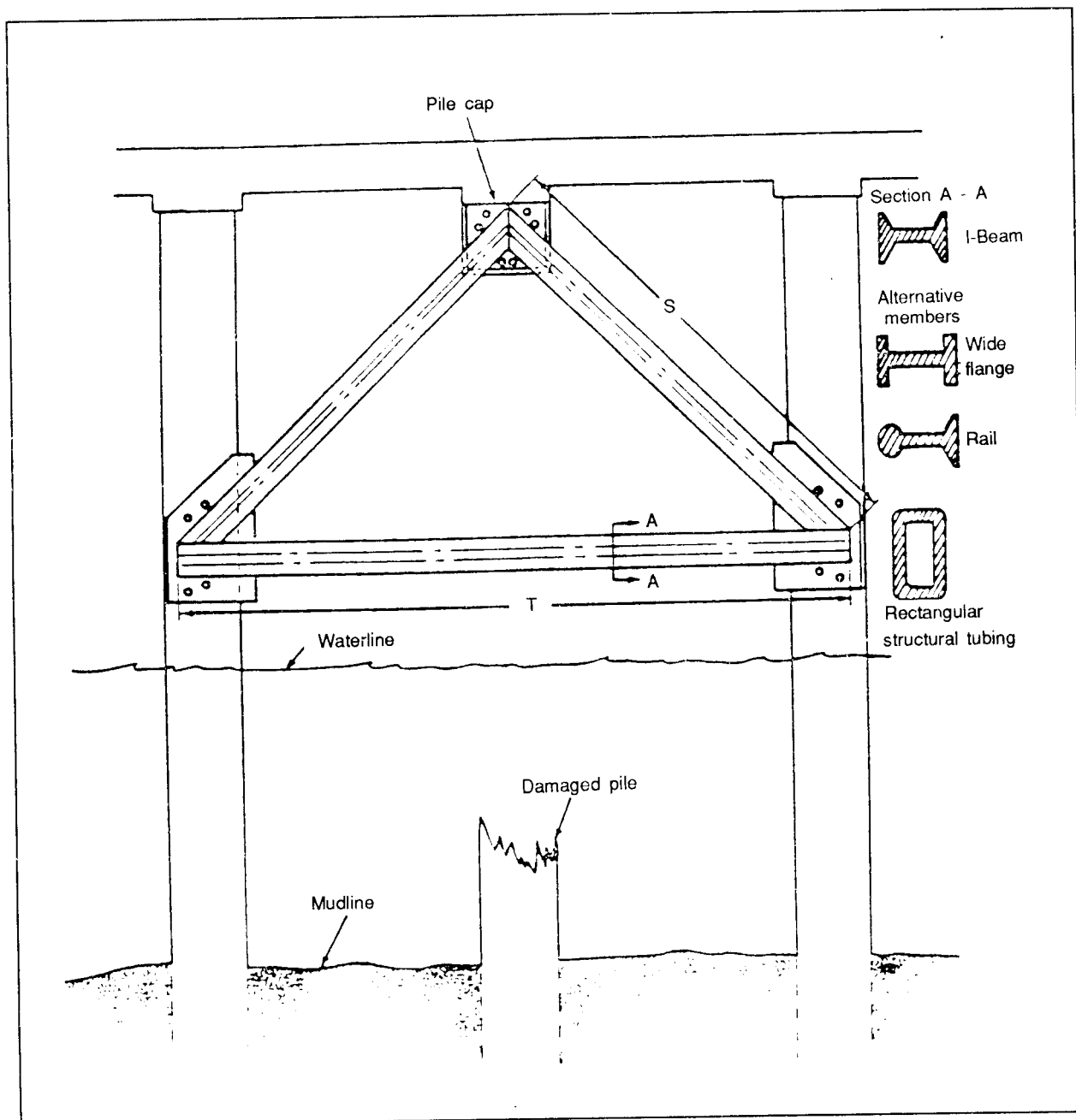

Figure A-15. Steel Truss

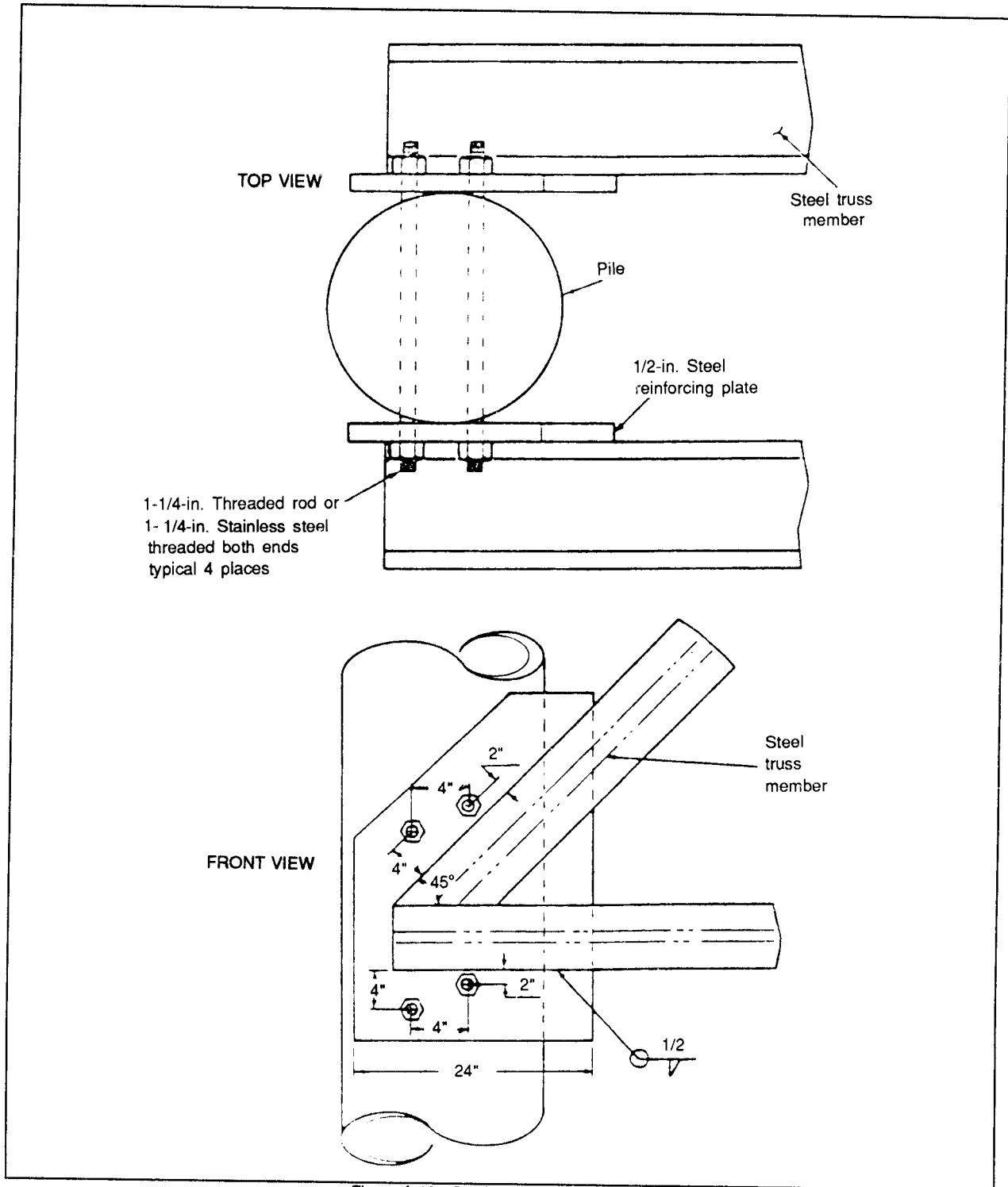

Figure A-16. Steel Truss Pile Connection

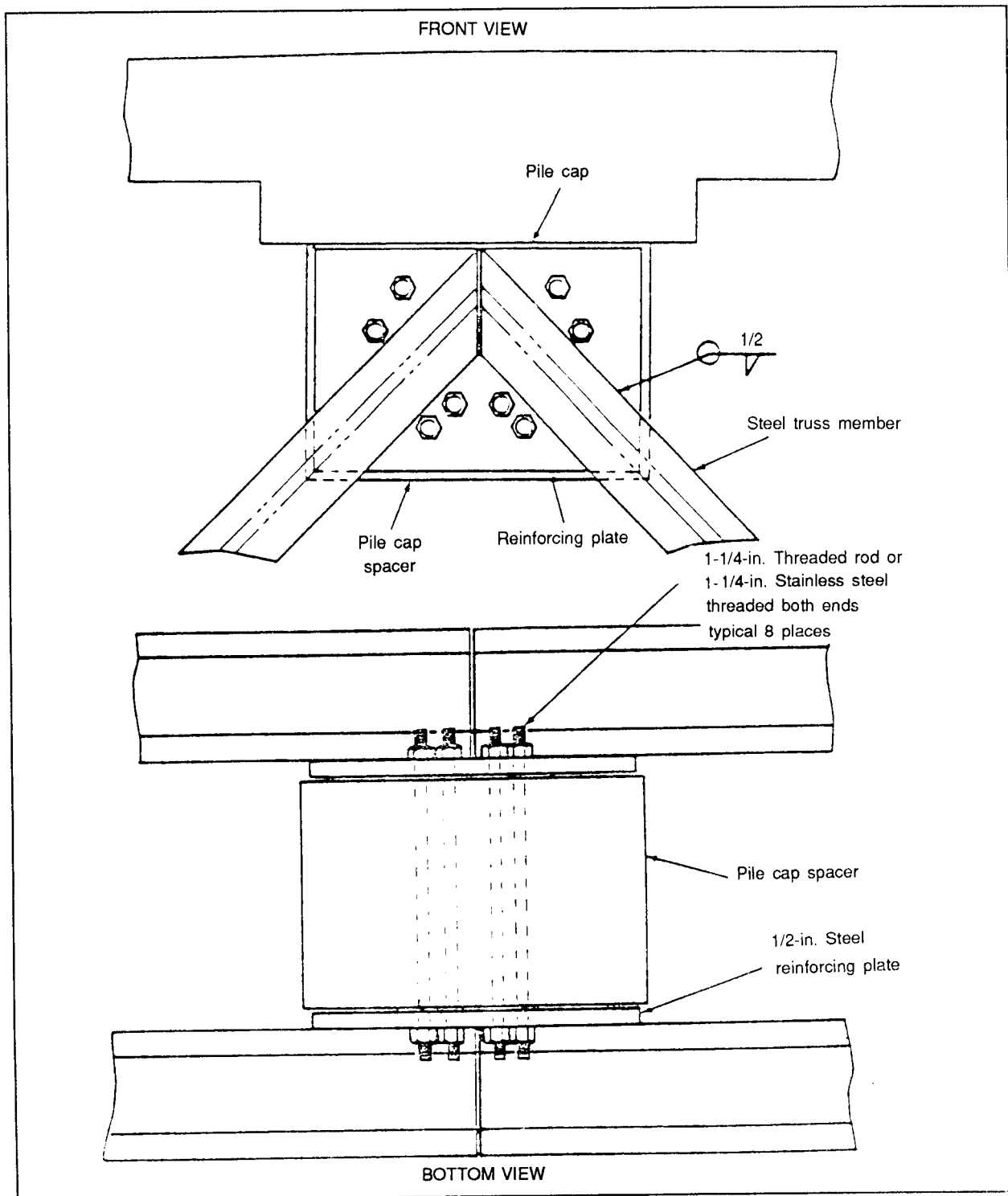

Figure A-17. Steel Truss Pile Cap Connection

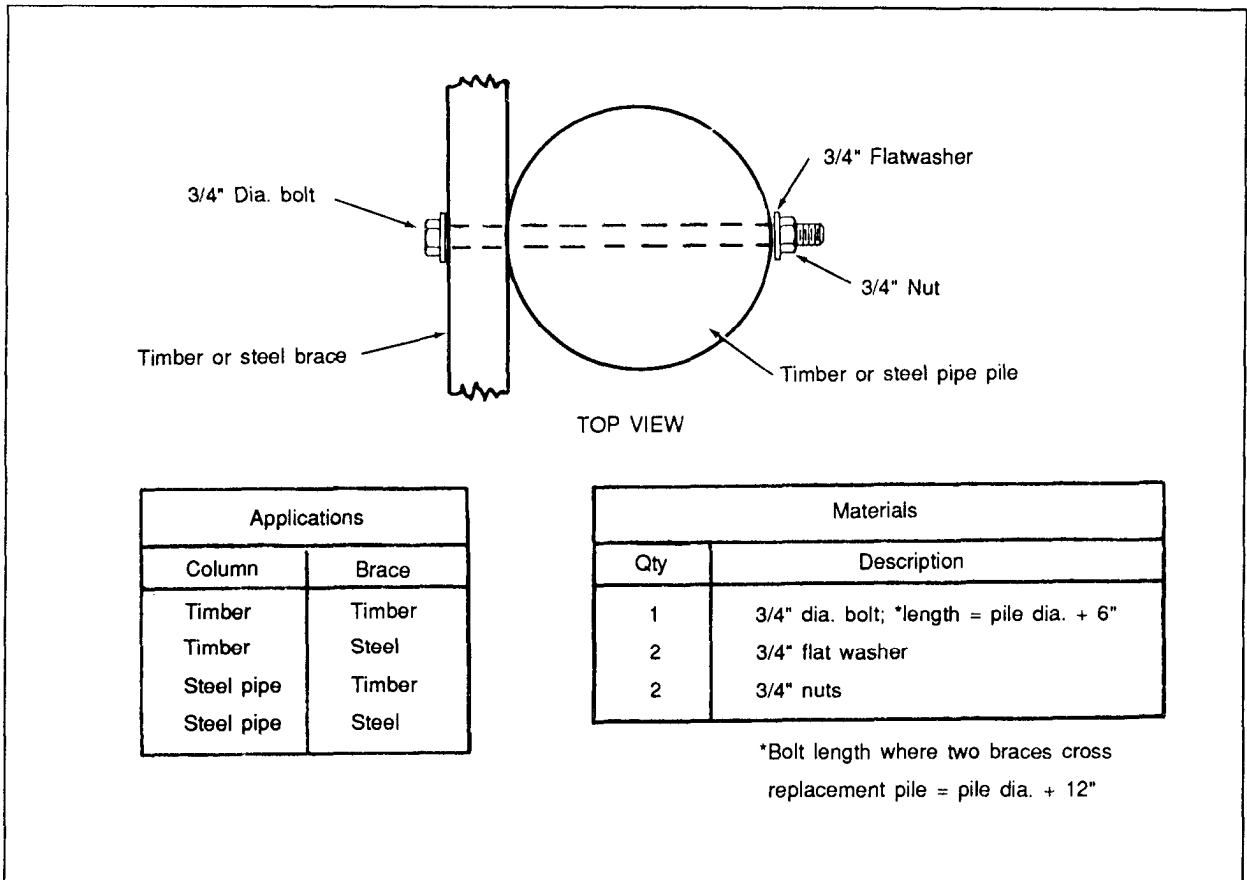

Figure A-18. Brace Connected to Timber or Steel Pipe Pile (Bracing Method 1)

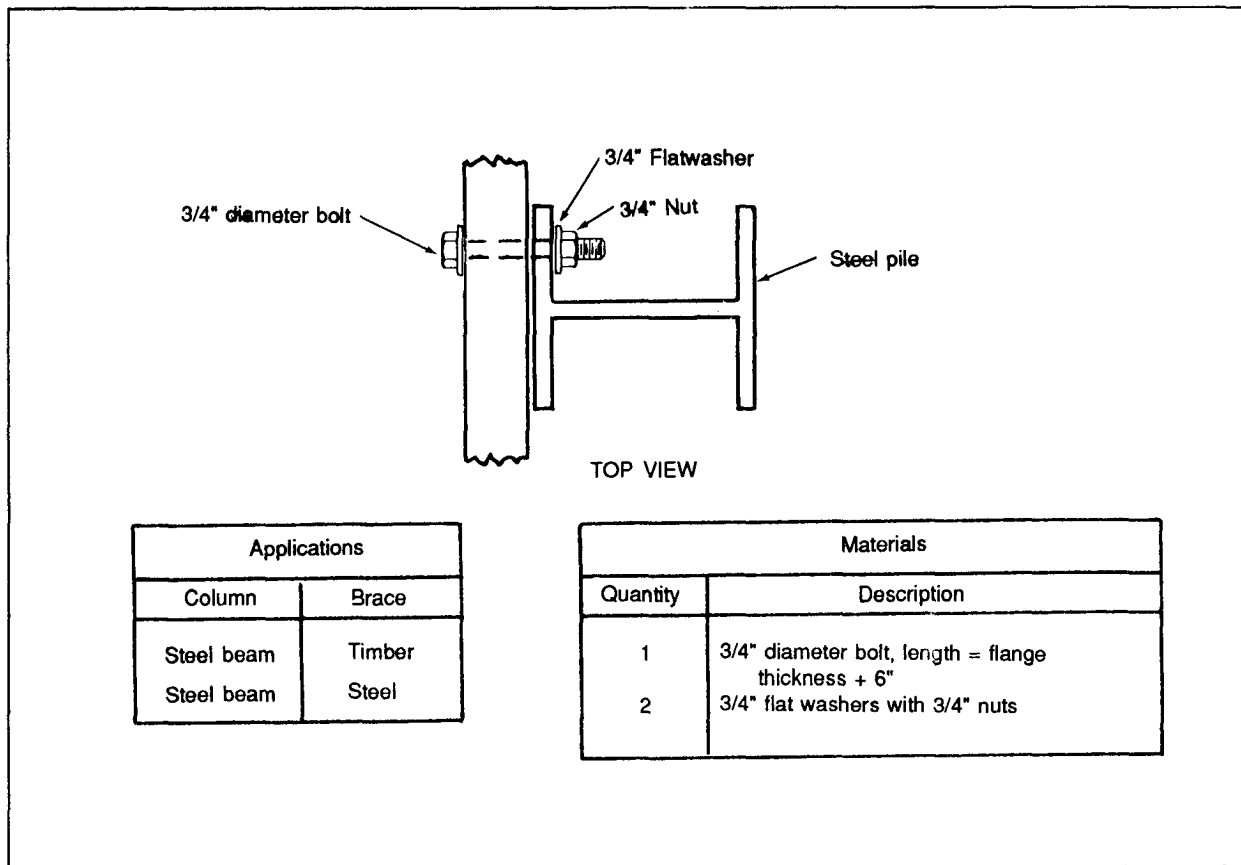

Figure A-19. Brace Connected to Steel Beam Pile (Bracing Method 2)

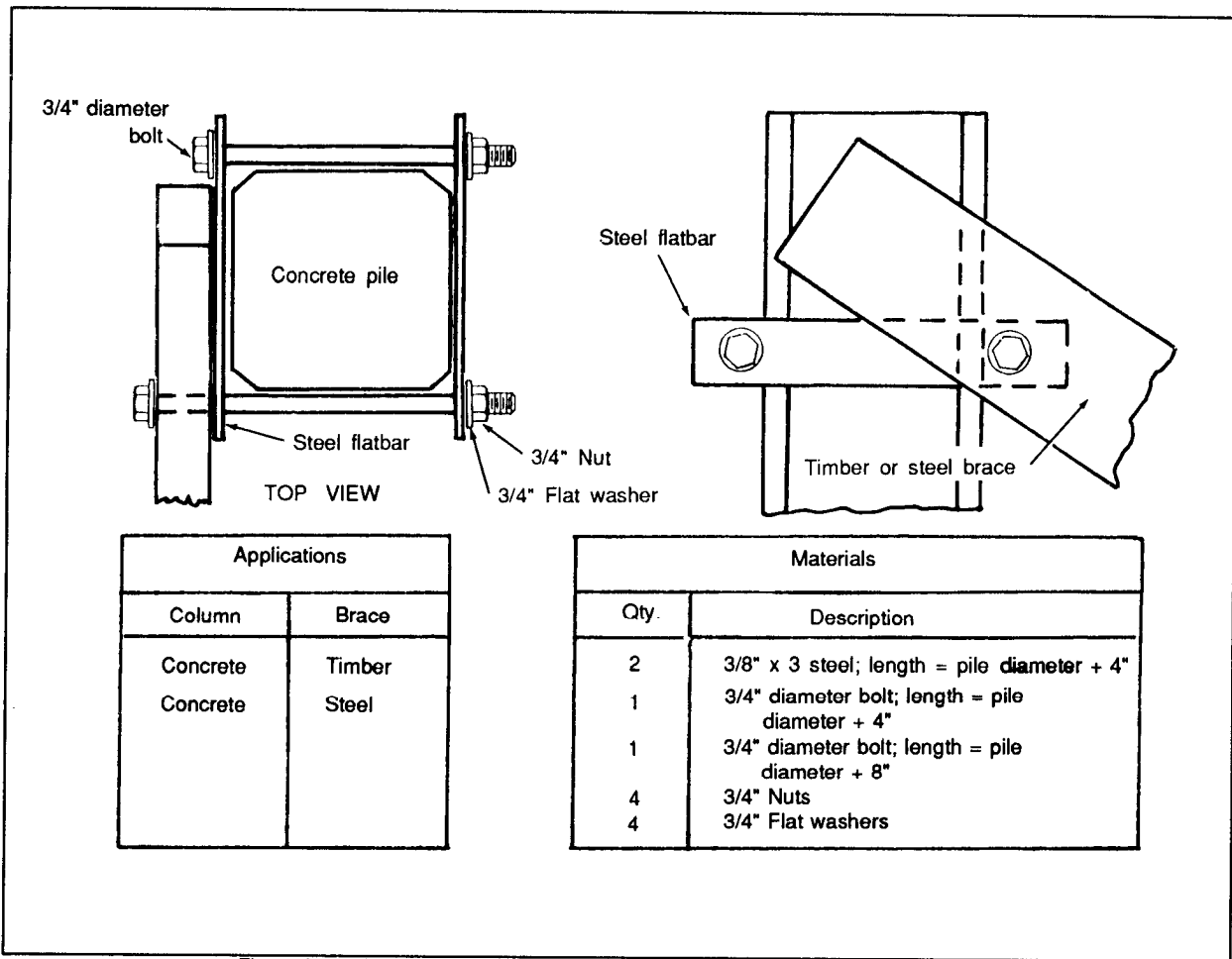

Figure A-20. Brace Connected to Concrete Pile (External Bracket-Bracing Method 3)

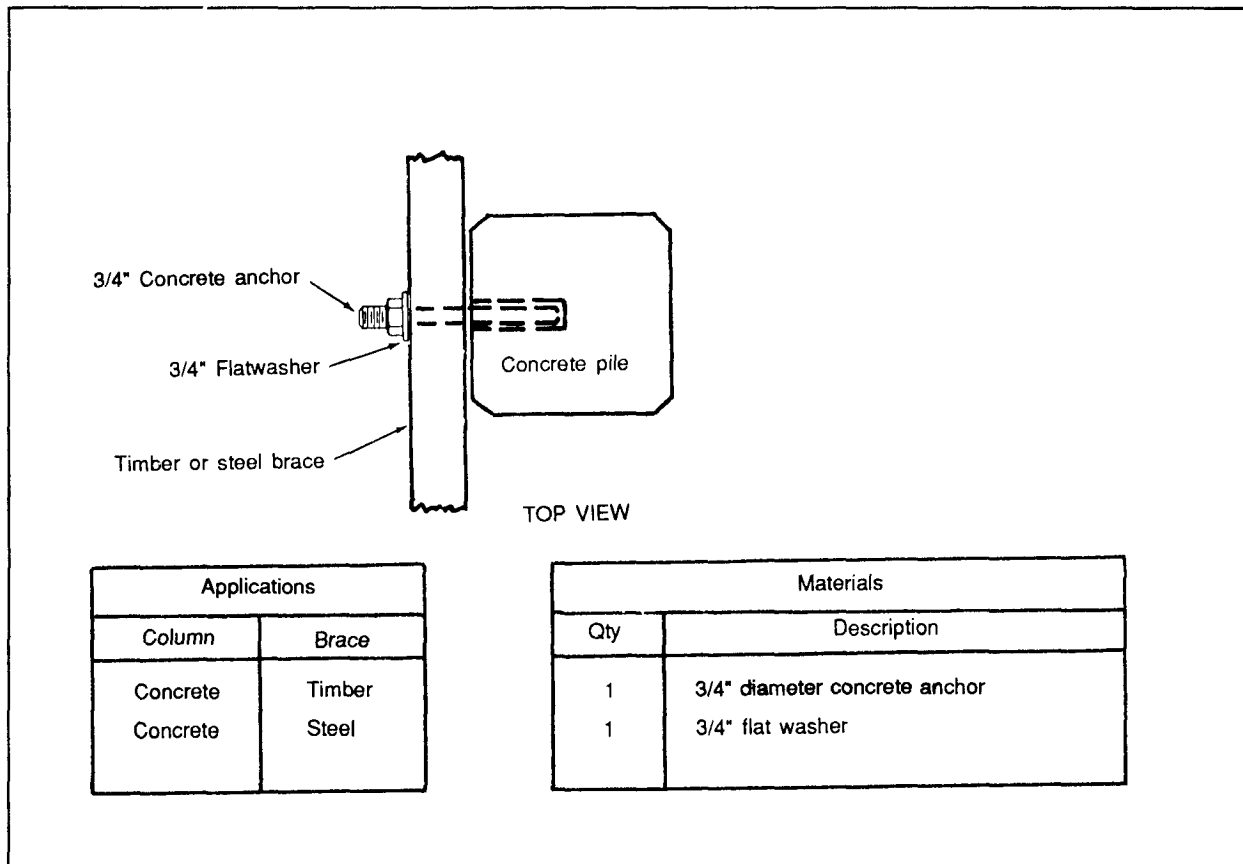

Figure A-21. Brace Connected to Concrete Pile with Concrete Anchor (Bracing Method 4)

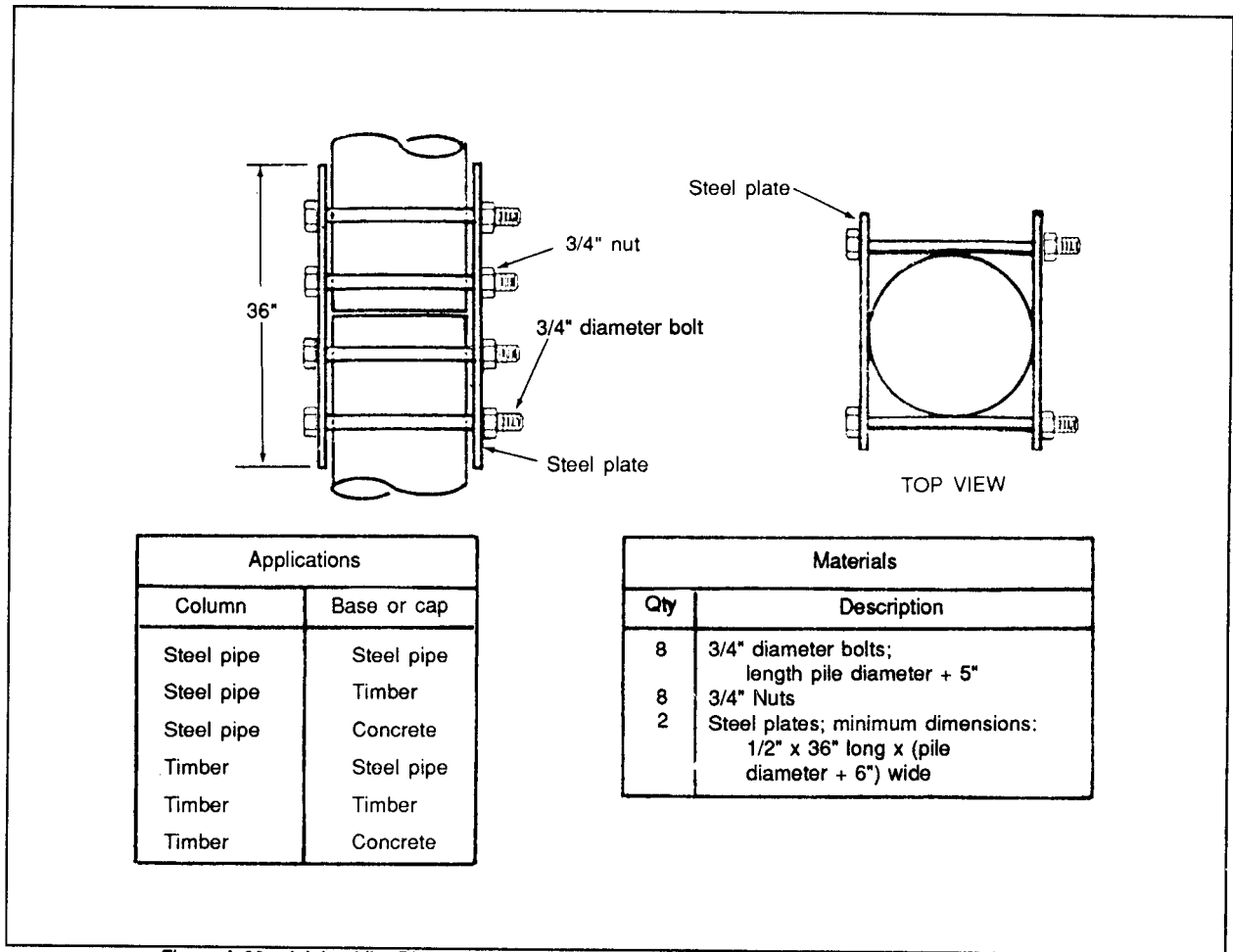

Figure A-22. Joining Like-Diameter Piles, Column to Base or Cap Connections (Connecting Method 1)

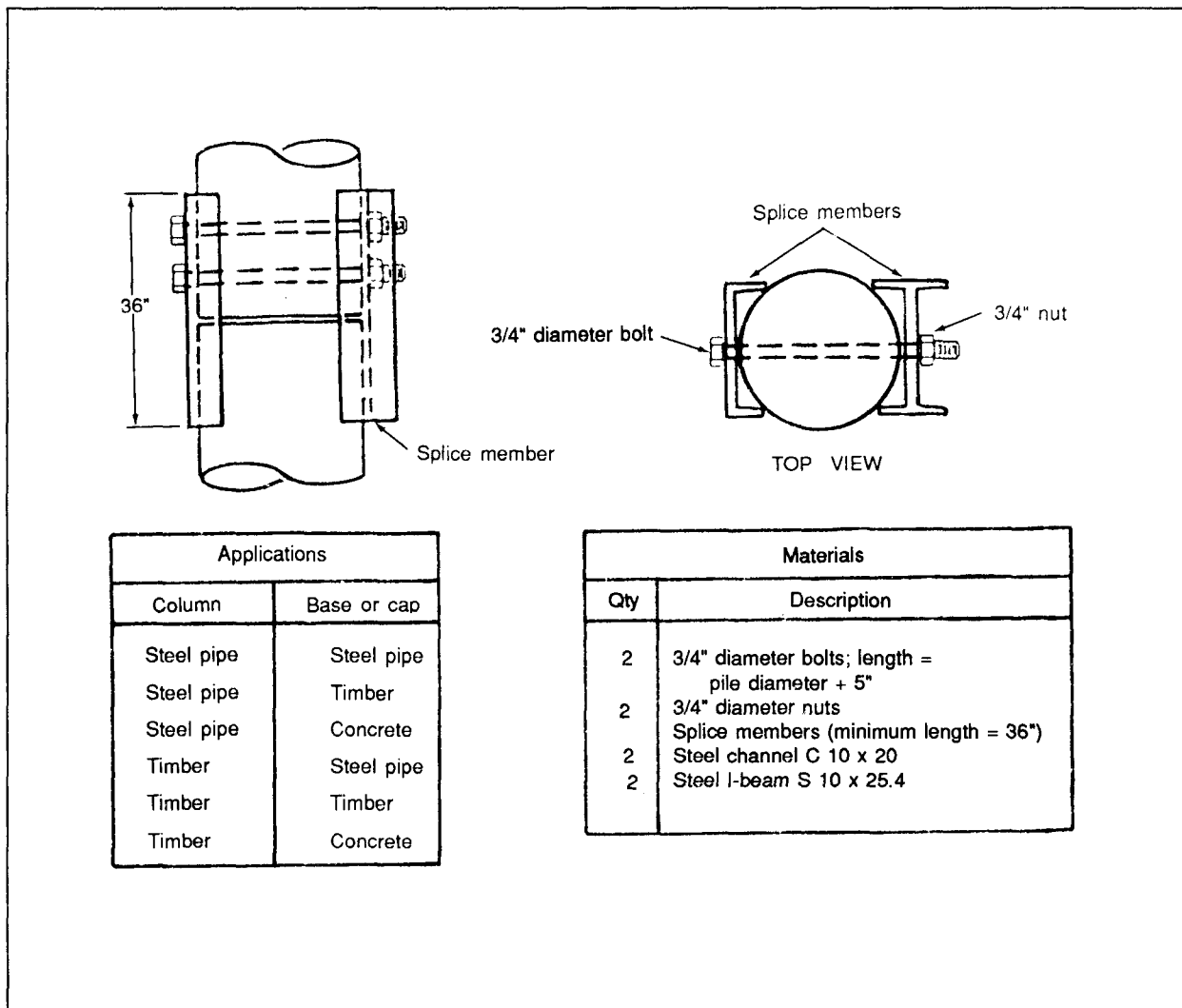

Figure A-23. Joining Like-Diameter Piles, Column to Base or Cap Connections (Connecting Method 2)

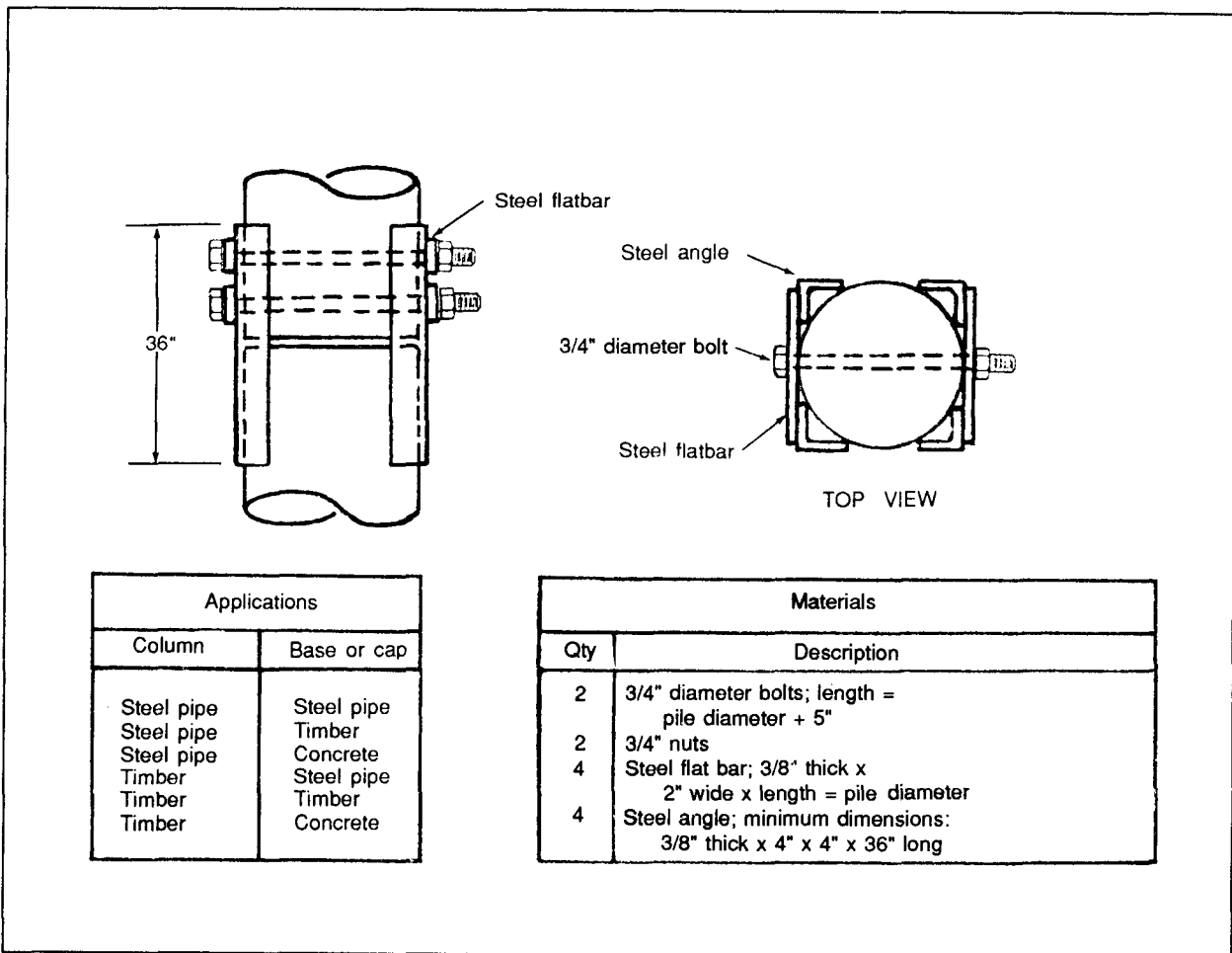
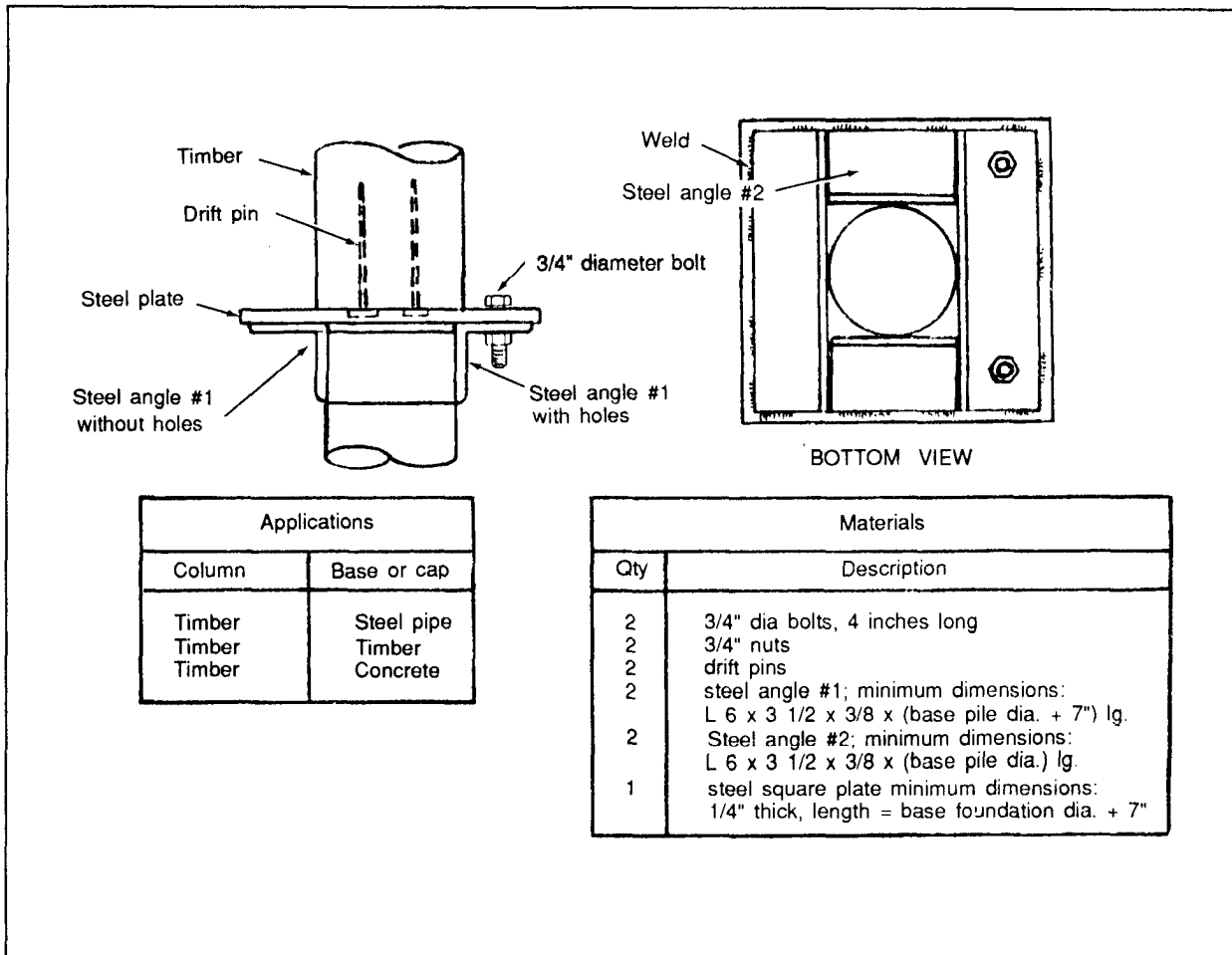

Figure A-24. Joining Like-Diameter Piles, Column to Base or Cap Connections (Connecting Method 3)



Applications	
Column	Base or cap
Timber	Steel pipe
Timber	Timber
Timber	Concrete

Materials	
Qty	Description
2	3/4" dia bolts, 4 inches long
2	3/4" nuts
2	drift pins
2	steel angle #1; minimum dimensions: L 6 x 3 1/2 x 3/8 x (base pile dia. + 7") lg.
2	Steel angle #2; minimum dimensions: L 6 x 3 1/2 x 3/8 x (base pile dia.) lg.
1	steel square plate minimum dimensions: 1/4" thick, length = base foundation dia. + 7"

Figure A-25. Joining Piles of Different Diameter, Column to Base or Cap Connections (Connecting Method 4)

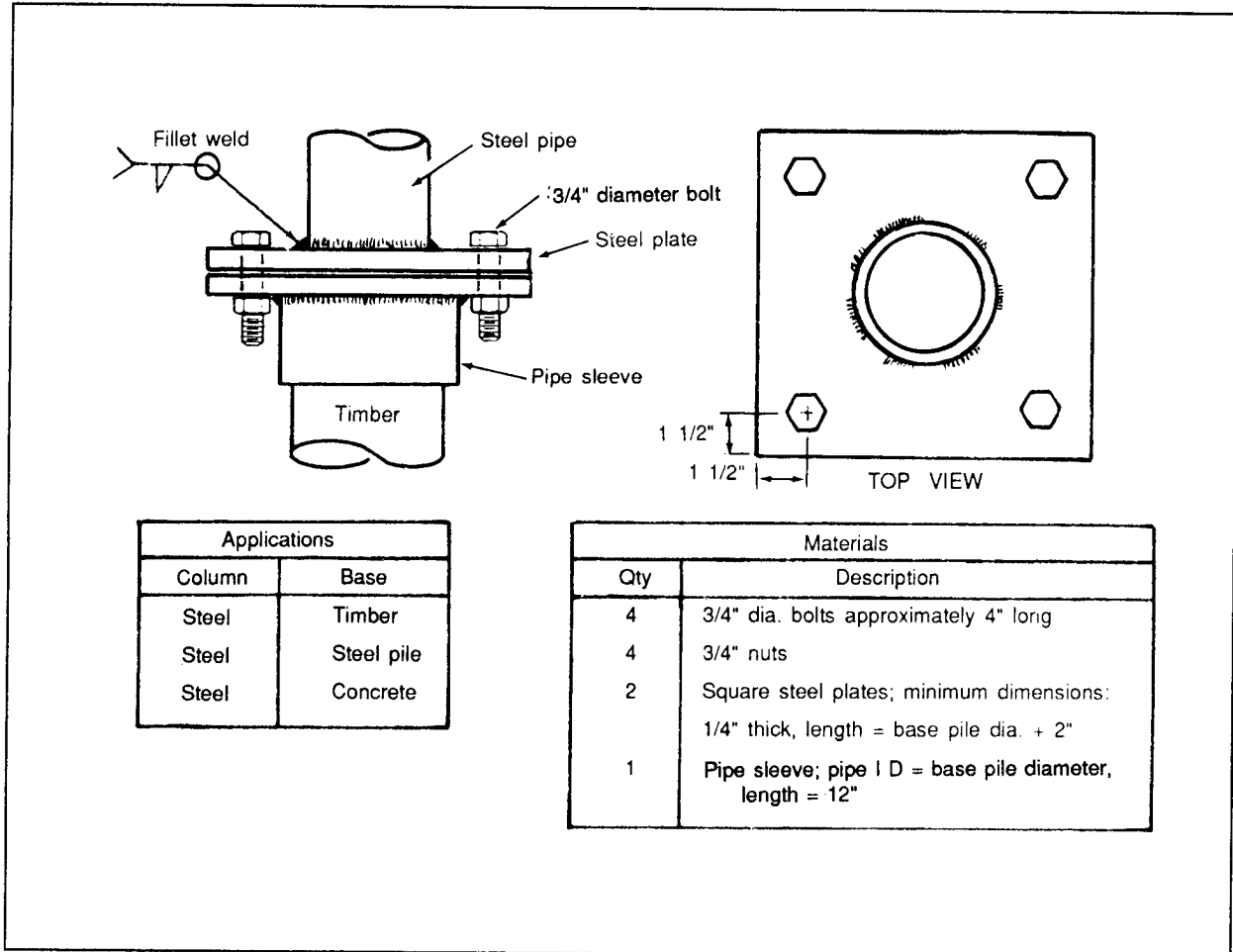
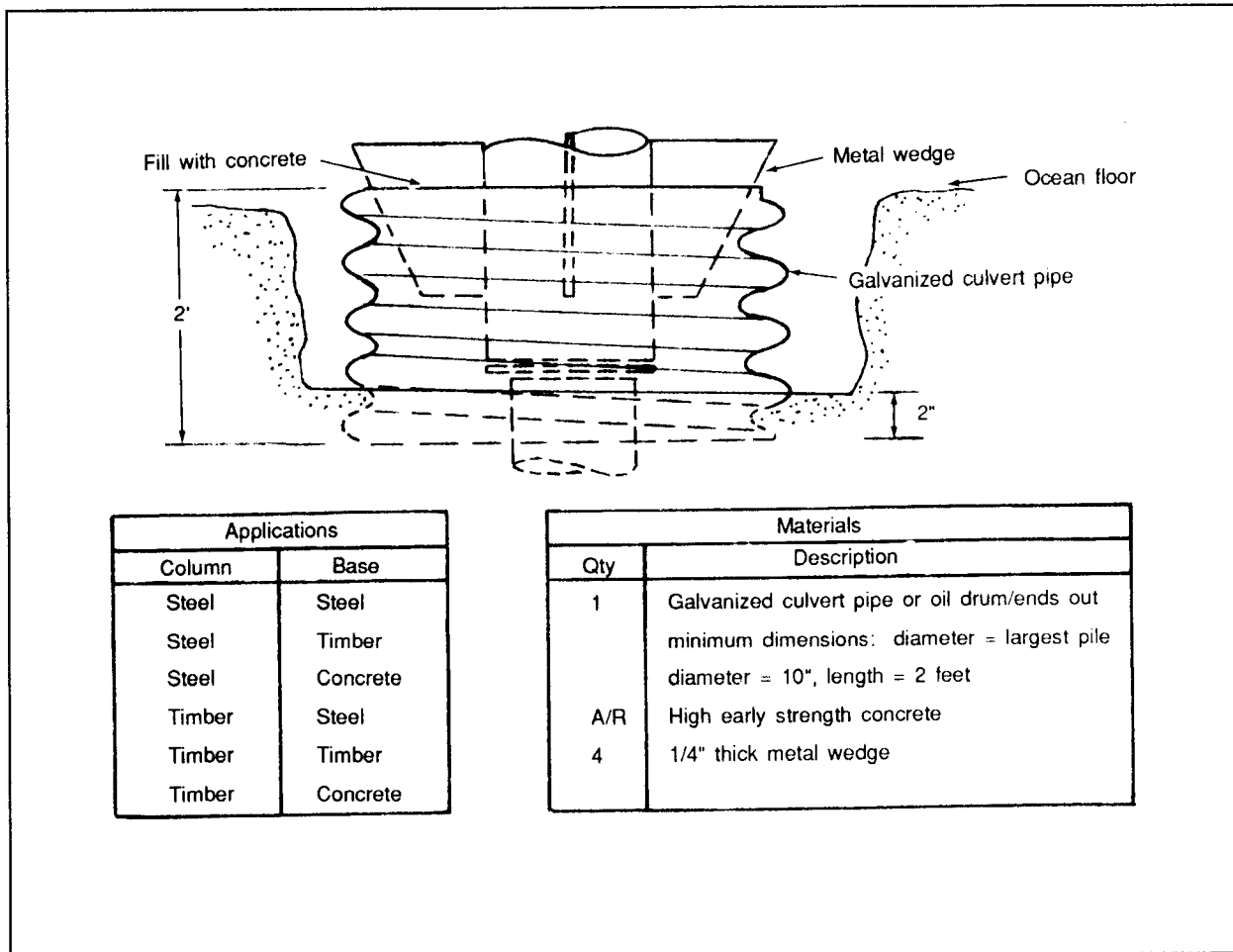

Figure A-26. Joining Steel Column to Base Pile, Column to Base Connections (Connecting Method 5)



Applications	
Column	Base
Steel	Steel
Steel	Timber
Steel	Concrete
Timber	Steel
Timber	Timber
Timber	Concrete

Materials	
Qty	Description
1	Galvanized culvert pipe or oil drum/ends out minimum dimensions: diameter = largest pile diameter = 10", length = 2 feet
A/R	High early strength concrete
4	1/4" thick metal wedge

Figure A-27. Joining Piles at the Ocean Floor with Concrete, Column to Base Connections (Connecting Method 6)

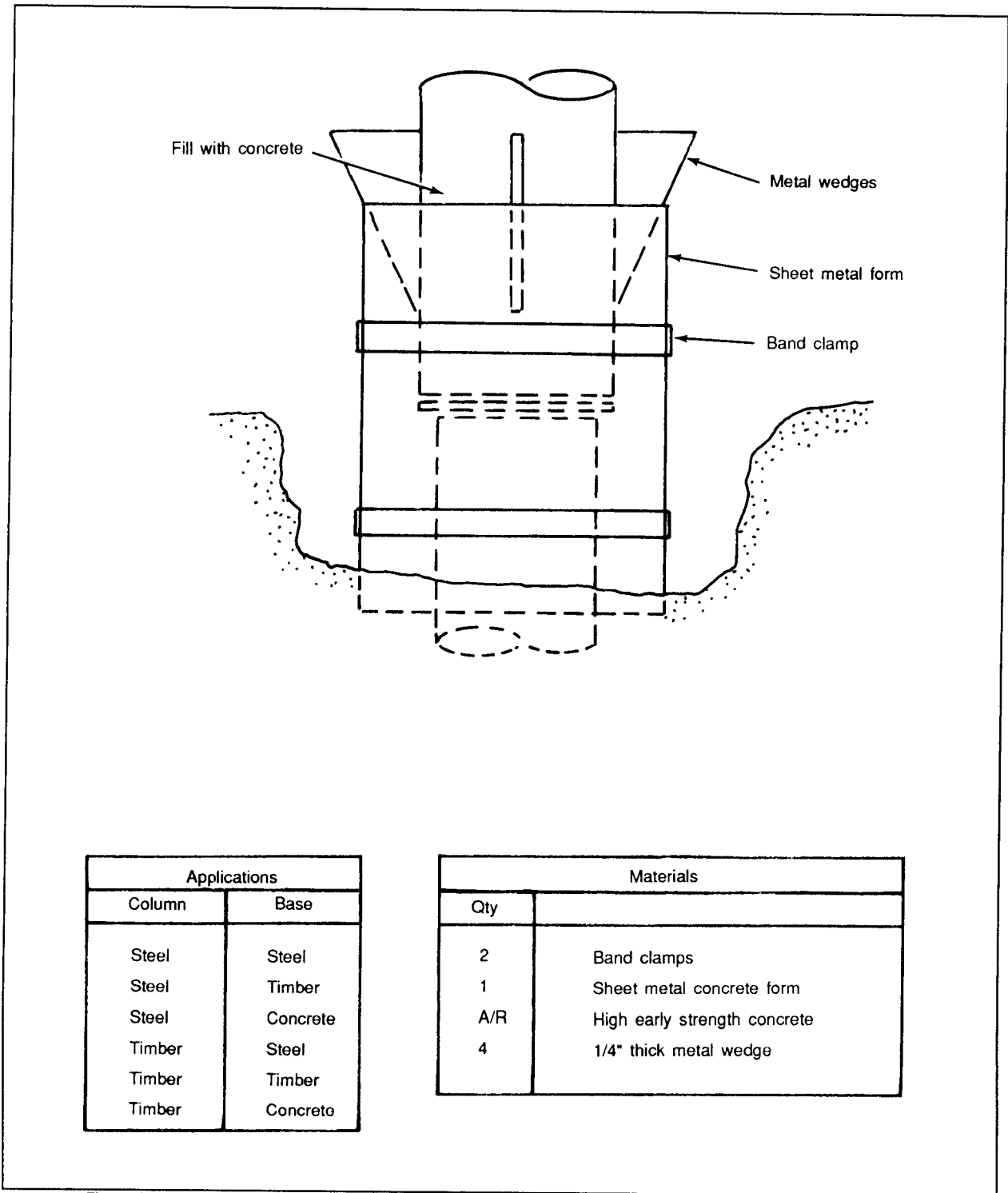

Figure A-28. Joining Piles at the Ocean Floor with Concrete, Column to Base Connections (Connecting Method 7)

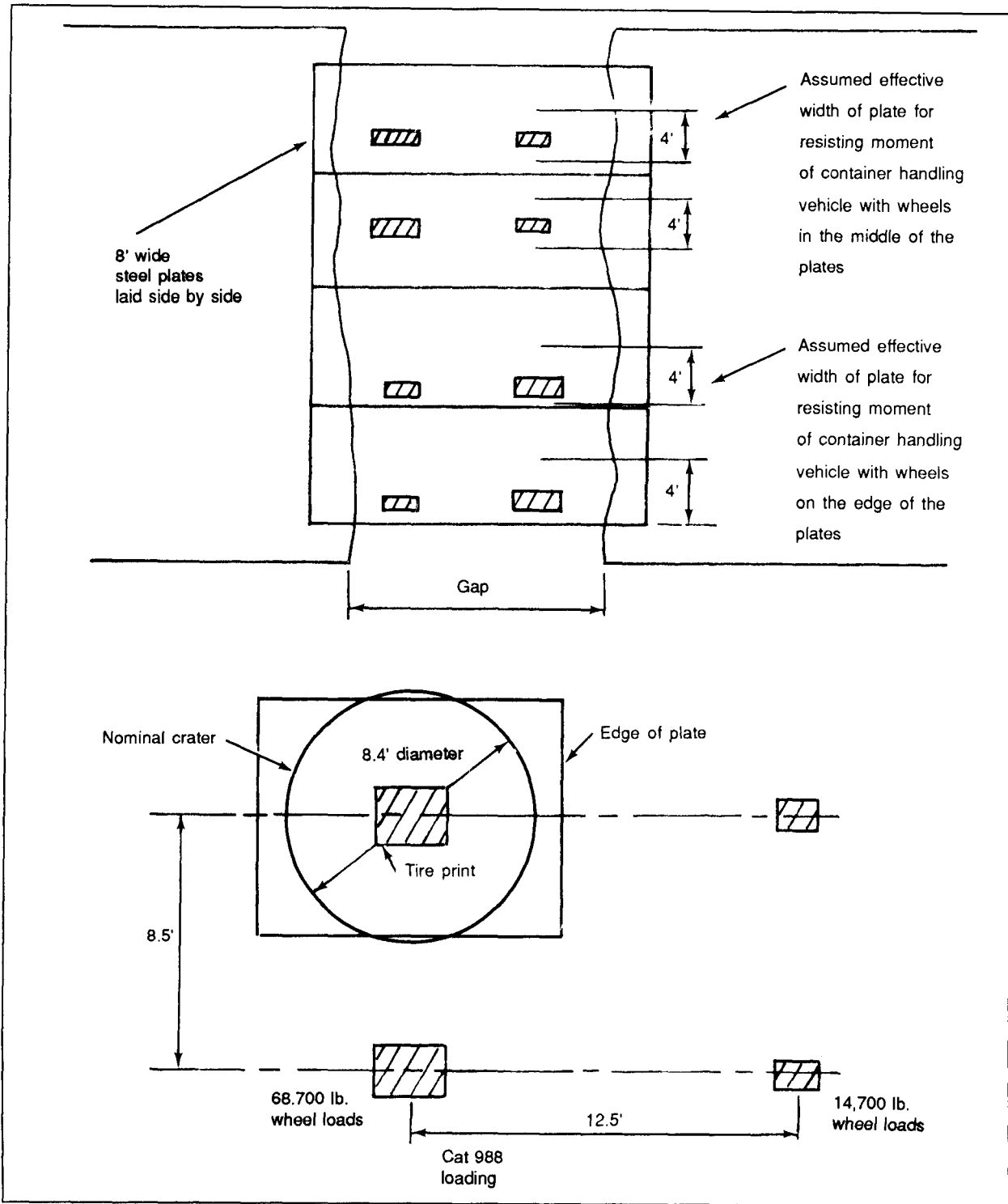

Figure A-29. Assumptions for Plate Repair Design

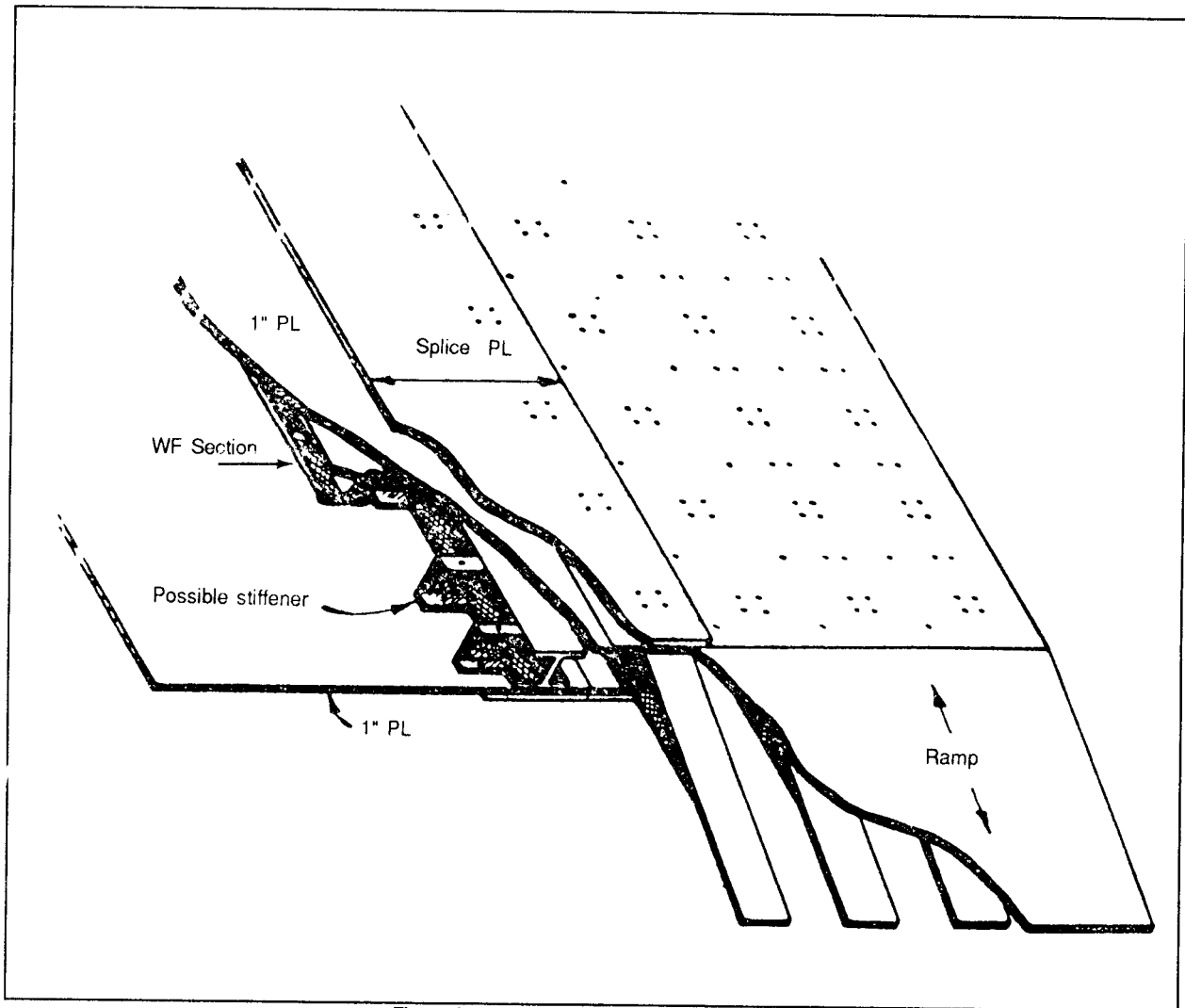

Figure A-30. Isometric View of Type A Module

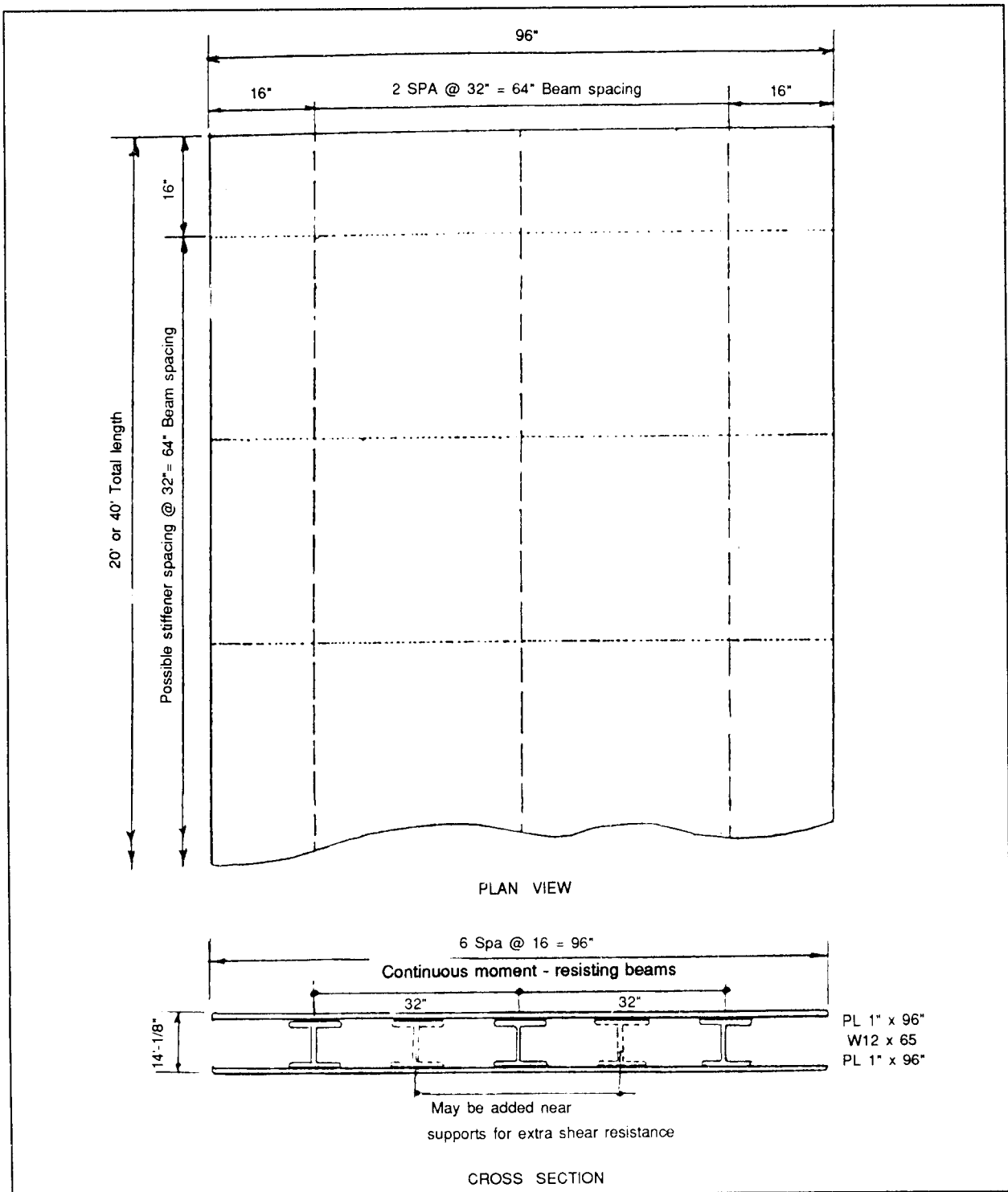

Figure A-31. Plan and Cross Section (Type A Repair Module)

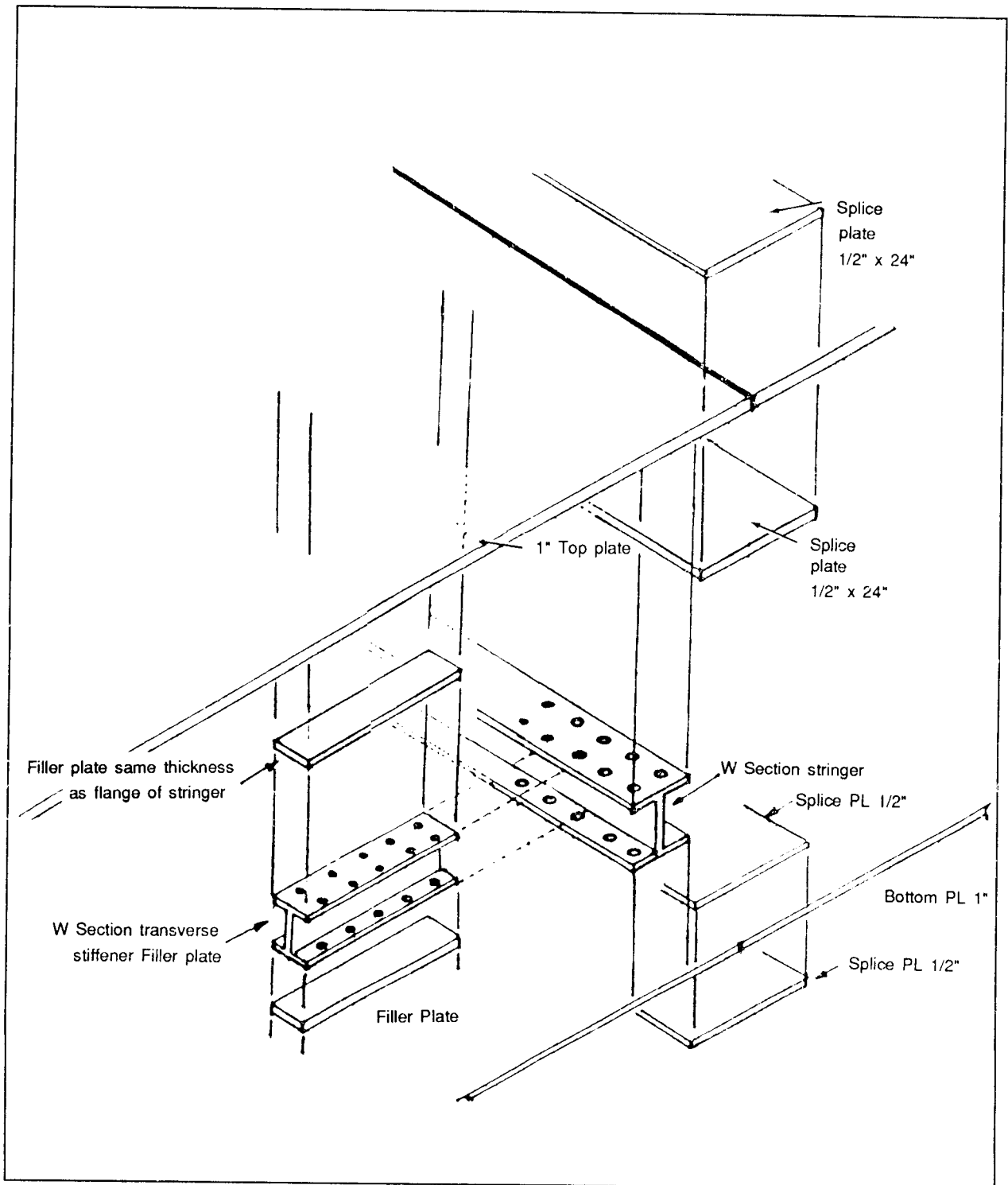

Figure A-32. Exploded Isometric View (Type A Repair Module)

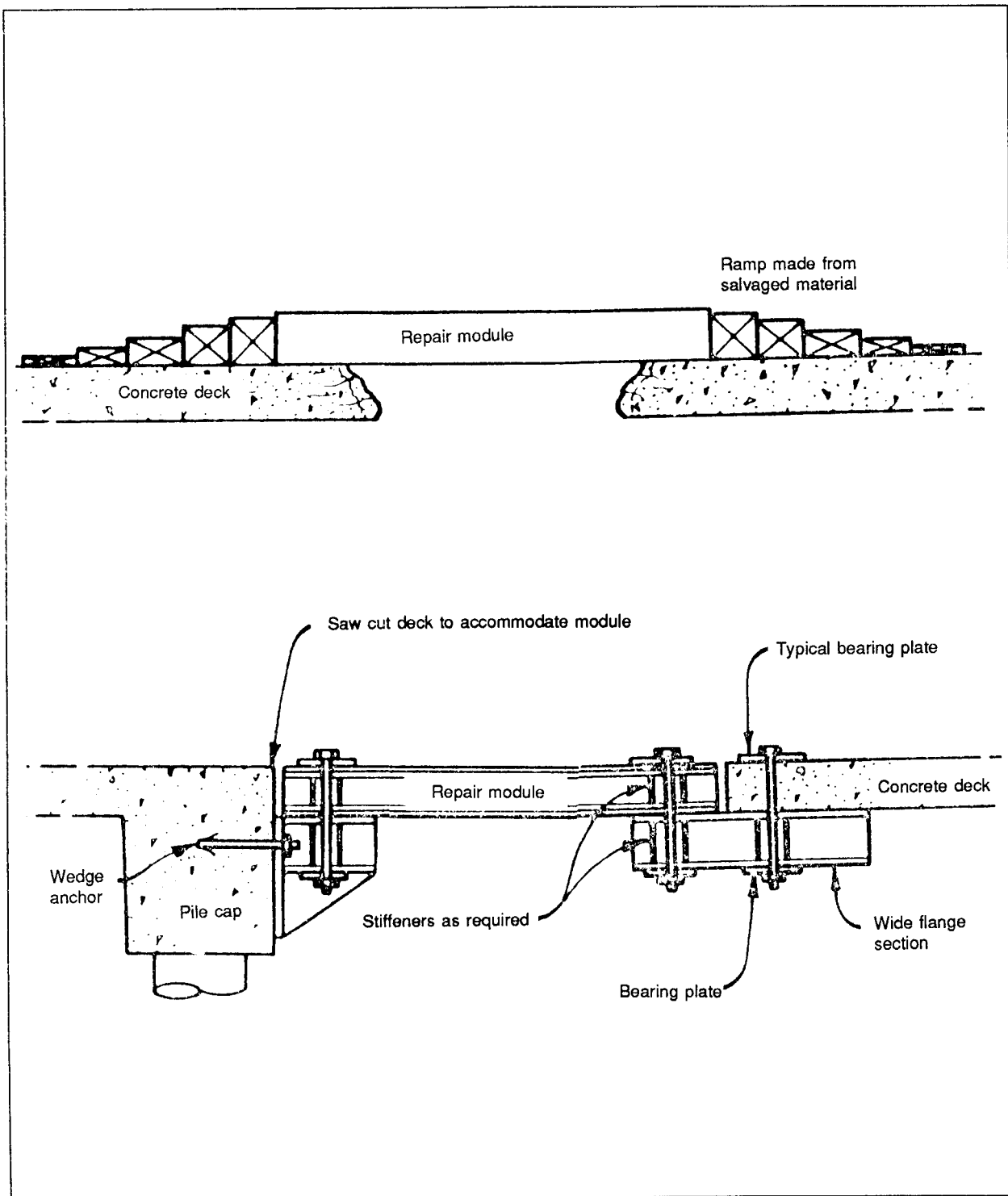

Figure A-33. Alternate Installation Methods for Repair Modules (Type A or B)

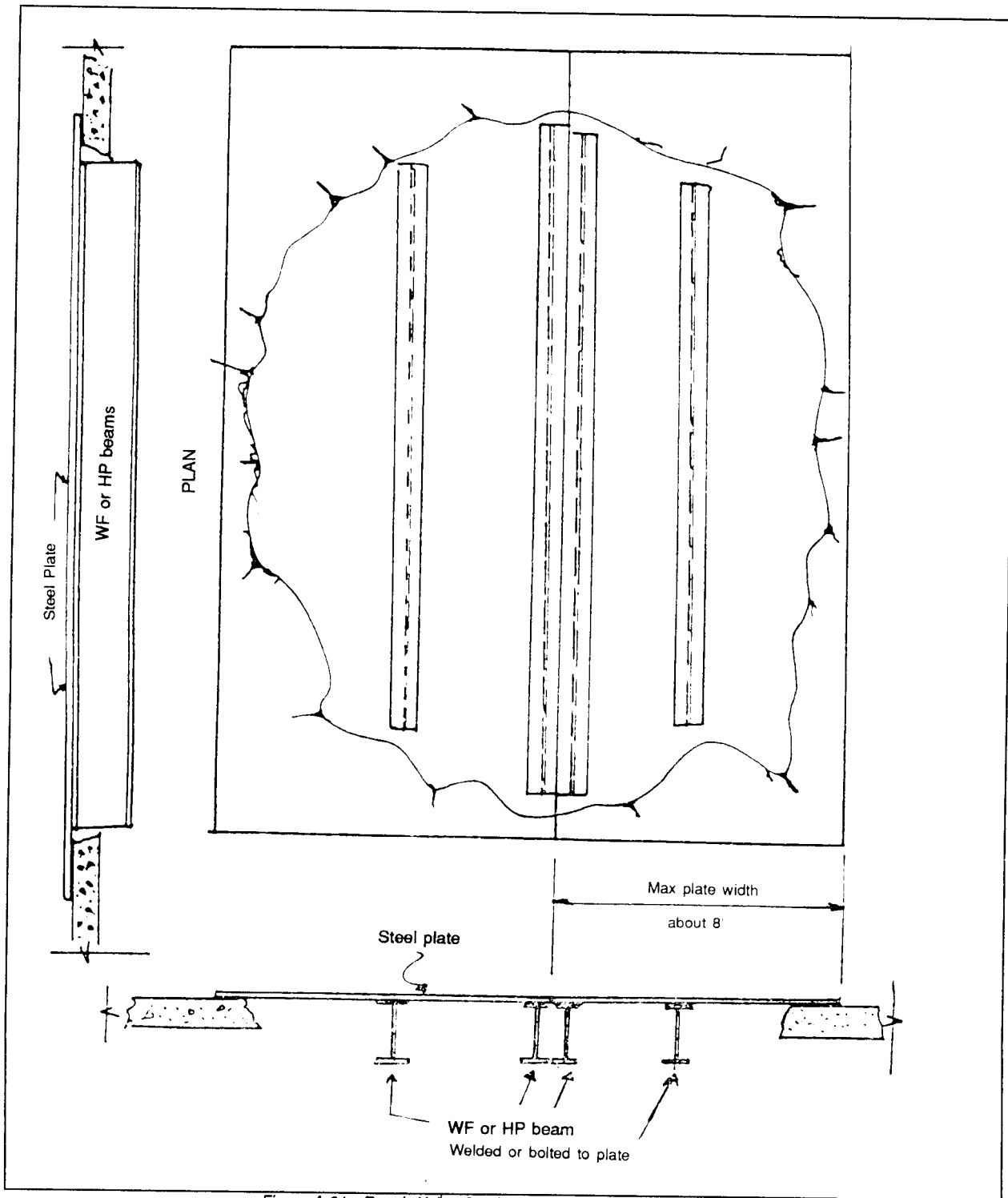

Figure A-34. Repair Using Steel Plate Reinforced by Steel Beams

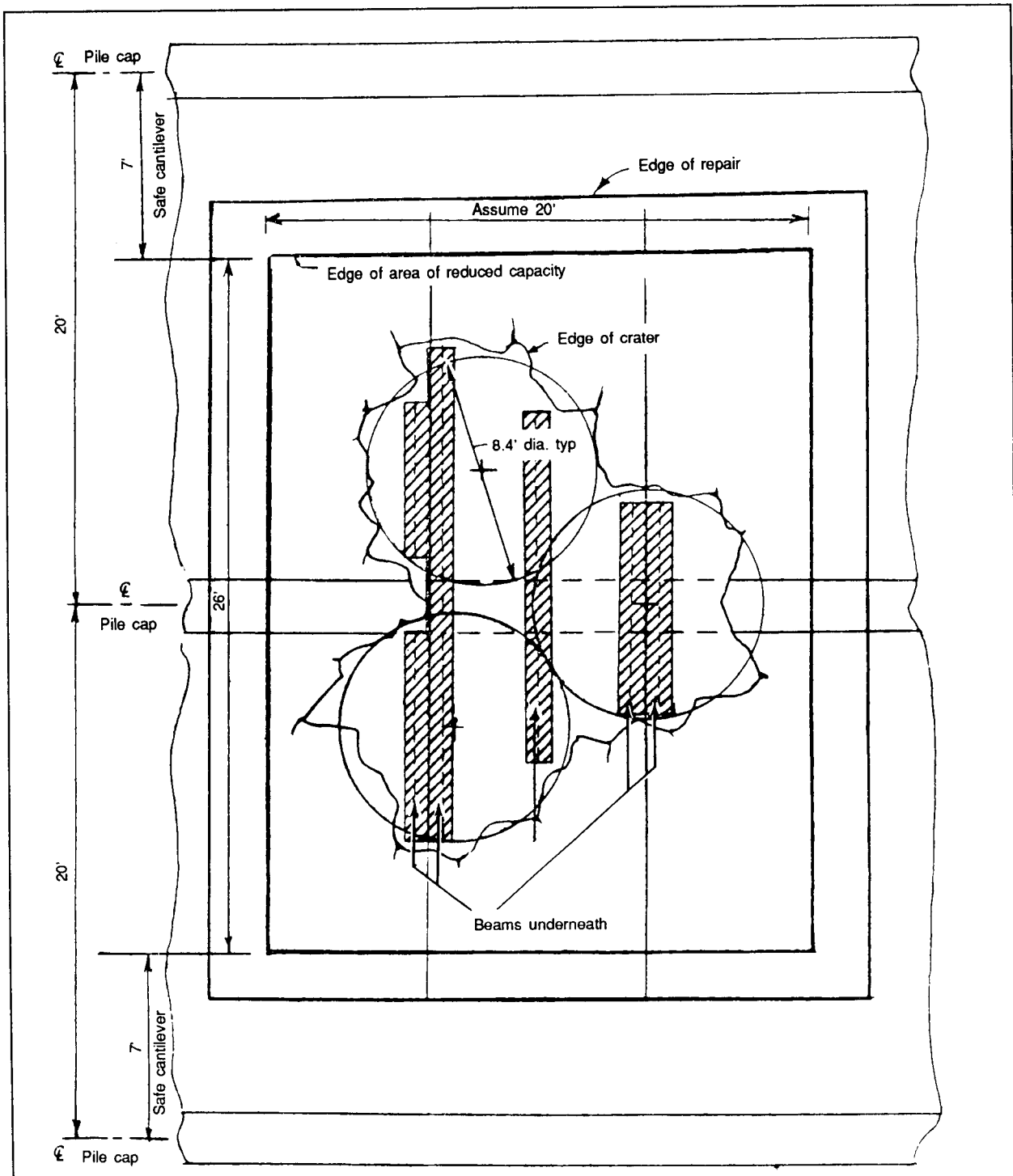

Figure A-35. Steel Plate Reinforced with Steel Beams (Repair for Case 3 Damage - 60 Foot of Steel Beam Required, Three 1-inch Thick, 8- by 30-foot Plates Required - Reinforced Plate Subconcept)

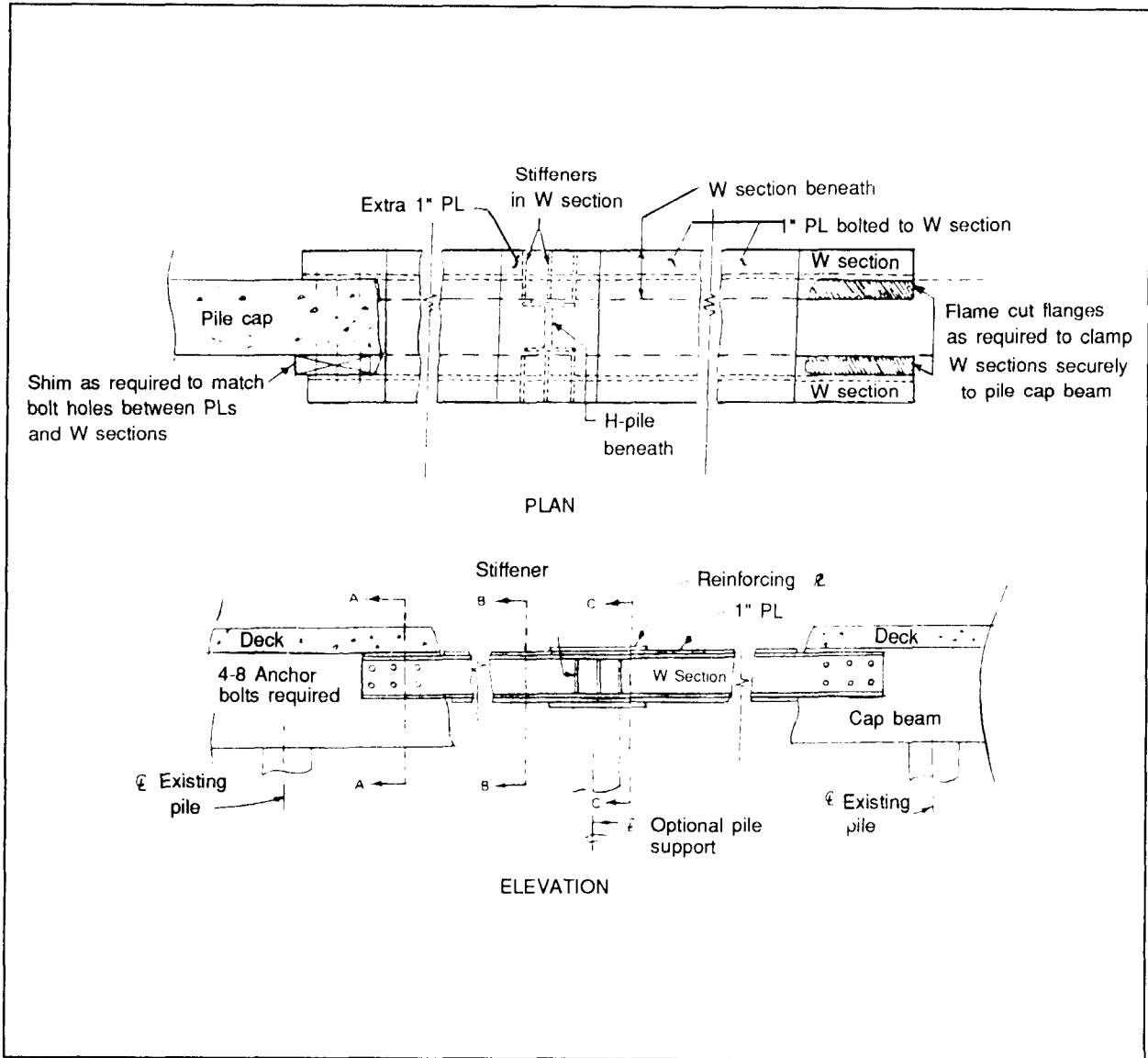

Figure A-36. Plan and Elevation Views of an Expedient Pile Cap

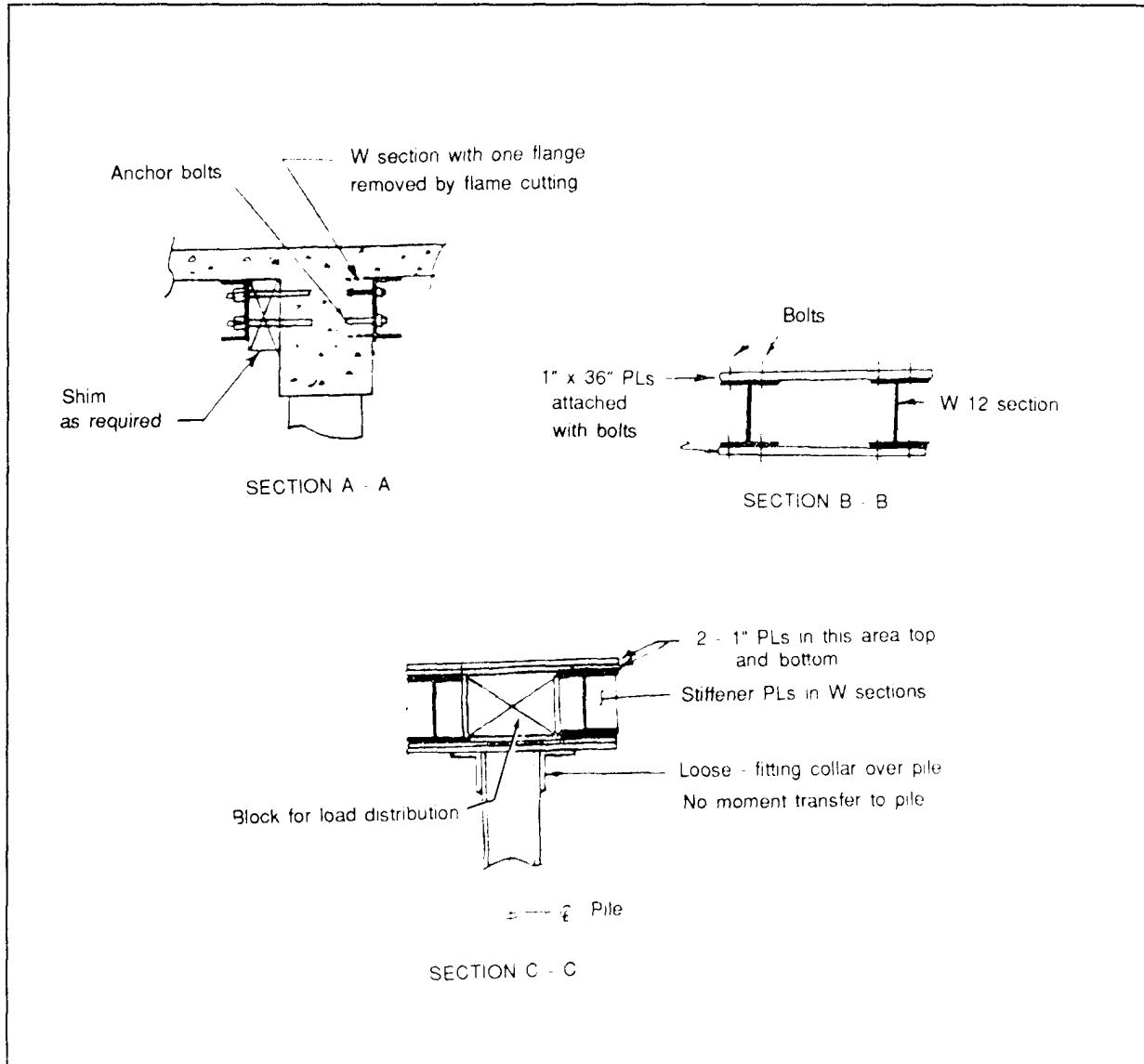

Figure A-37. Cross Sections of an Expedient Pile Cap

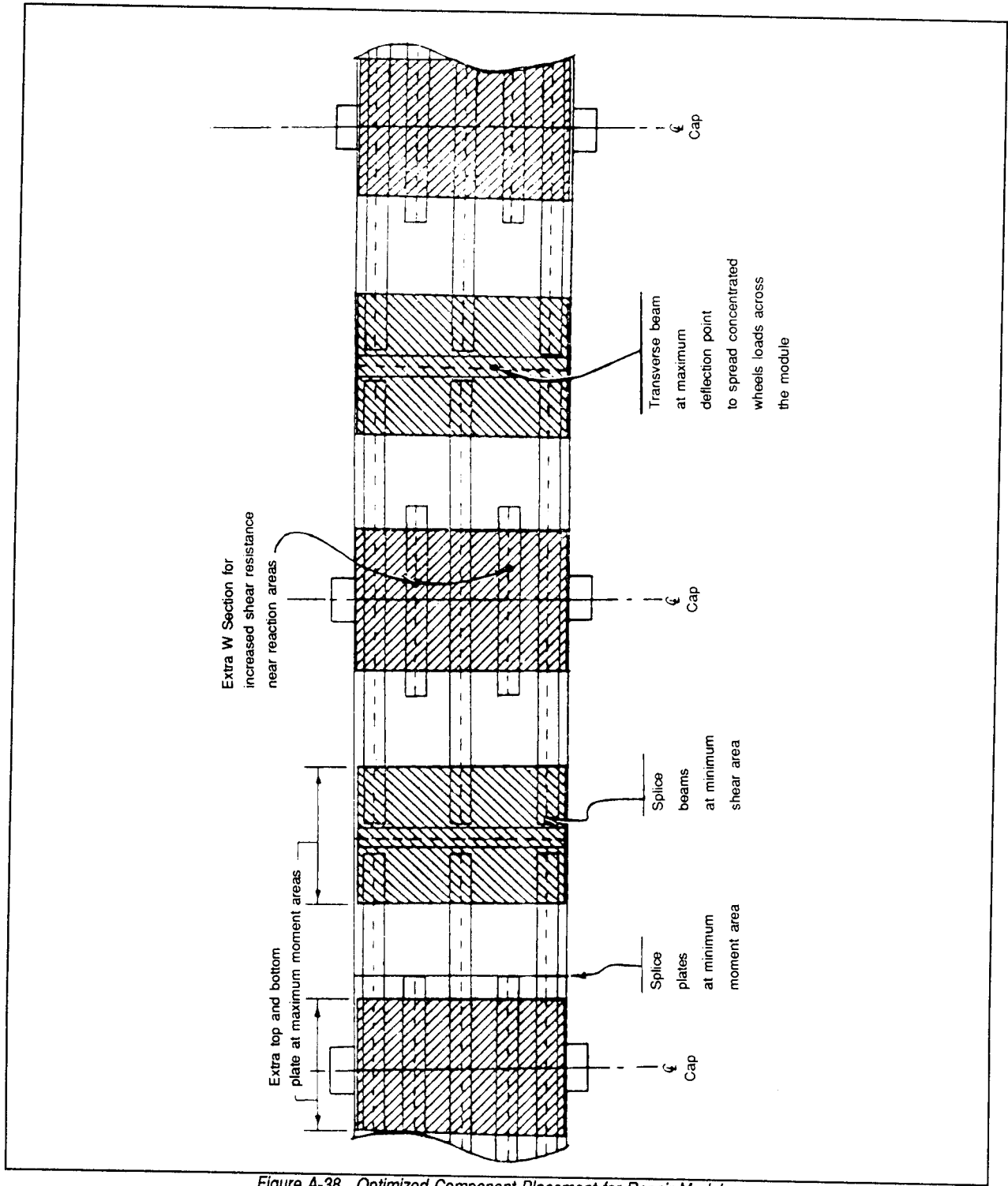

Figure A-38. Optimized Component Placement for Repair Modules

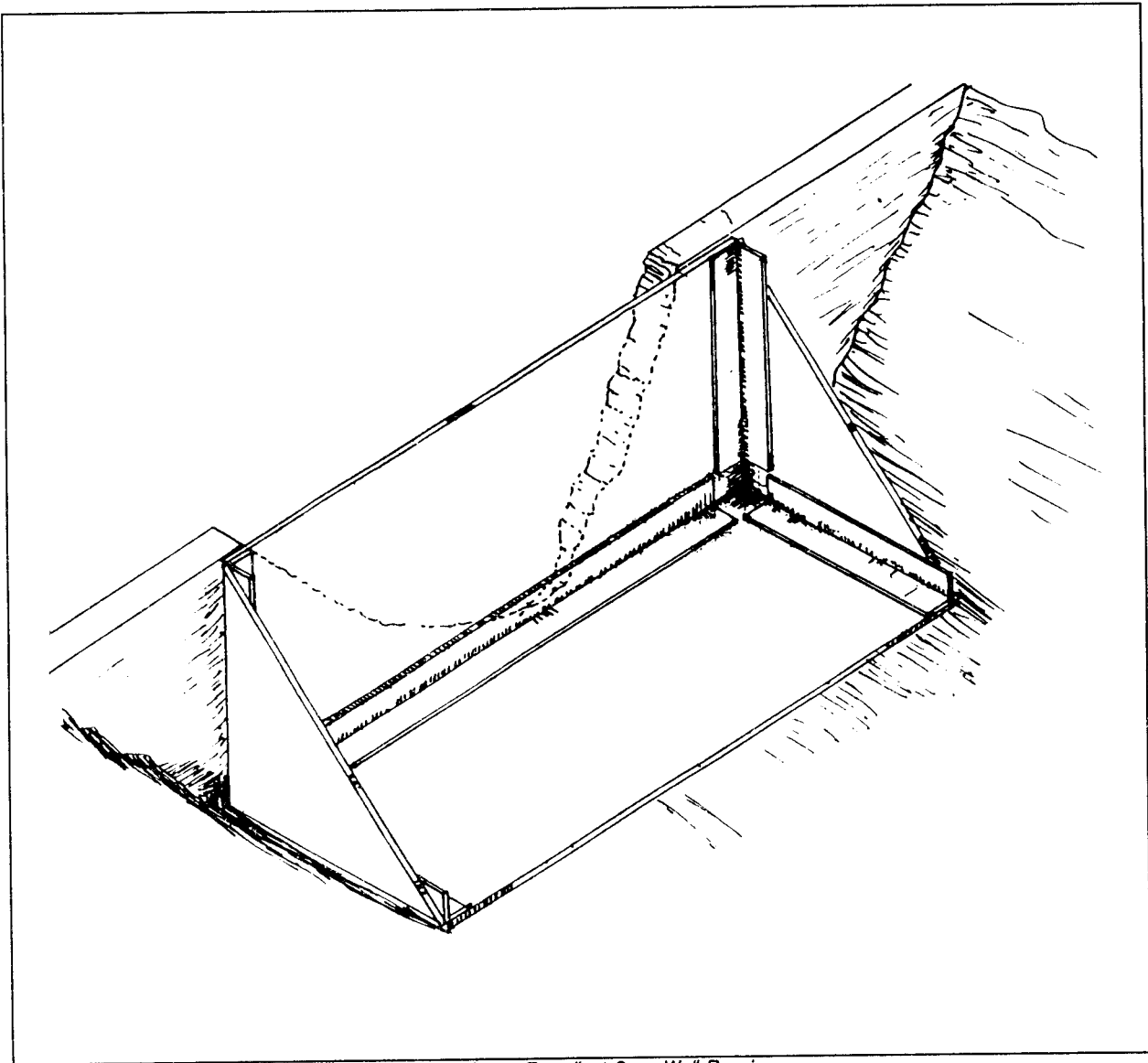

Figure A-39. Expedient Quay Wall Repair

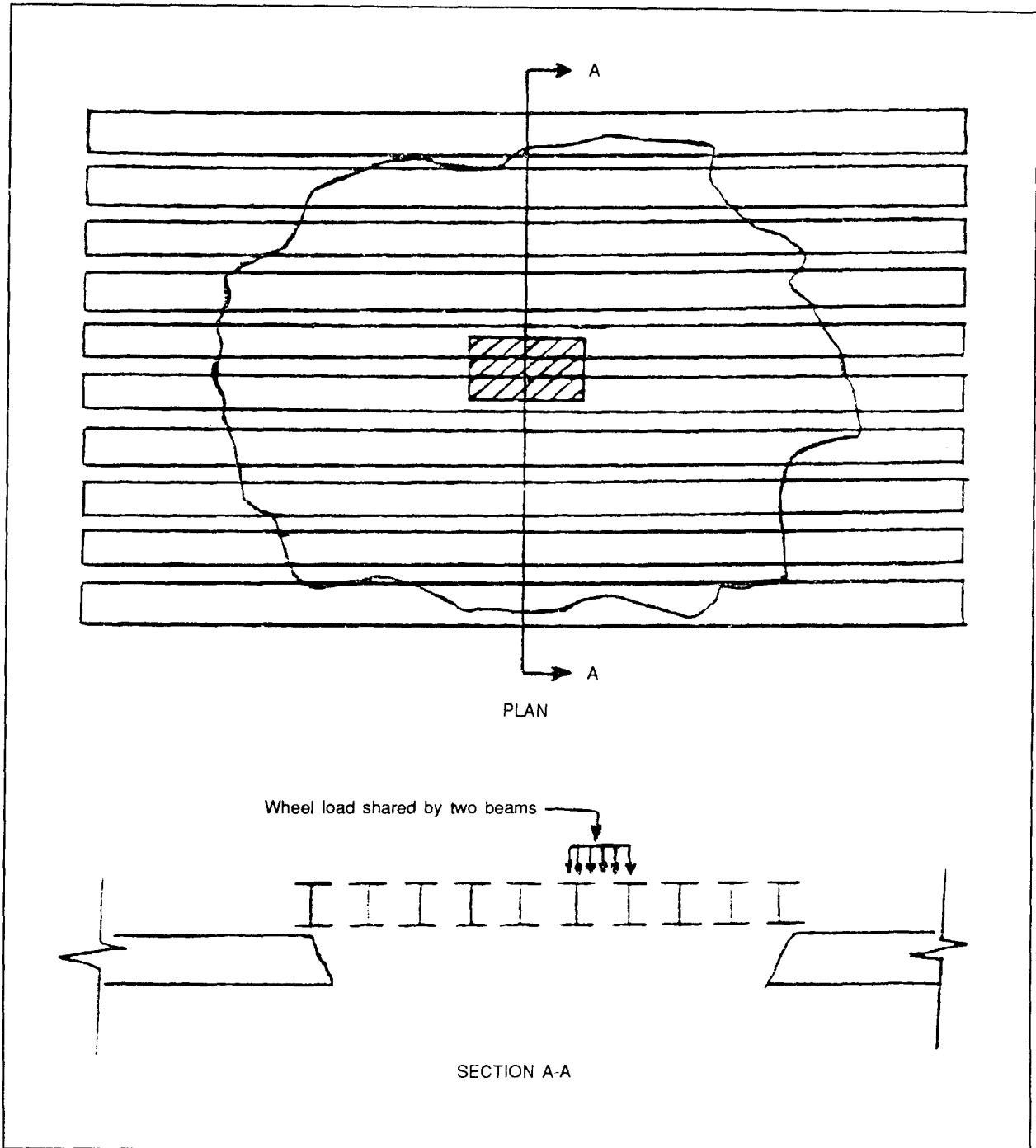

Figure A-40. Steel Beam Mat Concept Repair

APPENDIX B

DREDGING

PURPOSE

a. Dredging is the removal of earthen materials, including rock or coral, from under water. It increases the size of the waterway and provides construction materials for land-based projects. It also improves logistics. The wider, deeper shipping channel provides easier passage of vessels with deep draft. The deeper the draft of a vessel, the more tonnage it can carry. If few ships are available for logistics, then dredging can make these ships more efficient.

b. Material removed during dredging is often a naturally-occurring construction material. In military operations, natural materials make up for scarce resources. Typically, sand is available along the coast and in most rivers. Care must be taken to avoid clay or fine-grained sediments.

TYPES OF DREDGING

Two primary types of dredging occur: mechanical and hydraulic.

a. Mechanical equipment dredges easily with a clam shell, shovel, backhoe, or other device that scoops the material up. A simple type of mechanical dredge is a land crane, equipped with a suitable bucket mounted on a barge. This dredge needs barges or scows to move the material from the dredging site to the disposal site.

b. The hydraulic dredge uses water to remove and transport the material. This system has a pump for moving the water. The pump creates a vacuum or a pressure head, which moves water rapidly through the pipe. This system always has at least three components: dredging device, pump, and discharge system. There are many common hydraulic dredging systems--hopper dredges, sidecast dredges, cutterhead dredges, and dustpan dredges.

DREDGING OPERATIONS

a. The dredging site must be surveyed prior to planning the operation. Engineers need detailed topographic and hydrographic surveys and data on tidal range, tidal prism, flood stages, velocity, and other hydrographic characteristics, including the status of siltation and scour. They also need data on bridges, breakwaters, jetties, piers, islands, overhead and submarine cables, and type and size of vessels scheduled to use the waterway.

b. Engineers should dredge depths two to five feet deeper than the desired channel depth. This extra depth permits shoaling without restricting the draft of vessels using the channel. The extra depth also permits vessels to operate in waves caused by the movement of other vessels in the water. Moving up and down at the surface is also moving up and down in relation to the bottom of the channel.

c. The alignment and location of the navigation channel are important considerations in port development. The channel should parallel the current flow as closely as possible, and engineers should align the channel so that wave direction will be along the channel axis. Other refinements can reduce future maintenance dredging without affecting channel use. Because the dredging discussed here applies to the TO, long-term factors are not considered.

d. Curved channels are undesirable because vessels navigate by sighting on front and back ranges and by checking channel buoys. Navigation in a curved path is difficult. The channels should be laid out as a succession of tangents connected by short transition curves. Tangents should be as long as possible and curves should not exceed 30 degrees. If larger curves are required, then the channel should be widened at the curve to two or more times the normal channel width.

e. The disposal site should be located as close to the dredging site as possible. This practice will reduce the time and cost needed to complete the dredging job. The disposal site should be selected to minimize the possibility of the material being carried back into the navigation channels by natural or ship-generated currents. A disposal area should use the dredged materials as fill for a revetment or dike.

f. Ingestion of live ammunition is a major threat to dredges. Ammunition placed or accidentally lost in the waterway can explode when it passes through the pump, such accidents can disable or sink the dredge.

DREDGING RESOURCES

a. Dredging is considered part of construction. Therefore, the construction agent for the theater is responsible for it, including furnishing the equipment or contracts. In the past, dredging in theaters was done by a combination of host country equipment, contractors from the region, contractors from the United States, and US Government forces.

b. The US Army Corps of Engineers maintains CONUS ports and waterways using contractors and government-owned and operated equipment. It maintains a small fleet of dredges suitable for defense and emergency needs of the country. These are supplemented by a reserve fleet of contractor-owned dredges. Historically, the construction agent, when not the US Army, has sought assistance from the Corps of Engineers. The construction agent usually establishes an in-the-theater dredging office that furnishes dredge support to the theater.

c. The one reserve dredging unit currently in the US is in the Texas National Guard. A small federally owned and operated dredge fleet that is supplemented by the reserve fleet of privately owned and operated dredges is the best solution for future dredging requirements.

OBTAINING DREDGING SUPPORT

A step-by-step procedure for obtaining dredging resources (including technical assistance) in the TO follows:

a. Request assistance from the local construction agent in the theater.

b. If help is not available from the construction agent, the agent must request dredging support through channels.

c. Both the US Air Force and US Navy have some dredging resources. Use them if the construction agent makes them available. Remember, technical assistance is a resource that must be requested.

d. If all else fails, contact the Office of the Chief of Engineers, Washington, DC.

APPENDIX C DIVING

Section I. General

PURPOSE

a. Engineer divers support all diving missions in the theater of operations. Engineer support in the communication zone is provided on an area basis; and in the combat zone, it is provided on an individual task basis. Figure C-1 shows engineer diver deployment in the theater.

b. The Engineer Command (ENCOM) provides command and control to the theater army engineer force. Divers are assigned to the headquarters element of the ENCOM.

ENGINEER DIVING SUPPORT CONCEPTS

a. Engineer divers are deployed by the ENCOM based on mission priorities. Diver availability during mobilization is reduced because their numbers are limited in the theater. When diving assets are not used effectively, the ENCOM commander reassigns them to more critical mission sites.

b. Theater construction and repair missions that include divers are highly complex and require a management capability that spans interservice requirements and assets. To accomplish these missions, the theater commander sets construction priorities and policies. He also allocates construction assets and materials. The ENCOM commander applies these policies in assigning diving assets throughout the theater.

c. Combat Zone engineer diver tasks are usually in direct support of mobility operations. In the Communication Zone, the tasks usually center on sustainment operations, such as port construction, harbor clearance, salvage, and ship's husbandry. Divers also assist in interservice and immediate recovery operations.

d. The large mission requirements for engineer divers severely limits their availability during mobilization. Units are warned that divers are used mainly for Communication Zone construction and maintenance-oriented missions - not Combat Zone missions. Commanders with contingency plans that identify diver support requirements must consider the limited number of divers.

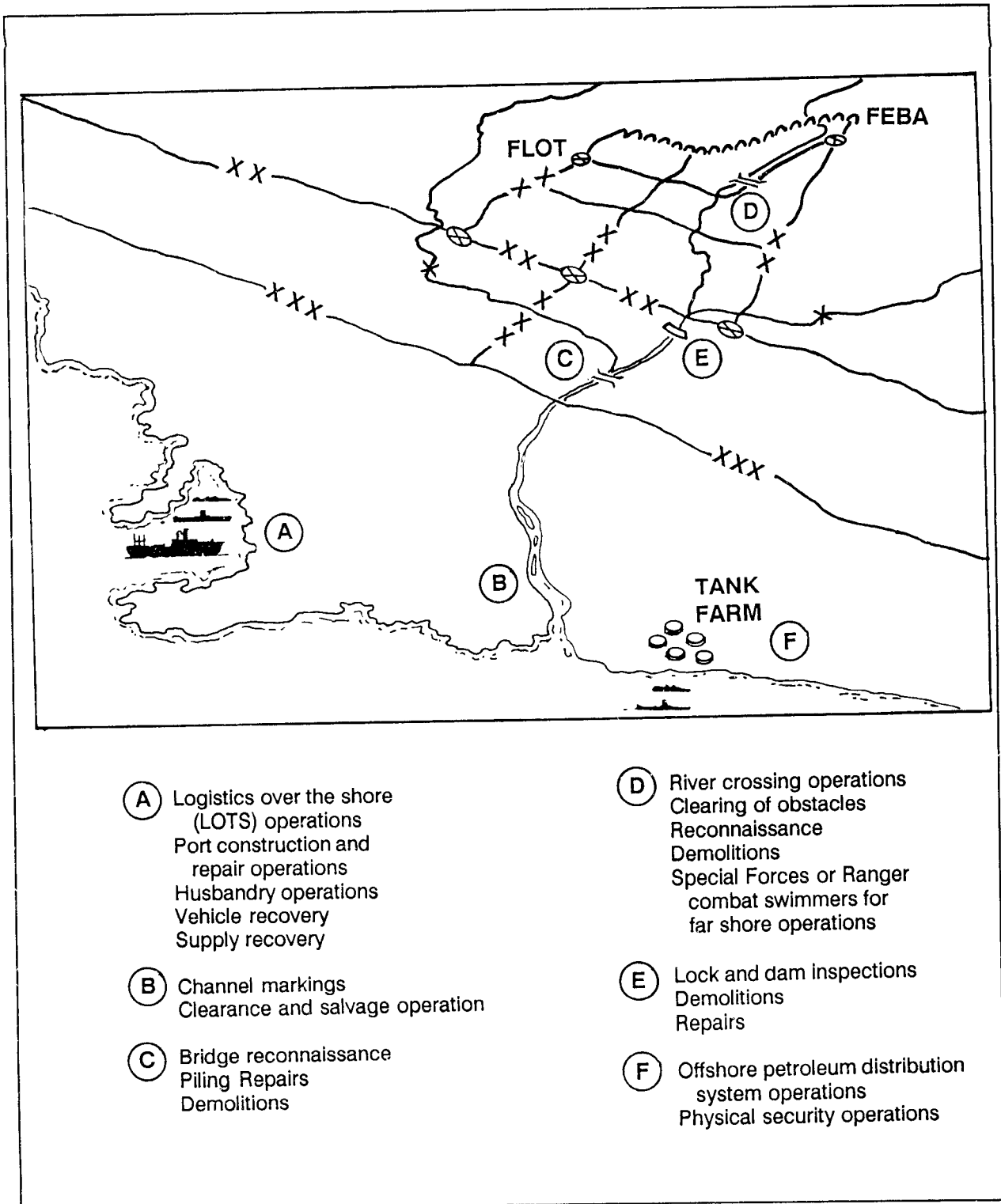

- (A)** Logistics over the shore (LOTS) operations
Port construction and repair operations
Husbandry operations
Vehicle recovery
Supply recovery
- (B)** Channel markings
Clearance and salvage operation
- (C)** Bridge reconnaissance
Piling Repairs
Demolitions
- (D)** River crossing operations
Clearing of obstacles
Reconnaissance
Demolitions
Special Forces or Ranger combat swimmers for far shore operations
- (E)** Lock and dam inspections
Demolitions
Repairs
- (F)** Offshore petroleum distribution system operations
Physical security operations

Figure C-1. Engineer Diver Deployment in the Theater

DIVING SUPPORT REQUEST PROCEDURES

The ENCOM commander allocates diving assets in the Communication and Combat Zones according to priorities established by the theater commander. After completing mission analysis, the ENCOM commander assigns divers to the appropriate organizational level. Figure C-2 illustrates request channels for engineer divers.

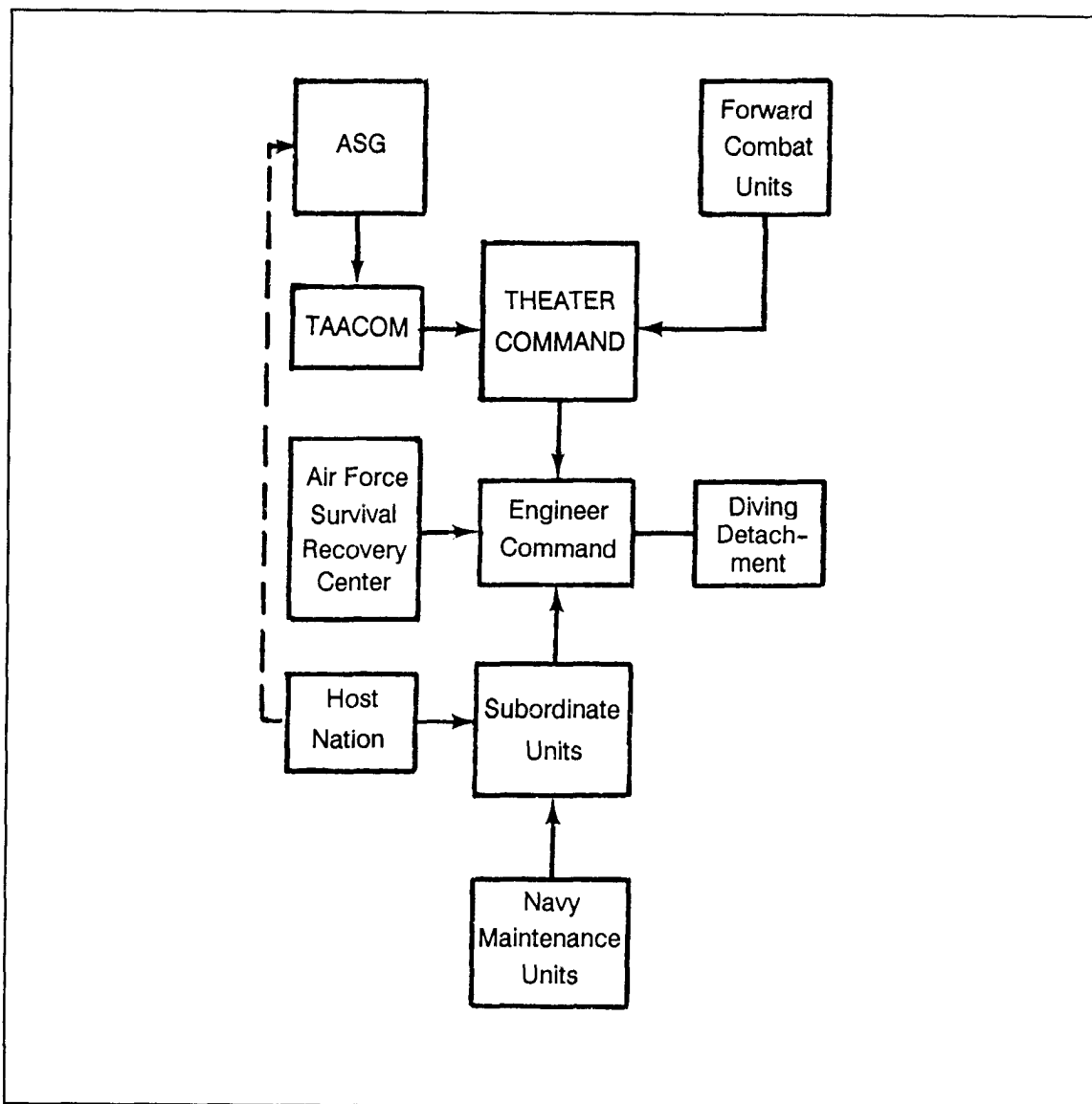

Figure C-2. Request Channels for Engineer Divers

COMMUNICATION ZONE

a. If an area support group (ASG) needs diving assets for underwater missions, it requests the diving support through normal channels to the theater command. The request must include mission details and an estimated time requirement for completion. If the request is approved, the theater commander will task the ENCOM to support the mission, and the ENCOM commander will assign diving assets. For short-term missions, diving assets are assigned in direct support through command channels to the ASG. For long-term or complex missions, divers are attached to a company- or battalion-sized unit.

b. For example, if a port construction company of an ASG needs diving assets for port repair, the ENCOM commander will assign the assets in an attached command relationship through command channels to the construction company.

Section II. Engineer Diving Force Organization

GENERAL

The engineer diving force is a relatively small and specialized organization. Each section of the diving force has specific duties and responsibilities, but is flexible enough to improvise in supporting the theater as the situation changes. The diving force is divided into two major groups:

a. The control and support diving detachment (C&S) provides command, control, and support of diving missions.

b. The lightweight diving team (LW team) executes most of the work performed by divers.

CONTROL AND SUPPORT DIVING TEAM

The C&S detachment provides command, control, liaison, and support functions for diving assets. Each C&S detachment supports as many as six LW teams. The C&S detachment has inspection and survey capabilities and provides the following specialized support to LW teams:

- a. Mission analysis for equipment requirements
- b. Training and diver requalification
- c. Special equipment and additional personnel to augment the LW section
- d. Diving equipment supply support and repair parts to the intermediate level
- e. Diving equipment intermediate level maintenance
- f. Recompression chamber treatment
- g. Specialized medical support

LIGHT WEIGHT DIVING TEAM

a. The LW diving team is assigned to a C&S detachment and is dependent upon it for specialized support. The LW units are allocated based on mission requirements. The teams are usually attached to company-sized units if the mission requires extended diver support. The supported units usually are: engineer company, port construction; transportation company, floating craft, general maintenance; and quartermaster company, marine pipeline terminal.

b. Capabilities:

* The LW team has 17 soldiers and sufficient equipment resources to deploy either one surface-supplied diving team or two scuba sections.

* The LW team performs diving missions to 190 feet with a 2.5 knot (4.2 feet per second) water current. They perform scuba missions to a depth of 130 feet with 1 knot (1.7 feet per second) water current. The LW team cannot support 24-hour operations or work in conditions requiring total diver enclosure for protection. The usual work shift for the LW team is 12 hours. For 24-hour operations, the LW unit needs extra personnel, support, and equipment from the C&S detachment.

Section III. Diving Missions

a. Engineer divers require time to move, set up, and begin operations. Once on site, a diving section may need up to two hours of preparation time. It is critical to include diving planners from the C&S detachment during the early planning stages of an operation to ensure successful diving missions.

b. Lightweight diving teams provide underwater construction support for the following operations:

- * Port construction and repair
- * Clearance and salvage (See Section IV)
- * Ship's husbandry
- * Physical security
- * Logistics over the shore (LOTS)
- * Offshore petroleum distribution systems
- * River crossing
- * Graves registration
- * Pre-occupation activities
- * Pre-occupation activities in support of port construction

c. Rehabilitation missions include:

- * Initial underwater surveys to determine the possibility of restoring port facilities to operational status
- * Inspection of damaged, sunken vessels or other obstructions in port to determine salvage or removal requirements
- * Development of salvage plans for clearing the port area and ship's channels
- * Development of a diving and salvage effort time analysis for port restoration
- * Underwater damage assessment of existing pier facilities

d. The diving detachment commander provides a detailed report describing existing damage and recommendations for repair to the Army water terminal commander, the area engineer, and the port construction company commander. The report includes-

- * Port restoration plans
- * Sunken vessel location
- * Ship's channel obstacles
- * Vessel damage
- * Vessel or obstacle removal techniques
- * Underwater mines and munitions location

NOTE: Engineer divers are not capable of explosive ordnance disposal (EOD) missions. The report must include a basic description of mines or munitions and their locations for later removal by qualified personnel.

OCCUPATION ACTIVITIES

Occupation activities are conducted to clear and repair ports and harbors. Divers provide hydrographic data and port charts to the Army water terminal commander, port construction units, and area engineer. Divers also provide ongoing quality assurance inspections of underwater construction activities. Occupation activities include:

- * Port construction
- * Port repair
- * Clearance operations
- * Salvage operations
- * Underwater physical security
- * Graves registration support

PORT CONSTRUCTION

a. Building new ports and port facilities is a major undertaking that usually requires extensive diver support. Support requirements include the initial port site reconnaissance and selection. Divers perform a hydrographic survey of the proposed area to determine possible locations for ship channels, deep water mooring sites, and underwater obstacles.

b. Hydrographic surveys provide the port commander with a detailed chart of underwater port areas. The chart indicates the depth gradients, ship channels, and location and type of obstructions in the operational area.

c. Additional port construction operations include clearing obstacles or obstructions, vessel or equipment salvage, and installation of underwater security systems.

PHYSICAL SECURITY OPERATIONS

a. Physical security operations include the development of active and passive security systems to protect or provide early warning of impending danger to ports, ship channels, or pier facilities.

b. Divers can assist in placing permanent physical security systems in port areas, on freed bridges, and in waterway lock and dam systems. Divers also perform pre-entry security swims for vessels moored outside the secured boundaries of a port, security system, or maintenance operation. The request for diving support must include the type of physical security system used.

c. Physical security systems are usually placed at harbor entrances, along the open areas of port facilities, and around bridge abutments. The systems are passive or active and are designed to stop or detect vessels, underwater swimmers, or floating mines. The systems usually require diving support to install and maintain them.

d. Passive security systems require introducing obstacles or barriers that restrict the approaches and entrance to a harbor. Barriers across a harbor's access channel usually require constant maintenance and repair by divers. Electronic security systems are designed to detect or deter attack by underwater swimmers. Divers place and secure underwater systems after qualified personnel assemble them on shore.

e. Security swims are another form of physical security. Divers can perform physical security swims on the underwater portion of any vessel moored outside the secured perimeter of a port facility.

PORT REPAIR

a. The repair of existing port facilities includes piers, quays, wharfs, dry dock facilities, marine railway systems, and other port structures. The method used depends on the original construction material, type of repair material available, and degree of repair desired. To ensure timely procurement of needed materials, divers must make a detailed underwater reconnaissance and assist in developing the bill of materials for repair.

b. Divers perform underwater repair of bearing piles, fender systems, and dolphin systems. Timber structure repairs range from replacing wood components to inserting steel members and applying concrete protective jackets.

c. Concrete is used to repair many port structures. These repairs require divers to clean the area with specialized equipment. Tasks range from filling minor cracks to replacing supporting steel structures. Usually, divers must place underwater concrete forms as well as the actual concrete.

d. Steel is used to repair bearing piles, piers, and fender systems with rubber bumpers. Steel structure repair is complex and requires divers to:

- * Clean the repair area using specialized equipment
- * Repair minor cracks using underwater welding techniques
- * Remove and replace a damaged component
- * Place underwater concrete forms and concrete

GRAVES REGISTRATION

Divers assist in the recovery of personnel drowned during water operations. Their support is limited to the underwater search and recovery of bodies and not the recovery of bodies found floating or along the shoreline.

Section IV. Clearance and Salvage Operations

GENERAL

a. Clearance and salvage operations include removing and recovering usable material from ports and navigable waterways to reopen them for operations. The operations include:

- * Recovery of equipment and supplies
- * Removal of small obstacles
- * Salvage of small ships or aircraft

b. Diver support depends on:

- * Amount and size of obstructing debris
- * Number of diving teams available
- * Additional equipment and vessel support needed. Early planning which includes divers is important to allocate assets successfully

CLEARANCE OPERATIONS

a. The purpose of clearance operations is to neutralize all obstacles blocking the channels in the port, docking facilities, mooring sites, marine railways, dry dock facilities, and lock and dam structures. These are usually natural obstacles (underwater rock formations), battle debris, or enemy-emplaced objects designed to prevent timely use of the facility by occupying forces. Clearing of salvageable vessels is discussed in the Salvage Operations section, page C-8.

b. Various methods are used to remove obstructions within the port area. Methods include using lifting bags from a diving tool kit, demolition charges, cranes, and underwater cutting equipment. Additional lifting force can be obtained from various items commonly found in a port facility, such as empty 55-gallon drums.

c. The use of demolitions underwater is an efficient method for removing obstacles in the port area. Special precautions, however, are required in the employment of demolitions in an underwater environment. Use electric firing systems whenever possible. This firing system improves control of the detonation of the charge, thus increasing the diver's safety. Verify the safe distance requirements for equipment and personnel in the water. Charges detonated in close proximity to vessels or personnel in the water can cause substantial damage or injury.

d. Underwater cutting operations are often required to reduce obstacles to a manageable size prior to removal. Divers have specific equipment for performing underwater clearance operations. The equipment includes the following hydraulic power, electric power, and common hand tools:

- * The hydraulic power package includes the tools necessary to cut, drill, and clean structural components during construction or clearing operations. It also contains flexible lifting bags.

- * The electric cutting and welding package includes the equipment necessary to perform underwater cutting and welding operations.

- * Common hand tools are used underwater if the powered sets are not available. Time needed to perform tasks underwater by hand greatly increases mission time due to the difficulty of working underwater.

e. The nature of unloading and transporting supplies at sea usually results in the loss of some supplies into the water. Divers can recover these supplies quickly, assuring continued support to fielded units.

SALVAGE OPERATIONS

a. Major salvage operations usually include clearing and removing vessels blocking port channels, berthing and docking facilities, mooring sites, and lock and dam facilities. The ability of divers to clear these vessels depends on the type, size, and location of the damaged vessel, and the time available for the salvage effort. Methods of vessel salvage range from simple hole patching and dewatering to the complete dismantling of the vessel into sections for removal.

b. Vessels that are beached arresting on the bottom with the superstructure above the mean low watermark are salvaged by patching exterior holes and dewatering the hull. The vessels are then towed to another location for repair by qualified units.

c. Vessels which are sunk with the superstructure below the mean low water level require more extensive salvage operations. Divers must make the entire vessel watertight. The vessel is then lifted by dewatering, attaching underwater lifting devices, attaching lifting devices from surface cranes, or by a combination of these techniques.

d. Unsalvageable vessels are either left in place, sectioned and removed, or flattened with demolitions. Sectioning includes cutting the vessel into manageable pieces, then removing the pieces to designated locations. Flattening includes removing the superstructure and crushing the hull into the port bottom using demolitions.

Section V. Logistics

GENERAL

Engineer divers must have logistical support to perform their wartime missions. Commanders must understand the combat support and combat service support system and know where to request the correct logistical support to ensure successful diving missions. Diving support requirements sometimes are quite substantial, and limitations can totally change a carefully made plan.

COMBAT SUPPORT

Divers depend on supported units for combat support and survivability needs, including:

- * Enemy air attack suppression
- * Enemy indirect fire suppression
- * Scatterable and fixed mine clearing
- * Underwater mine clearing
- * Nuclear, biological, chemical (NBC) decontamination
- * Ammunition
- * Survivability position construction

COMBAT SERVICE SUPPORT

a. Divers depend on supported units for most combat service support needs in the areas of:

- * Maintenance

- * Supply
- * Administration

b. The C&S detachment provides diving teams with intermediate direct and general support maintenance on all life support systems and diving equipment. The C&S detachment and LW diving teams depend on supported units for all Class IX supplies (repair parts) and maintenance support above the operator level for ordnance equipment. Supported units, not serviced by a direct support company, order ordnance repair parts from the ASG maintenance battalion. Repair parts for diving life support systems and diving equipment are ordered by the C&S detachment directly from the ENCOM.

EQUIPMENT SUPPORT

a. The supported unit commander has the ultimate responsibility to allocate local assets and assign local work priorities to divers. Equipment common to most diving missions includes:

- * A floating work platform to provide surface-supplied diving capabilities away from the shoreline. The platform needs enough space to accommodate diving systems, support equipment, and required personnel.

- * A crane to lift diving equipment onto the diving platform. It is also used to lift special equipment from the water for maintenance operations or to remove items during clearance and salvage operations.

- * Generator and welder sets for underwater welding operations.

- * An acetylene torch set for metal cutting and salvage operations. Divers cannot perform welding on aluminum alloys.

b. Some diving missions require special equipment and support from the units dedicated to the construction and repair of port facilities. The missions and special equipment include:

- * Port construction and repair operations. The support requirements for divers are usually available from port construction companies. Special equipment includes concrete mixing machines, concrete pumps, pile drivers, piles, clamshell digging devices, and construction machinery.

- * Clearance and salvage operations. Special equipment includes large winching devices or crawler tractors, such as D-7 dozers, to assist in pulling small craft or debris from ship channels. Extra work platforms and warping craft are sometimes needed.

- * Physical security operations. The construction of physical security systems requires various types of support, depending on the type of security system installed. Special equipment includes watermarkers for underwater mines, electronic security devices, netting, and control craft.

c. The special equipment needed for support requirements usually takes extra time to procure or fabricate. Early planning and coordination help reduce logistics problems during diving missions.

Section VI. Limitations

ENVIRONMENTAL

a. Each type of diving has environmental limitations to consider when planning and conducting a diving operation. The C&S detachment should provide a survey team to study the work site and make recommendations regarding the use of divers. Factors such as water temperature, depths, currents, and environmental protection must be considered. The following table lists average underwater limitations.

b. If water speeds are in excess of the limits in the table, some alternatives are possible to rectify the problem. Moving the operation site to slower waters or constructing baffles to deflect the water are two examples. Sometimes cofferdams, piles, or jetties can be used to isolate a construction area to improve working conditions.

OPERATIONAL

a. Divers do not have the capability to work in unsecured areas. The supported unit must provide all site security during diving operations, especially in the combat zone. If explosives or mines are found during a diving mission, divers only mark and report them for removal later by qualified EOD personnel.

b. During river crossing operations, divers should not be assigned lifesaving responsibilities because they are not trained or qualified as lifeguards. Divers can perform underwater recovery operations but not to the time limits needed for emergency rescue operations. Diving skills are not recognized as a substitute for lifesaving skills. Properly equipped soldiers who are qualified by the Red Cross or similar agencies should perform lifeguard duties.

Table C-1. Diving Limitations

Type	Normal Water Depth (ft)	Water Current (knots) (fps)	Duration Under Water* (min)	NBC Protection	Environmental Protection	Salt Water Temperature Minimum (F°)
Heavyweight	190	2.5 4.2	40	None	Maximum	32
Lightweight	190	2.5 4.2	40	None	Minimum	0
Scuba	130	1.0 1.7	10	None	None	0

*Also limited by individual diver endurance.

GLOSSARY

AASHTO American Association of State Highway and Transportation Officials

ACofS Assistant Chief of Staff

AFCS Army Facilities Components System

AR Army Regulation

ASTM American Society for Testing and Materials

Army water terminal Army controlled harbor or port facilities

azimuth lateral deviation of a projectile

balk beam or rafter

batten narrow strip of wood

batter slope, as of an outer side of a wall, that recedes from top to bottom

batter pile pile driven at an angle for lateral support as fenders or part of a dolphin

beam maximum width of a vessel's hull

bearing pile pile carrying a superimposed load, which it transmits to the ground

bending moment algebraic sum of all moments located between a cross section and one end of a structural member. A bending moment that bends the beam convex downward is positive and one that bends it upward is negative

bent structural member or framework to strengthen a bridge or trestle

berm horizontal ledge cut between the face and top of an embankment to stabilize the slope by intercepting sliding earth

bilge curve of a ship's hull joining the side and bottom

bitt short metal or wooden post on the deck of a ship, used to secure mooring or other lines; usually in pairs

block and tackle apparatus or pulley, blocks, and ropes or cables used to haul or hoist heavy objects

boring break-bulk penetrating and piercing with a rotary tool miscellaneous goods that are packed in boxes, bales, crates, barrels, or drums; may include lumber, motor vehicles, pipe, steel, or machinery

breakwater wall built on the sea to protect shore area, harbor, anchorage, or basin from the action of water

bulkhead wall of embankment constructed in a tunnel or harbor to protect against water, gas, or fire

bulkhead limit line the line extending along the shore beyond which no solid-fill structure may extend; the bulkhead limit line and the pierhead limit line may coincide

buoy float moored in water to signal a channel danger below the water surface, or, to mark locations underwater.

caisson watertight structure with work carried on inside to block the entrance of a canal or dock, or a box with an open top fastened to the side of a ship for hull repairs

camel floating cluster of logs or a strongly constructed raft

cantilever projecting beam supported only at one end

catamaran boat with two hulls

catwalk narrow, raised platform or pathway used for passage to otherwise inaccessible areas, such as a raised walkway on a ship for use when decks are awash

caving mining procedure used when the surface is expendable, in which the ore-body is undercut and allowed to fall, breaking into small pieces that can be recovered

chamfer to cut off an edge or corner, or to cut a groove, or to flute

chock block or wedge placed under something to keep it from moving

cleat strip of wood or metal used to strengthen or support whatever it is connected to; a piece of metal with projecting arm

cofferdam temporary watertight enclosure built in water and pumped dry to expose the bottom, so construction can start

conduit any channel or pipe conducting the flow of water or other fluid

container vessel constructed or modified especially to ship containerized cargo; may or may not be self-sustaining

CONUS Continental United States

coring use of a core barrel (hollow length of tubing) to take samples from an underground formation during the drilling operation; used for core analysis

CPM critical path method

cradle framework or other raised place for supporting or restraining objects

cwt hundredweight

DA Department of the Army

deadman a buried plate, wall, or block attached at some distance from and forming an anchorage for a retaining wall; also known as an anchorage

dewater remove water from an enclosure or structure such as a river bed or a caisson

dike an embankment of earth or rock built on a levee to prevent floods

direct support role in which an engineer element is commanded by its parent unit; maintains liaison and communications with supported and parent units; may be task organized by its parent unit; provides dedicated support to a particular unit; responds to support requests from its supported unit; has work priority established by the supported unit; has spare work effort available to its parent unit; requests additional support from its parent unit; and receives logistical support from its parent unit

dolphin cluster of pilings in water used as a fender for a dock or as a mooring or guide for boats

drawhead group of rollers through which strip tubing or solid stock is drawn to form an angled section

dredge any of various machines equipped with scooping or scouring devices used to deepen harbors and waterways, and in underwater mining

dry dock a dock that can be kept dry for use during ship repairs

ELCAS elevated causeway system

end-bearing pile column with the point resting on rock or firm strata

expedient quick construction method appropriate for building temporary structures

F Fahrenheit

fairway open water of depth sufficient for navigation

fathom measure of length or depth consisting of 6 feet

fender a timber cluster of piles or a bag of ropes placed along a deck or bridge pier to prevent damage by anchoring ships or floating objects

fender pile pile driven on the outside edges of wharf structures to absorb the shock of ships movements and protect the pier structure

fetch distance wind travels to generate a wave

fiord narrow inlet of the sea between cliffs or steep slopes

fixed cranes cranes that are rigidly, usually permanently, attached to their supporting systems; examples are derricks and pedestal- and deck-mounted cranes

flange protruding rim or edge, with a collar, as on a wheel or a rope shaft; a side or lateral part

flukes parts of anchors which fasten into the ground

FM field manual

freeboard distance between the waterline and the uppermost full deck

frictional pile a column with resistance between itself and the soil into which it is driven. It transmits the load to the lateral soil

ft foot, feet

G2 Assistant Chief of Staff, G2 (Intelligence)

gantry crane frame-supported mobile crane; frame may be either rubber-tired or track supported

gate vessel shallow-draft vessel or platform equipped for use during the erection and/or repair of gates and for laying and retrieving anchors

groin barrier built out of a seashore or riverbank to protect the land from erosion and sand movements

gudgeon metal pivot at the end of an axle or shaft, around which a wheel or other device turns

gunwale upper edge of a ship's side

gusset triangular insert

hawse part of the ship where the hawseholes are located to pull cables; also the arrangements of a ship's cables, starboard and port

high watermark the highest point that water reaches during high tide

hoist to raise or haul up

hopper large funnel to hold material until ready for dispersion

hydraulic operated, moved, or effected by a fluid, especially water, under pressure

HW heavyweight team

IAW in accordance with

ISO International Standardization Organization

jetting method of driving piles with points into sand by using a jet of oil to break the surface

jetty pier or other structure projecting out over a body of water to influence the current/tide or to protect a harbor or shoreline

keel principal bottom structural element of a ship, extending along the centerline for the full length of the ship

kip 1,000-pound load

ksi kips per square inch

LACV lighter air-cushion vehicle

lb pound(s)

LCM landing craft, mechanized

LCU landing craft, utility

lighter barge used for loading and unloading

line-haul equipment for containers equipment necessary for transport of containers from piers to storage and marshaling areas

littoral shore

LOC lines of communication

long-shore littoral current in the breaker zone moving currents essentially parallel to the shore, usually generated by waves breaking at an angle to the shoreline

LOTS logistics over the shore

low watermark lowest point that is exposed during low tides

LSD landing ship, dock

LST landing ship, tank

LST Ramp a concrete ramp specifically designed for the loading and unloading of a landing ship or tank (LST)

LW lightweight team

marine railway a rail system extending below navigable waters designed to bring harbor craft out of the water for repair

mastic mixture of finely powdered rock and asphalt used for construction

maul heavy, long-handled hammer used to drive spikes and pilings

mean high water the average height of the high waters over a 19-year period, for shorter periods of observations, corrections are applied to eliminate known variations and reduce the results to the equivalent of a mean 19-year value. All high water heights are included in the average where the type of tide is either semidiurnal or mixed. Only the greater high water heights are included in the average where the type of tide is diurnal.

mean low water average height of the low waters over a 19-year period; water level is computed the same as for mean high water

MHE materials handling equipment

miter beveled edge of a piece used to fit another to form a blocking structure, such as a water lock

mole massive land-connected, solid-fill structure of earth (generally revetted), masonry, or large stone; it may serve as a breakwater or pier

msl mean sea level

NAVFAC Naval Facility

NBC nuclear, biological, chemical

NL Navy lighter

OCE Office of the Chief of Engineers

palm flat inner face of an anchor fluke

pawl pivoted tongue or sliding bolt on one part of a machine that is adapted to fall into notches or interdental spaces on another part (as a ratchet wheel) so as to permit motion in only one direction

PERT Program Evaluation and Review Technique

pier structure with a platform projecting from the shore into navigable water for mooring vessels

pierhead limit line the line beyond which no structure of any kind may extend; the pierhead limit line and the bulkhead limit line may coincide

pile construction element placed in the ground to support a load or resist a lateral force

pile bent row of timber or concrete bearing piles with a joint pile cap; forms the part of a trestle that carries the adjacent ends of timber stringers or concrete slabs

pintle vertical pivot pin

POL petroleum, oils and lubricants

psi pounds per square inch

pusher a grade for which helper engines are needed to assist road grade locomotives

quay wharf or surfaced bank where ships are loaded and unloaded

quay wall the supporting structure for a stretch of paved bank or a solid artificial landing place beside navigable water for convenience in loading or unloading ships

quoin exterior angle of a wall or a member of that angle

ratchet wheel, usually toothed, operating with a catch of a pawl so as to rotate in one direction only

recompression chamber apparatus pressurized with air to decompress a diver or treat a related diving illness after surfacing

revetment facing on a soil or rock embankment to prevent scour by water or weather

riprap foundation of revetment in water or soft ground made up of irregularly placed stones

scou sea floor erosion caused by strong tidal currents

screed straight-edged sword or metal template, fixed temporarily to a surface as a guide in concreting or plastering

scuba self-contained underwater breathing apparatus

scupper drain on or below the deck of a ship that guides water on or through the side

sextant optical instrument used in navigation for measuring angles, especially of celestial bodies

sheet pile closely placed piles of wood, steel, or concrete driven vertically into the ground to obstruct lateral movement of earth or water

ship's channel the deeper part of a harbor, river, or strait designated, marked and maintained to permit the safe passage of ships

shim thin strip of material placed between two surfaces to obtain proper fit

shoal submerged elevation rising from the bed of a shallow body of water

slack term for condition of water between ebb and rip tides

slip narrow body of water between two piers

slurry free-flowing, pumpable suspension of fine solid material in liquid

span fragment from a rock surface removed by chipping or weathering

spillway passage in or about a dam or other hydraulic structure for escape of water

sprocket tooth on the periphery of a wheel or cylinder to engage in the links of a chain

spud-type barge piers self-elevating piers consisting of barge units that are supported by several spuds (caissons or legs); these piers are suitable for either temporary or semipermanent installations

surface supplied air diving equipment where the breathing air is supplied from compressors or storage facilities on the surface

swell ocean waves that have moved away from their generating area, relatively long in length and period and regular in character

TAACOM Theater Army Area Command

TASCOM Theater Army Support Command

TC training circular

tidal prism difference between mean high-tide volume and mean low-tide volume of an estuary

TM technical manual

TO theater of operations

TOE table(s) of organization and equipment

TR technical report

TRADOC United States Army Training and Doctrine Command

TRANSCOM Transportation Command

tremie device for placing concrete underwater; consists of a large metal tube with a hopper at the top end and a valve arrangement at the submerged end

trestle series of short spans supported by a bridge tower

trestle bent transverse frame that supports the end of the stringers in adjoining spans of a trestle

truck-mounted cranes cranes mounted on chassis similar, but usually much larger, to those used in the commercial trucking industry; standard equipment usually consists of large counterweights for load balancing and outrigger floats for equalizing pressure

- turnbuckle** sleeve with a thread at one end and a swivel at the other, or with threads of opposite hands at each end, so that by turning the sleeve, connected rods or ropes will be drawn together
- wale** horizontal component of a fender system; generally placed between the vertical fenders and the pier structure and used for horizontal distribution of forces from vessels
- wildcat** pocketed and slotted wheel on a winch over which a chain passes
- warp** to move a vessel or waterborne object from one place to another by pulling on lines fastened to a buoy
- wharf** structure of open construction built parallel to the shore, used by vessels for loading and unloading
- weir** dam in a waterway over which water flows
- WF** wide flange
- winch** machine with a drum for coiling cable, used for pulling or hoisting
- windlass** machine to raise or lower anchors, consisting of a horizontal drum with gearlike projections that engage links in the anchor chain
- yawing** rotary oscillation of a vessel around a vertical axis, approximately through its center of gravity
- yd** yard

REFERENCES

These are the sources quoted or paraphrased in this publication.

Joint and Multiservice Publications

NAVFAC P-401. *Pontoon System Manual*.
STANAG 2368 MIS (Edition 1). *Guide for the Restoration of Facilities on the Lines of Communications, Ports and Other Critical Installations After Hostile Action - AAP-18*. 13 December 1985.

Army Publications

AR 310-25. *Dictionary of United States Army Terms*. 15 October 1983.
AR 310-50. *Authorized Abbreviations and Brevity Codes*. 15 November 1985.
AR 385-10. *Army Safety Program*. 23 May 1986.
AR 420-90. *Fire Protection*. 1 February 1985.
AR 611-75. *Selection, Qualification, Rating, and Disrating of Marine Divers*. 16 August 1985.
FM 5-34. *Engineer Field Data*. 14 September 1987.
FM 5-104. *General Engineering*. 12 November 1986.
FM 5-134. *Pile Construction*. 18 April 1985.
FM 5-166. *Well Drilling Operations*. 30 June 1975.
FM 5-233. *Construction Surveying*. 4 January 1985.
FM 5-277. *Bailey Bridge*. 9 May 1986.
FM 5-541. *Military Soils Engineering*. 27 May 1986.
FM 5-551. *Carpentry*. 23 February 1984.
FM 5-742. *Concrete and Masonry*. 14 March 1985.
FM 10-52. *Field Water Supply*. 27 February 1985.
FM 10-69. *Petroleum Supply Point Equipment and Operations*. 22 October 1986.
FM 20-11-1. *Military Diving (Volume 1)*. To be printed in next six months.
FM 20-11-2. *Military Diving (Volume 2)*. To be printed in next six months.
FM 25-2. *Unit Training Management*. 10 September 1984.
FM 25-3. *Training in Units*. 12 December 1984.
FM 55-15. *Transportation Reference Data*. 9 June 1986.
FM 55-50. *Army Water Transport Operations*. 7 June 1985.
FM 55-176. *Logistics Over the Shore (LOTS), Overseas Areas*.
FM 100-10. *Combat Service Support*. 18 February 1988.
FM 101-5-1. *Operational Terms and Symbols*. 21 October 1985.
FM 101-10-2. *Staff Officer's Field Manual: Organizational, Technical, and Logistical Data Extracts of Nondivisional Tables of Organization and Equipment*. 15 July 1977.

- TC 5-210. *Military Float Bridging Equipment*. 27 December 1988.
- TM 5-303. *Army Facilities Components System - Logistic Data and Bills of Material*. 1 June 1986.
- TM 5-312. *Military Fixed Bridges*. 1 December 1968.
- TM 5-315. *Fire Fighting and Rescue Procedures in Theaters of Operations*. 20 April 1971.
- TM 5-330. *Planning and Design of Roads, Airbases, and Heliports in the Theater of Operations*. 6 September 1968.
- TM 5-342. *Logging and Sawmill Operation*. 23 August 1972.
- TM 5-343. *Military Petroleum Pipeline Systems*. 20 February 1968.
- TM 5-349. *Arctic Construction*. 19 February 1962.
- TM 5-370. *Railroad Construction*. 1 September 1970.
- TM 5-545. *Geology*. 8 July 1971.
- TM 5-622. *Maintenance of Waterfront Facilities*. 1 June 1978.
- TM 5-725. *Rigging*. 3 October 1968.
- TM 5-744. *Structural Steelwork*. 10 October 1968.
- TM 5-760. *Interior Wiring*. 23 August 1968.
- Waterways Experiment Station (WES) Technical Report GL-86-21. *Evaluation and Repair of War-Damaged Port Facilities. Report 4. Concepts for Expedient War-Damaged Pier and Wharf Support Structures*. September 1988.
- Waterways Experiment Station (WES) Technical Report GL-87-12. *Evaluation and Repair of War-Damaged Port Facilities. Report 3. Concepts for Expedient War-Damaged Repair of Pier and Wharf Decking*. September 1988.
- Waterways Experiment Station (WES) Technical Report H-73-9. *Port Construction in the Theater of Operations*. September 1988.

INDEX

Illustrations and tables are shown in bold-face type.

- AASHTO. *See* responsibilities.
- aligning frame, 8-18
 - straightening a pile using an aligning frame, 8-18**
- anchorage, 5-13 thru 5-16
 - roadstead, 5-13**
- Army water terminal, C-6
- Army equipment, 10-1 thru 10-5
 - Class 60, 10-2 thru 10-4
 - Class 60 raft classes, dimensions, and propulsion requirements, 10-4**
 - M4, 10-3 thru 10-5
 - M4 raft classes, dimensions, and propulsion requirements, 10-5**
 - M4T6, 10-1 thru 10-3
 - M4T6 float section, 10-1**
 - raft classes, dimensions, and propulsion requirements, 10-2**
- balk, 10-1 thru 10-3
- batter, 8-28
- batter piles. *See* piles
- beach profile, 5-1**
- bearing piles. *See* piles.
- bending moment, 5-5
- bent, 8-11 thru 8-13
- berm, 5-1
- bilge, 10-7
- block and tackle, 8-17, 8-18
 - straightening a pile using a block and tackle, 8-17**
- bollards, 9-1
 - single- and double-bitt bollards, 9-1**
- bracing, 8-11
 - brace connected to concrete pile (external bracket-bracing method 3), A-19**
 - brace connected to concrete pile with concrete anchor (bracing method 4), A-20**
 - brace connected to steel beam pile (bracing method 2), A-18**
 - brace connected to timber or steel pipe pile (bracing method 1), A-17**
 - flexible braces, 8-20**
 - transverse bracing and cap, 8-11**
 - transverse, longitudinal, and horizontal bracing for extreme tidal range, 8-12**
- breakwaters, 5-1 thru 5-4
 - rubble-mound breakwater, 5-3**
- bulkheads, 5-5 thru 5-7
 - bulkhead using steel sheet piles and tie-rods, 7-3**
 - concrete bulkhead, 5-6**
 - steel bulkhead, 5-6**
 - timber bulkhead, 5-5**
- caissons, 11-1
- camels, 9-7
- cantilever, 5-8
- catamaran, 2-3
- catwalk, 8-21

- causeways, 10-1 thru 10-18
 - causeway, 10-3
 - causeway arrangement 1 (with pontoon wharf), 10-16
 - causeway arrangement 2 (with pontoon wharf), 10-17
 - causeway arrangement 3 (with pontoon wharf), 10-18
 - causeway using reinforced construction, 10-4
 - in-shore causeway section, 10-15
- caving, 6-6
- chocks, 8-28
 - chocks, 9-2
 - stringpiece, 8-29
- Class 60 bridge. *See* Army equipment.
- cleat, 9-2
 - plan and elevation views of an open wide-base cleat, 9-2
- conduit, 1-3
- coring, 2-4
- corner mooring posts, 9-1
 - plan and elevation views of a corner mooring post, 9-2
- CPM (Critical Path Method), 4-5
- cradle, 3-9
- cribs, 5-15, 5-16
 - rock-fill timber crib, 5-15
- damage evaluation, 4-7
- decks, 8-23 thru 8-30
- DeLong barges, 11-1 thru 11-10
 - compressor positions, 11-4
 - control panels, 11-2
 - shore connection span, 11-3
 - suitable and non-suitable soils for erecting DeLong barges, 11-6
- dike, 7-2
- diving, C-1 thru C-12
 - diving limitations, C-12
 - engineer diver deployment in the theater, C-2
 - request channels for engineer divers, C-3
- dolphins, 9-7 thru 9-9
 - timber pile cluster dolphins, 9-8
- dredging, B-1 thru B-3
- dry dock, C-7
- end-bearing pile. *See* piles.
- engineer. *See* responsibilities.
- expedient construction and repairs. *See also* repair. 12-1 thru 12-18
 - cross sections of an expedient pile cap, A-36
 - plan and elevation views of an expedient pile cap, A-35
- fendering systems
 - chocks. *See* chocks.
 - corner fender pile clusters, 9-5
 - energy to be absorbed by fenders, 11-13
 - erection of, 8-28 thru 8-30
 - fender piles, 8-28, 9-4
 - wales. *See* wales.
- fetch, 2-5
- foundation, 12-2 thru 12-7
 - concrete foundation, 12-3
 - container-floor or steel-plate foundation, 12-4
 - rubble foundation, A-1
 - steel beam foundation, 12-2
- frictional pile. *See* piles.

- graving dock, 3-9
- groins, 5-7 thru 5-10
 - cast-in-place concrete groin, 5-9**
 - rubble-mound groin, 5-10**
 - steel groins, 5-8**
 - steel sheet pile groins, 5-8**
 - timber groins, 5-7**
- harbors, 2-1 thru 2-5
 - bottom holding characteristics, 5-14**
- hopper, 4-2, B-1
- jetties, 5-10
 - quadripod armor units in jetty construction, 5-11**
- jetting, 5-7, 8-2
 - straightening a pile using a jet, 8-18**
- landing ramps, 5-16
- LCM (landing craft, mechanized), 11-5
- lighter, 4-3
- locks, 4-8
- long-shore, 6-6
- LOTS (Logistics Over the Shore), 1-4, C-5
- low watermark, C-10
- LSD (landing ship, dock), 10-9
- LST (landing ship, tank), 10-9
- M4 floating bridge. *See* Army equipment.
- M4T6 aluminum pneumatic floating bridge. *See* Army equipment.
- marine railway, 3-9
 - expedient marine railway, 12-18
 - marine lift, 12-18
 - rail nets, 6-2
- marine borers, 8-7 thru 8-10
- mastic, 8-25
- maul, 2-4
- MHE (materials handling equipment), 6-5
 - characteristics and requirements of commercial container off-loading equipment, 6-5**
- moles, 3-8, 7-1
- mooring, 5-14
 - mooring piles, 9-6**
 - ship data for mooring operations, 11-12**
 - timber platform with mooring hardware installed, 8-25**
- Navy equipment, 10-5 thru 10-18
 - 3 by 4 pontoon tug, 10-12**
 - 3 by 14 warping tug with A-frame, 10-13**
 - 4 by 15 pontoon drydock, 10-14**
 - 4 by 15 and 6 by 30 pontoon drydock data, 10-13**
 - 5 by 12 pontoon barge, 10-10**
 - 10 by 30 pontoon barge, 10-11**
 - P-series pontoons, 10-5 thru 10-18
 - P1 pontoon, 10-6**
 - P2 pontoon, 10-6**
 - P3 pontoon, 10-6**
 - P4 pontoon, 10-7**
 - P5 pontoon, 10-7**
 - size, capacity, and draft of P-series pontoons, 10-8**
 - sloping barge with ramp attached, 10-9**
 - weights and volumes of P-series pontoons, 10-8**
- Navy. *See* responsibilities.
- NL (Navy lighter), 10-5

obstacles and obstructions

- clearing, 4-7
- engineer responsibilities, 1-1, 1-4
- locating, 2-3, C-6 thru C-9

OCE (Office of the Chief of Engineers). *See* responsibilities.

pad eyes, 9-2

pad eye, 9-3

P-series pontoons. *See* Navy equipment.

PERT (Program Evaluation and Review Technique), 6-8

piers

- angled pier-and-slip system, 3-7
- finger-pier system, 3-7
- finger piers, 11-7**
- pier-and-slip system, 3-6
- spud-type barge piers, 6-5
- square-pier system, 3-5

pile bents. *See* piles.

pile clusters. *See* piles.

pile driving operations, 5-5 thru 5-7, 8-21 thru 8-23

skid-mounted pile driver, 8-23

pile wharves. *See* piles.

piles, 8-1 thru 8-31

alternate forms, A-10

batter piles, 7-1

bearing piles, 8-1 thru 8-13

bundled wood columns, A-6

container used as pile replacement (support structure), 12-7

cross-sectional area formulas for adjacent pile, A-2

cross section of 14- by 14-inch pile, 8-4

equivalent steel cross-sectional area, A-4

fender piles, 8-28, 9-4

floating template, 8-22

heavy timber piling, 8-6

interlocking piles, 8-7

joining like-diameter piles (connecting method 1), A-21

joining like-diameter piles (connecting method 2), A-22

joining like-diameter piles (connecting method 3), A-23

joining like-diameter piles (connecting method 4), A-24

joining piles at the ocean floor with concrete (connecting method 6), A-26

joining piles at the ocean floor with concrete (connecting method 7), A-27

joining steel column to base pile (connecting method 5), A-25

maximum allowable loads per pile, 8-10

pile bent common to the wharf and the approach, 8-15

pile bents, 8-11 thru 8-13

pile clusters, 9-5

pile clusters used to replace/supplement mooring hardware, 8-28

piles cut to elevation exposing steel reinforcing bars, 8-26

pile wharves, 7-1

planking, 8-6

precast-prestressed concrete sheet piles, 8-8

railroad rails and planking, 8-9

reinforced concrete pile repairs using "sea forms", A-9

reinforcing steel, 8-27

replacement timber diameter determination, A-3

sawing guides nailed across piles, 8-19

sheet piles, 5-5 thru 5-11, 7-2 thru 7-4

steel columns, A-7

- straightening, cutting, capping, and bracing steel piles, 8-21
- structural elements of pier or wharf with damaged pile, A-2
- timber grillwork, 8-30
- tongue and groove piling, 8-5
- wakefield piling, 8-6
- welded steel rail column, A-8
- wood columns, A-5
- POL (petroleum, oils and lubricants), 1-3, 3-8
- power capstan, 9-3
 - power capstan, 9-3
- pusher, 6-2
- quartermaster. *See* responsibilities.
- quays, 3-3 thru 3-5
 - quay in front of existing seawall, 6-5
- quay wall, 12-16
 - expedient quay wall repair, A-38
- recompression chamber, C-4
- releasing hooks, 9-3
 - releasing hooks, 9-3
- repair, 12-1 thru 12-18
 - alternate installation methods for repair modules (type A or B), A-32
 - assumptions for plate repair design, A-28
 - exploded isometric view (type A repair module), A-31
 - expedient quay wall repair, A-38
 - isometric view of type A module, A-29
 - optimized component placement for repair modules, A-37
 - plan and cross section (type A repair module), A-30
 - repair using steel plate reinforced by steel beams, A-33
 - steel beam mat concept repair, A-39
 - steel plate reinforced with steel beams, A-34
- responsibilities
 - AASHTO, 10-5
 - engineer, 1-1 thru 1-5, 3-2
 - Navy, 1-1, 4-5 thru 4-7
 - quartermaster, 1-2, 1-3, 3-8
 - TASCOM (Theater Army Support Command), 1-1, 3-2
 - TRANSCOM (Transportation Command), 3-2
 - transportation, 1-1 thru 1-4
- revetment, 5-7
- riprap, 5-4
- screed, 8-24
- scuba diving, C-5, C-12
- scupper, 8-25
- seawalls, 5-11
 - curved-face seawall, 5-12
 - rubble-mound seawall, 5-12
- sheet pile. *See* piles.
- shim, 12-15
- ship's channel, C-6
- shoes, 8-2
 - pointed- and flat-plate shoes, 8-2
- slack, 6-1
- slip, 3-6 thru 3-8, 6-9
- slurry, 7-4
- spud-type barge piers. *See* piers.
- stringers, 8-14, 8-22 thru 8-31
 - installing a stringpiece, 8-24

- surveys, 2-1 thru 2-4
 - bottom survey, 2-3, 2-4
 - hydrographic survey, 2-1, 2-2
 - methods, 2-1, 2-2
 - responsibility for, 2-1
- sweeping, 2-3, 4-7
- swell, 2-5
- TASCOM (Theater Army Support Command). *See* responsibilities.
- tides
 - tidal current, 2-4, 2-5
 - tidal prism, 2-5
 - tidal wave, 2-5
- TRANSCOM (Transportation Command). *See* responsibilities.
- tremie, 5-7, 5-11
- trestle, 8-14
- truss, 12-8
 - steel truss, A-14**
 - steel truss pile cap connection, A-16**
 - steel truss pile connection, A-15**
 - timber truss, A-11**
 - timber truss pile cap connection, A-12**
 - timber truss pile connection, A-13**
- tsunami, 2-5
- turnbuckle, 7-4
- wale, 8-29, 9-5
 - wales, 9-5**
- warp, 9-8
- wave-resistant walls, 5-5 thru 5-13
 - bulkheads. *See* bulkheads.
 - groins. *See* groins.
 - jetties. *See* jetties.
 - revetments. *See* revetments.
 - seawalls. *See* seawalls.
- waves, 2-5 thru 2-7
- wharf hardware, 9-1
 - bollards. *See* bollards.
 - corner mooring posts. *See* corner mooring posts.
 - cleats. *See* cleats.
 - chocks. *See* chocks.
 - pad eyes. *See* pad eyes.
 - power capstan. *See* power capstan.
 - releasing hooks. *See* releasing hooks.
- wharves
 - cold weather wharf, 8-12**
 - earth-fill wharf structures, 7-1
 - floating wharves, 10-1
 - types, 3-3 thru 3-7
 - linear feet of berthing spaces, 3-3**
 - location and layout, 6-1 thru 6-10
 - mooring lines beyond the ends of the wharf, 6-4**
 - pile wharves, 8-1 thru 8-31
 - precast concrete module, 8-16**
 - T-type marginal wharf, 11-7**
 - wharf hardware, 9-1 thru 9-4
 - wharf layout, 3-4**

FM 5-480
12 DECEMBER 1990

By Order of the Secretary of the Army:

CARL E. VUONO
General, United States Army
Chief of Staff

Official:

JOHN A . FULMER
Colonel, United States Army
Acting The Adjutant General

DISTRIBUTION:

Active Army, USAR, and ARNG: To be distributed in accordance with DA Form 12-11E, requirements for FM 5-480, Port Construction and Repair (Qty rqr block no. 4965).

PIN: 045908-000